

JVC



CD RECEIVER

KD-APD38/KD-PDR30

ENGLISH

RECEPTOR CON CD

KD-APD38/KD-PDR30

ESPAÑOL

RÉCEPTEUR CD

KD-APD38/KD-PDR30

FRANÇAIS

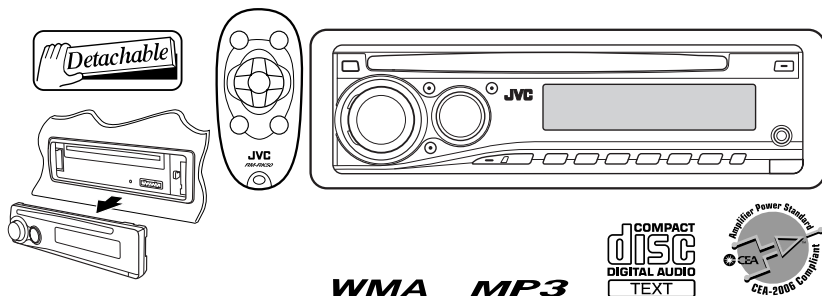

For canceling the display demonstration, see page 6.

Para cancelar la demostración en pantalla, consulte la página 6.

Pour annuler la démonstration des affichages, référez-vous à la page 6.

For installation and connections, refer to the separate manual.

Para la instalación y las conexiones, refiérase al manual separado.

Pour l'installation et les raccordements, se référer au manuel séparé.

For customer Use:

Enter below the Model No. and Serial No. which are located on the top or bottom of the cabinet. Retain this information for future reference.

Model No. _____

Serial No. _____

INSTRUCTIONS

MANUAL DE INSTRUCCIONES
MANUEL D'INSTRUCTIONS

GET0467-001A

[J]

Thank you for purchasing a JVC product.

Please read all instructions carefully before operation, to ensure your complete understanding and to obtain the best possible performance from the unit.

INFORMATION (For U.S.A.)

This equipment has been tested and found to comply with the limits for a Class B digital device, pursuant to Part 15 of the FCC Rules. These limits are designed to provide reasonable protection against harmful interference in a residential installation. This equipment generates, uses, and can radiate radio frequency energy and, if not installed and used in accordance with the instructions, may cause harmful interference to radio communications. However, there is no guarantee that interference will not occur in a particular installation. If this equipment does cause harmful interference to radio or television reception, which can be determined by turning the equipment off and on, the user is encouraged to try to correct the interference by one or more of the following measures:

- Reorient or relocate the receiving antenna.
- Increase the separation between the equipment and receiver.
- Connect the equipment into an outlet on a circuit different from that to which the receiver is connected.
- Consult the dealer or an experienced radio/TV technician for help.

Caution:

Changes or modifications not approved by JVC could void the user's authority to operate the equipment.

IMPORTANT FOR LASER PRODUCTS

1. CLASS 1 LASER PRODUCT
2. **CAUTION:** Do not open the top cover. There are no user serviceable parts inside the unit; leave all servicing to qualified service personnel.
3. **CAUTION:** (For U.S.A.) Visible and/or invisible class II laser radiation when open. Do not stare into beam.
(For Canada) Visible and/or invisible class 1M laser radiation when open. Do not view directly with optical instruments.
4. REPRODUCTION OF LABEL: CAUTION LABEL, PLACED OUTSIDE THE UNIT.

CAUTION	ATTENTION	AVISO	VARNING	注意	CAUTION
VISIBLE AND/OR INVISIBLE CLASS 1M LASER RADIATION WHEN OPEN, DO NOT VIEW DIRECTLY WITH OPTICAL INSTRUMENTS. EQR0025-1-2001 (ENG)	RAYONNEMENT LASER VISIBLE ET/OU INVISIBLE DE CLASSE 1M UNE FOIS OUVERT NE PAS REGARDER DIRECTEMENT AVEC DES INSTRUMENTS OPTIQUES. (FRA)	RADIACION LASER DE CLASE 1M VISIBLE Y/O INVISIBLE CUANDO ESTA ABIERTO, NO MIRAR DIRECTAMENTE CON INSTRUMENTAL OPTICO. (ESP)	SYNLIG OCH/ELLER OSYNLIG LASERSTRÅLNING, KLASS 1M, NÄR DENNA DEL ÄR ÖPPNAD. BETRÄKTA EJ STRÅLEN MED OPTISKA INSTRUMENT. (SWE)	ここが開口と可視 及び/または不可視 のクラス1M レーザー放射が 出ます。 光学儀器で直接 覗いてくたさい。 (JPN)	VISIBLE AND/OR INVISIBLE CLASS II LASER RADIATION WHEN OPEN, DO NOT STARE INTO BEAM. FOR CAUTION (ENG)



[European Union only]

Warning:

If you need to operate the unit while driving, be sure to look ahead carefully or you may be involved in a traffic accident.

For safety...

- Do not raise the volume level too much, as this will block outside sounds, making driving dangerous.
- Stop the car before performing any complicated operations.

Temperature inside the car...

If you have parked the car for a long time in hot or cold weather, wait until the temperature in the car becomes normal before operating the unit.

How to reset your unit

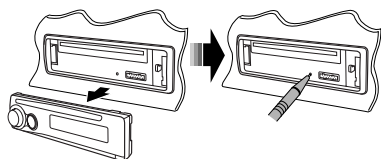

- Your preset adjustments will also be erased.

How to forcibly eject a disc

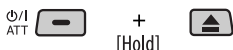

- Be careful not to drop the disc when it ejects.
- If this does not work, reset your unit.

How to use the M MODE button

If you press M MODE, the unit goes into functions mode, then the number buttons and ▲/▼ buttons work as different function buttons.

Ex.: When number button 2 works as MO (monaural) button.



To use these buttons for their original functions again after pressing M MODE, wait for 5 seconds without pressing any of these buttons until the functions mode is cleared or press M MODE again.

KD-APD38 is equipped with the steering wheel remote control function.

- See the Installation/Connection Manual (separate volume) for connection.

CONTENTS

Control panel — KD-APD38/KD-PDR30	4
Remote controller — RM-RK50	5
Getting started	6
Basic operations	6
Radio operations	7
Disc operations	8
Playing a disc in the unit	8
iPod operations	11
Sound adjustments	13
General settings — PSM	14
External component operations	16
Maintenance	16
More about this unit	17
Troubleshooting	21
Specifications	23

Detaching the control panel

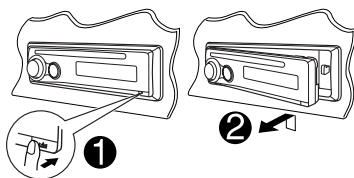

Attaching the control panel

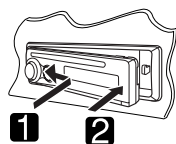

Control panel — KD-APD38 / KD-PDR30

Parts identification

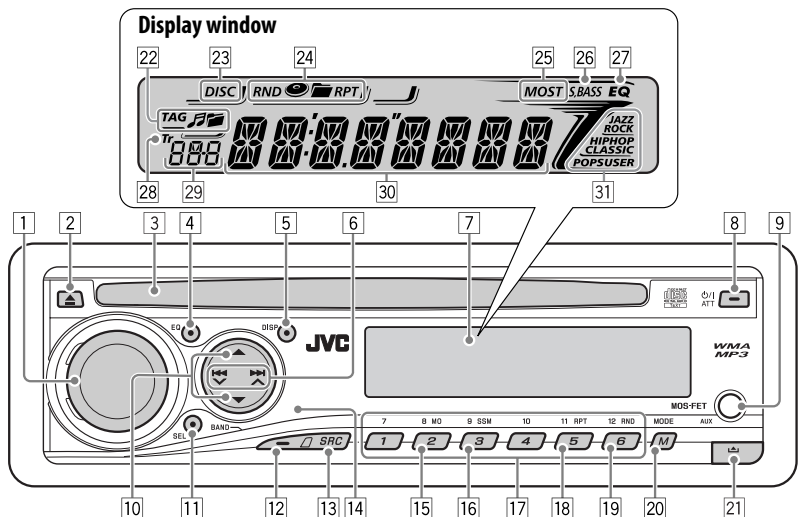

- | | |
|--|--|
| 1 Control dial | 19 RND (random) button |
| 2 ▲ (eject) button | 20 M MODE button |
| 3 Loading slot | 21 ▲ (control panel release) button |
| 4 EQ (equalizer) button | 22 Disc information indicators—
TAG (Tag information), 🎵 (track/file), 📁 (folder) |
| 5 DISP (display) button | 23 DISC indicator |
| 6 ⏮ ⏪ ⏩ ⏭ buttons | 24 Playback mode / item indicators— RND (random),
📀 (disc), 📁 (folder), RPT (repeat) |
| 7 Display window | 25 Tuner reception indicators—MO (monaural),
ST (stereo) |
| 8 ⏻ / I ATT (standby/on attenuator) button | 26 S.BASS (super bass) indicator |
| 9 AUX (auxiliary) input jack | 27 EQ (equalizer) indicator |
| 10 ▲ (up) / ▼ (down) buttons | 28 Tr (track) indicator |
| 11 SEL (select) button | 29 Source display / Time countdown indicator |
| 12 BAND button | 30 Main display |
| 13 SRC (source) button | 31 Sound mode (iEQ: intelligent equalizer)
indicators—JAZZ, ROCK, HIP HOP, CLASSIC, POPS,
USER |
| 14 Remote sensor
<i>DO NOT expose the remote sensor to strong light
(direct sunlight or artificial lighting).</i> | |
| 15 MO (monaural) button | |
| 16 SSM (Strong-station Sequential Memory) button | |
| 17 Number buttons | |
| 18 RPT (repeat) button | |

Remote controller — RM-RK50

Installing the lithium coin battery (CR2025)

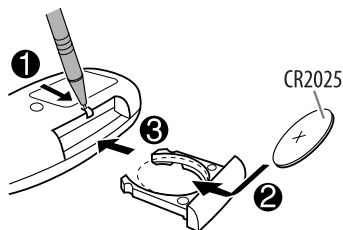

For USA-California Only:

This product contains a CR Coin Cell Lithium Battery which contains Perchlorate Material—special handling may apply.

See www.dtsc.ca.gov/hazardouswaste/perchlorate

Aim the remote controller directly at the remote sensor on the unit. Make sure there is no obstacle in between.

Warning:

- Do not install any battery other than CR2025 or its equivalent; otherwise, it may explode.
- Do not leave the remote controller in a place (such as dashboards) exposed to direct sunlight for a long time; otherwise, it may explode.
- Store the battery in a place where children cannot reach to avoid risk of accident.
- To prevent the battery from over-heating, cracking, or starting a fire:
 - Do not recharge, short, disassemble, heat the battery, or dispose of it in a fire.
 - Do not leave the battery with other metallic materials.
 - Do not poke the battery with tweezers or similar tools.
 - Wrap the battery with tape and insulate when throwing away or saving it.

Main elements and features

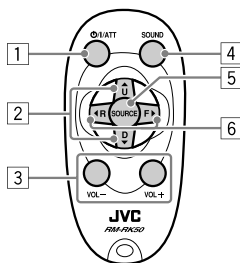

- 1** **I/ATT** (standby/on/attenuator) button
 - Turns the power on if pressed briefly or attenuates the sound when the power is on.
 - Turns the power off if pressed and held.
- 2** **▲ U** (up) / **D** (down) **▼** buttons
 - Changes the FM/AM bands with **▲ U**.
 - Changes the preset stations with **D ▼**.
 - Changes the folder of the MP3/WMA discs.
 - While listening to an Apple iPod.
 - Pauses or resumes playback with **D ▼**.
 - Enters the main menu with **▲ U**.(Now **▲ U/D ▼** / **◀ R/F ▶** work as the menu selecting buttons.)*
- 3** **VOL -** / **VOL +** buttons
 - Adjusts the volume level.
- 4** **SOUND** button
 - Selects the sound mode (iEQ: intelligent equalizer).
- 5** **SOURCE** button
 - Selects the source.
- 6** **◀ R** (reverse) / **F** (forward) **▶** buttons
 - Searches for stations if pressed briefly.
 - Fast-forwards or reverses the track if pressed and held.
 - Changes the tracks if pressed briefly.
 - While listening to an iPod (in menu selecting mode):
 - Selects an item if pressed briefly. (Then, press **D ▼** to confirm the selection.)
 - Skips 10 items at a time if pressed and held.

* **▲ U** : Returns to the previous menu.

D ▼ : Confirms the selection.

Getting started

Basic operations

1 Turn on the power.



2 **SRC**

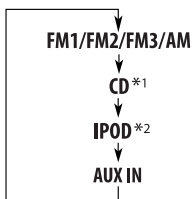

*1 You cannot select "CD" as the playback source if there is no disc in the unit.

*2 "NO IPOD" appears if iPod is not connected.

3 For FM/AM tuner



4 Adjust the volume.

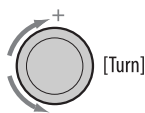

VOL 20

Volume level appears.

5 Adjust the sound as you want. (See page 13.)

Caution on volume setting:

Discs produce very little noise compared with other sources. Lower the volume before playing a disc to avoid damaging the speakers by the sudden increase of the output level.

To drop the volume in a moment (ATT)

To restore the sound, press the button again.



To turn off the power



Basic settings

- See also "General settings — PSM" on pages 14 and 15.

1 **SEL** [Hold]



1 **Canceling the display demonstrations**

Select "DEMO," then "DEMO OFF."

2 **Setting the clock**

Select "CLOCK H" (hour), then adjust the hour.
Select "CLOCK M" (minute), then adjust the minute.

3 Finish the procedure.



To check the current clock time while the power is turned off



Clock time is shown on the display for about 5 seconds. See also page 14.

Radio operations



Lights up when receiving an FM stereo broadcast with sufficient signal strength.



3 Start searching for a station.



When a station is received, searching stops.

To stop searching, press the same button again.

To tune in to a station manually

In step 3 above...



2 Select a desired station frequency.



When an FM stereo broadcast is hard to receive



Lights up when monaural mode is activated.



Reception improves, but stereo effect will be lost.

To restore the stereo effect, repeat the same procedure. "MONO OFF" appears and the MO indicator goes off.

Storing stations in memory

You can preset six stations for each band.

FM station automatic presetting—SSM (Strong-station Sequential Memory)

1 Select the FM band (FM1 – FM3) you want to store into.





"SSM" flashes, then disappears when automatic presetting is over.

Local FM stations with the strongest signals are searched and stored automatically in the FM band.

Manual presetting

Ex.: Storing FM station of 92.5 MHz into preset number 4 of the FM1 band.

- 
- 
- 

Preset number flashes for a while.

Listening to a preset station

- 
- Select the preset station (1 – 6) you want.



or



To check other information while listening to the radio

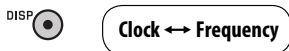

Disc operations

Playing a disc in the unit

All tracks will be played repeatedly until you change the source or eject the disc.

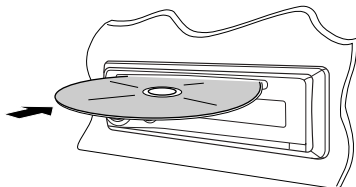

To stop play and eject the disc



- Press SRC to listen to another playback source.

To fast-forward or reverse the track



To go to the next or previous tracks



To go to the next or previous folders (only for MP3 or WMA discs)



To locate a particular track (for CD) or folder (for MP3 or WMA discs) directly

To select a number from 01 – 06:



To select a number from 07 – 12:



[Hold]

- To use direct folder access on MP3/WMA discs, it is required that folders are assigned with 2-digit numbers at the beginning of their folder names—01, 02, 03, and so on.

To select a particular track in a folder (for MP3 or WMA discs):



Other main functions

■ Skipping tracks quickly during play

- For MP3 or WMA discs, you can skip tracks within the same folder.

Ex.: To select track 32 while playing a track whose number is a single digit (1 to 9)



Each time you press the button, you can skip 10 tracks.

- After the last track, the first track will be selected and vice versa.



■ Prohibiting disc ejection

You can lock a disc in the loading slot.

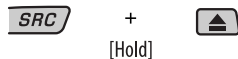

To cancel the prohibition, repeat the same procedure.

Changing the display information



While playing an audio CD or a CD Text

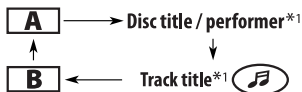

While playing an MP3 or a WMA track

- When "TAG DISP" is set to "TAG ON" (see page 15)

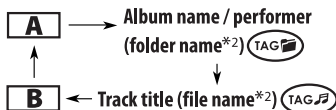

- When "TAG DISP" is set to "TAG OFF"

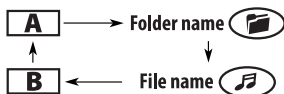

- : Clock with the current track number
 : Elapsed playing time with the current track number
 : Corresponding indicator lights up on the display

*¹ If the current disc is an audio CD, "NO NAME" appears.

*² If an MP3/WMA file does not have Tag information, folder name and file name appear. In this case, the TAG indicator will not light up.

Selecting the playback modes

You can use only one of the following playback modes at a time.

- MODE
 - Select your desired playback mode.

Repeat play

11 RPT



Mode	Plays repeatedly
TRK RPT	: The current track.
FLDR RPT*	: All tracks of the current folder.
RPT OFF	: Cancels.

Random play

12 RND



Mode	Plays at random
FLDR RND*	: All tracks of the current folder, then tracks of the next folder and so on.
DISC RND	: All tracks of the current disc.
RND OFF	: Cancels.

* Only while playing an MP3 or a WMA disc.

- : Corresponding indicator lights up on the display

iPod operations

You can play songs from an Apple iPod through this unit by connecting it with the supplied connection cable for iPod.

- Disconnecting the iPod will stop playback. Press SRC to listen to another playback source.
- For connection, see Installation/Connection Manual (separate volume).
- For details, refer also to the manual supplied with your iPod.

1 Connect an iPod.

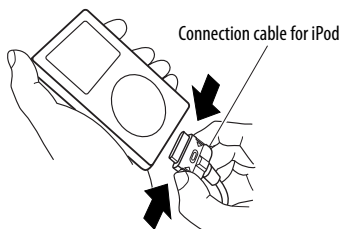

If an iPod has been connected...



Playback starts automatically from where it has been paused previously.

2 Adjust the volume.

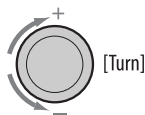

3 Adjust the sound as you want. (See page 13.)

Caution:

- Avoid using the iPod if it might hinder your safety driving.
- Make sure all important data has been backed up to avoid losing the data.

To pause playback



To resume playback, press the button again.

To fast-forward or reverse the track



To go to the next or previous tracks



Selecting a track from the menu

1 Enter the main menu.



Now the ▲/▼/◀/▶/⏪/⏩/⏮/⏭ buttons work as the menu selecting buttons*.

2 Select the desired menu.



PLAYLIST ↔ ARTISTS ↔ ALBUMS ↔
SONGS ↔ GENRES ↔ COMPOSER ↔
(back to the beginning)

3 Confirm the selection.



To move back to the previous menu, press ▲.

- If a track is selected, playback starts automatically.
- If the selected item has another layer, you will enter the layer. Repeat steps **2** and **3** until the desired track is played (see page 20).
- Holding ◀◀/▶▶/⏪/⏩ can skip 10 items at a time.

- * The menu selecting mode will be canceled:
- If no operations are done for about 5 seconds.
 - When you confirm the selection of a track.

Selecting the playback modes

1 MODE



2 Select your desired playback mode.



■ Repeat play

11 RPT



Mode Playback functions (as on iPod)

ONE RPT : Same as "Repeat One." 

ALL RPT : Same as "Repeat All."  



RPT OFF : Cancels.

■ Random play

12 RND



Mode Playback functions (as on iPod)

ALBM RND* : Same as "Shuffle Albums."  

SONG RND : Same as "Shuffle Songs." 

RND OFF : Cancels.

* Functions only if you select "ALL" in "ALBUMS" of the main "MENU."

 : Corresponding indicator lights up on the display

To check other information while listening to an iPod



Sound adjustments

You can select a preset sound mode suitable to the music genre (iEQ: intelligent equalizer).



Preset values	BAS ^{*1}	MID ^{*2}	TRE ^{*3}	S.BS ^{*4}
	Indication (For)			
USER (Flat sound)	00	00	00	OFF
ROCK (Rock or disco music)	+03	00	+02	ON
CLASSIC (Classical music)	+01	00	+03	OFF
POPS (Light music)	+02	+01	+02	OFF
HIP HOP (Funk or rap music)	+04	-02	+01	ON
JAZZ (Jazz music)	+03	00	+03	OFF

*1 : Bass; *2 : Mid-range; *3 : Treble; *4 : Super bass

Adjusting the sound

You can adjust the sound characteristics to your preference.

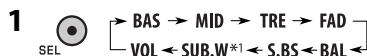

Indication, [Range]

BAS^{*2} (bass), [-06 to +06]

Adjust the bass.

MID^{*2} (mid-range), [-06 to +06]

Adjust the mid-range frequencies sound level.

TRE^{*2} (treble), [-06 to +06]

Adjust the treble.

FAD^{*3} (fader), [R06 to F06]

Adjust the front and rear speaker balance.

BAL^{*4} (balance), [L06 to R06]

Adjust the left and right speaker balance.

S.BS^{*2} (super bass), [S.BS ON or S.BS OFF], [01 to 05, initial: 03]^{*5}

Maintain the richness and fullness of the bass sound regardless of how low you set the volume.

SUB.W^{*1} (subwoofer), [00 to 08, initial: 04]

Adjust the subwoofer output level.

VOL (volume), [00 to 30 or 50^{*6}]

Adjust the volume.

*1 Displayed only when "L/O MODE" is set to "WOOFER" (see page 15).

*2 When you adjust the bass, mid-range, treble, or super bass, the adjustment you have made is stored for the currently selected sound mode (iEQ) including "USER."

*3 If you are using a two-speaker system, set the fader level to "00."

*4 This adjustment will not affect the subwoofer output.

*5 Range adjustment for super bass is adjustable only when it is set to "S.BS ON."

*6 Depending on the amplifier gain control setting. (See page 15 for details.)

General settings — PSM

You can change PSM (Preferred Setting Mode) items listed in the table that follows.

1  [Hold]

2 Select a PSM item.



3 Adjust the PSM item selected.



4 Repeat steps 2 and 3 to adjust other PSM items if necessary.

5 Finish the procedure.



Indications	Item (__: Initial)	Setting, [reference page]
DEMO Display demonstration	<ul style="list-style-type: none"> • DEMO ON • DEMO OFF 	<ul style="list-style-type: none"> : Display demonstration will be activated automatically if no operation is done for about 20 seconds, [6]. : Cancels.
CLK DISP *1 Clock display	<ul style="list-style-type: none"> • ON • OFF 	<ul style="list-style-type: none"> : Clock time is shown on the display at all times when the power is turned off. : Cancels; pressing DISP will show the clock time for about 5 seconds when the power is turned off, [6].
CLOCK H Hour adjustment	1 – 12	[Initial: 1 (1:00)], [6].
CLOCK M Minute adjustment	00 – 59	[Initial: 00 (1:00)], [6].
DIMMER Dimmer	<ul style="list-style-type: none"> • ON • OFF 	<ul style="list-style-type: none"> : Dims the display illumination. : Cancels.
SCROLL *2 Scroll	<ul style="list-style-type: none"> • ONCE • AUTO • OFF 	<ul style="list-style-type: none"> : Scrolls the track information once. : Repeats scrolling (at 5-second intervals). : Cancels. • Pressing DISP for more than one second can scroll the display regardless of the setting.

*1 If the power supply is not interrupted by turning off the ignition key of your car, it is recommended to select "OFF" to save the car's battery.

*2 Some characters or symbols will not be shown correctly (or will be blanked) on the display.

Indications	Item (__: Initial)	Setting, [reference page]
L/O MODE Line output mode	<ul style="list-style-type: none"> • REAR • WOOFER 	<ul style="list-style-type: none"> : Select if both the LINE OUT terminals are used for connecting the speakers (through an external amplifier). : Select if the REAR LINE OUT terminals are used for connecting a subwoofer (through an external amplifier).
WOOFER * ³ Subwoofer cutoff frequency	<ul style="list-style-type: none"> • LOW • MID • HIGH 	<ul style="list-style-type: none"> : Frequencies lower than 90 Hz are sent to the subwoofer. : Frequencies lower than 135 Hz are sent to the subwoofer. : Frequencies lower than 180 Hz are sent to the subwoofer.
AUX ADJ Auxiliary input level adjustment	<ul style="list-style-type: none"> • A.ADJ 00 — A.ADJ 05 	: Adjust the auxiliary input level to avoid the sudden increase of the output level when changing the source from external component connected to the AUX input jack on the control panel.
TAG DISP Tag display	<ul style="list-style-type: none"> • TAG ON • TAG OFF 	<ul style="list-style-type: none"> : Shows the Tag information while playing MP3/WMA tracks, [10]. : Cancels.
AMP GAIN Amplifier gain control	<ul style="list-style-type: none"> • LOW PWR • HIGH PWR 	<ul style="list-style-type: none"> : VOL 00 – VOL 30. (Select this if the maximum power of the speaker is less than 50 W to prevent damaging the speaker.) : VOL 00 – VOL 50.
AREA Tuner channel interval	<ul style="list-style-type: none"> • AREA US • AREA EU • AREA SA 	<ul style="list-style-type: none"> : When using in North/Central/South America. AM/FM intervals are set to 10 kHz/200 kHz. : When using in any other areas except North/Central/South America. AM/FM intervals are set to 9 kHz/50 kHz (100 kHz during auto search). : When using in South American countries. AM/FM intervals are set to 10 kHz/100 kHz.
IF BAND Intermediate frequency band	<ul style="list-style-type: none"> • AUTO • WIDE 	<ul style="list-style-type: none"> : Increases the tuner selectivity to reduce interference noises between close stations. (Stereo effect may be lost.) : Subject to interference noises from adjacent stations, but sound quality will not be degraded and the stereo effect will remain.

*³ Displayed only when "L/O MODE" is set to "WOOFER."

External component operations

You can connect an external component to the AUX (auxiliary) input jack on the control panel.

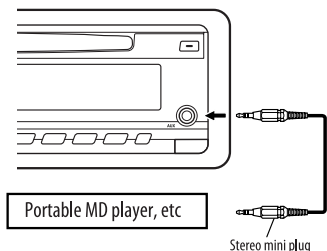

2 Turn on the connected component and start playing the source.

3 Adjust the volume.

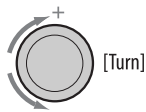

4 Adjust the sound as you want. (See page 13.)

To check other information while listening to an external component



Clock ↔ AUX IN

Maintenance

How to clean the connectors

Frequent detachment will deteriorate the connectors. To minimize this possibility, periodically wipe the connectors with a cotton swab or cloth moistened with alcohol, being careful not to damage the connectors.

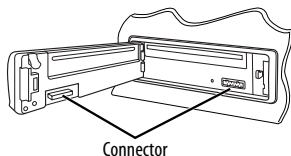

Moisture condensation

Moisture may condense on the lens inside the unit in the following cases:

- After starting the heater in the car.
- If it becomes very humid inside the car.

Should this occur, the unit may malfunction. In this case, eject the disc and leave the unit turned on for a few hours until the moisture evaporates.

How to handle discs

When removing a disc from its case, press down the center holder of the case and lift the disc out, holding it by the edges.

Center holder



- Always hold the disc by the edges. Do not touch its recording surface.

When storing a disc into its case, gently insert the disc around the center holder (with the printed surface facing up).

- Make sure to store discs into the cases after use.

To keep discs clean

A dirty disc may not play correctly.

If a disc does become dirty, wipe it with a soft cloth in a straight line from center to edge.



- Do not use any solvent (for example, conventional record cleaner, spray, thinner, benzene, etc.) to clean discs.

To play new discs

New discs may have some rough spots around the inner and outer edges. If such a disc is used, this unit may reject the disc.

To remove these rough spots, rub the edges with a pencil or ball-point pen, etc.



Do not use the following discs:

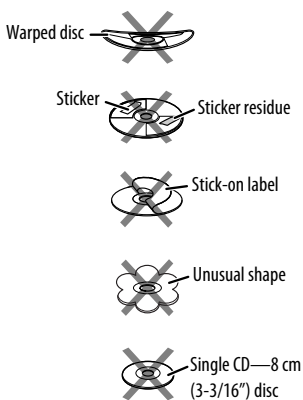

More about this unit

Basic operations

Turning on the power

- By pressing SRC on the unit, you can also turn on the power. If the source is ready, playback also starts.

Turning off the power

- If you turn off the power while listening to a track, playback starts from where playback it has been stopped previously, next time you turn on the power.

General

- If you change the source while listening to a disc or an iPod, playback stops. Next time you select "CD" or "IPOD" as the playback source, playback starts from where it has been stopped/paused previously.
- After ejecting a disc or disconnecting an iPod, "NO DISC" or "NO IPOD" appears and you cannot operate some of the buttons. Insert another disc, reconnect an iPod, or press SRC to select another playback source.

Tuner operations

Storing stations in memory

- During SSM search...
 - All previously stored stations are erased and stations are stored newly.
 - Received stations are preset in No. 1 (lowest frequency) to No. 6 (highest frequency).
 - When SSM is over, the station stored in No. 1 will be automatically tuned in.
- When storing a station manually, the previously preset station is erased when a new station is stored in the same preset number.

Continued on the next page

Disc operations

Caution for DualDisc playback

- The Non-DVD side of a “DualDisc” does not comply with the “Compact Disc Digital Audio” standard. Therefore, the use of Non-DVD side of a DualDisc on this product may not be recommended.

General

- This unit has been designed to reproduce CDs/CD Texts, and CD-Rs (Recordable)/CD-RWs (Rewritable) in audio CD (CD-DA), MP3 and WMA formats.
- When a disc is inserted upside down, “PLEASE” and “EJECT” appear alternately on the display. Press ▲ to eject the disc.
- MP3 and WMA “tracks” (words “file” and “track” are used interchangeably) are recorded in “folders.”
- While fast-forwarding or reversing on an MP3 or WMA disc, you can only hear intermittent sounds.

Playing a CD-R or CD-RW

- Use only “finalized” CD-Rs or CD-RWs.
- This unit can play back only files of the same type which are first detected if a disc includes both audio CD (CD-DA) files and MP3/WMA files.
- This unit can play back multi-session discs; however, unclosed sessions will be skipped while playing.
- Some CD-Rs or CD-RWs may not play back on this unit because of their disc characteristics, or for the following reasons:
 - Discs are dirty or scratched.
 - Moisture condensation occurs on the lens inside the unit.
 - The pickup lens inside the unit is dirty.
 - CD-R/CD-RW on which the files are written with “Packet Write” method.
 - There are improper recording conditions (missing data, etc.) or media conditions (stained, scratched, warped, etc.).
- CD-RWs may require a longer readout time since the reflectance of CD-RWs is lower than that of regular CDs.

- Do not use the following CD-Rs or CD-RWs:
 - Discs with stickers, labels, or a protective seal stuck to the surface.
 - Discs on which labels can be directly printed by an ink jet printer.
 Using these discs under high temperatures or high humidities may cause malfunctions or damage to the unit.

Playing an MP3/WMA disc

- This unit can play back MP3/WMA files with the extension code <.mp3> or <.wma> (regardless of the letter case—upper/lower).
- This unit can show the names of albums, artists (performer), and Tag (Version 1.0, 1.1, 2.2, 2.3, or 2.4) for MP3 files and for WMA files.
- This unit can display only one-byte characters. No other characters can be correctly displayed.
- This unit can play back MP3/WMA files meeting the conditions below:
 - Bit rate: 8 kbps — 320 kbps
 - Sampling frequency:
 - 48 kHz, 44.1 kHz, 32 kHz (for MPEG-1)
 - 24 kHz, 22.05 kHz, 16 kHz (for MPEG-2)
 - Disc format: ISO 9660 Level 1/Level 2, Romeo, Joliet, Windows long file name
- The maximum number of characters for file/folder names vary among the disc format used (includes 4 extension characters—<.mp3> or <.wma>).
 - ISO 9660 Level 1: up to 12 characters
 - ISO 9660 Level 2: up to 31 characters
 - Romeo: up to 128 characters
 - Joliet: up to 64 characters
 - Windows long file name: up to 128 characters
- This unit can recognize a total of 512 files, of 200 folders, and of 8 hierarchies.
- This unit can play back files recorded in VBR (variable bit rate).

Files recorded in VBR have a discrepancy in elapsed time display, and do not show the actual elapsed time. Especially, after performing the search function, this difference becomes noticeable.

- This unit cannot play back the following files:
 - MP3 files encoded with MP3i and MP3 PRO format.
 - MP3 files encoded in an inappropriate format.
 - MP3 files encoded with Layer 1/2.
 - WMA files encoded with lossless, professional, and voice format.
 - WMA files which are not based upon Windows Media® Audio.
 - WMA files copy-protected with DRM.
 - Files which have the data such as AIFF, ATRAC3, etc.
- The search function works but search speed is not constant.

Ejecting a disc

- If the ejected disc is not removed within 15 seconds, the disc is automatically inserted again into the loading slot to protect it from dust. Playback starts automatically.

iPod operations

Controllable iPod	Software version
iPod with dock connector (3rd Generation)	2.3 or later
iPod with Click Wheel (4th Generation)	3.1 or later
iPod mini	1.4 or later
iPod photo	1.2 or later
iPod nano	1.0 or later
iPod with Video (5th Generation)	1.0 or later

- If your iPod software version is older than those mentioned above, you may not be able to control the iPod properly. Update your iPod to the latest software version before using it with this unit.
 - You can check the software version of your iPod from “About” in the “Setting” menu of the iPod.
 - For details about updating your iPod, visit <<http://www.apple.com>>.

- When you turn on this unit, the iPod is charged through this unit.
- While the iPod is connected, all operations from the iPod are disabled. Perform all operations from this unit.
- While connecting an iPod with Video:
 - No video shows on the iPod’s display or the external monitor (only the audio part is available).
 - It is not possible to browse video files on the “Video” menu. (If you connect the iPod during playback or pausing of a video file, resuming playback will not work.)
- iPod shuffle is not controllable.
- You can control the iPod from this unit when “JVC” or “√” appears on the iPod display.
- The songs order displayed on the selecting menu of this unit may differ from the iPod.
- If playback is stopped, select a track from the selecting menu or press ▼.
- The text information may not be displayed correctly.
 - Some characters such as accented letters cannot be shown correctly on the display.
 - Depends on the condition of communication between the iPod and the unit.
- If the text information includes more than 8 characters, it scrolls on the display. This unit can display up to 40 characters.

General settings—PSM

- If you change the “AMP GAIN” setting from “HIGH PWR” to “LOW PWR” while the volume level is set higher than “VOL 30,” the unit automatically changes the volume level to “VOL 30.”

Hierarchical structure of file searching when an iPod is connected

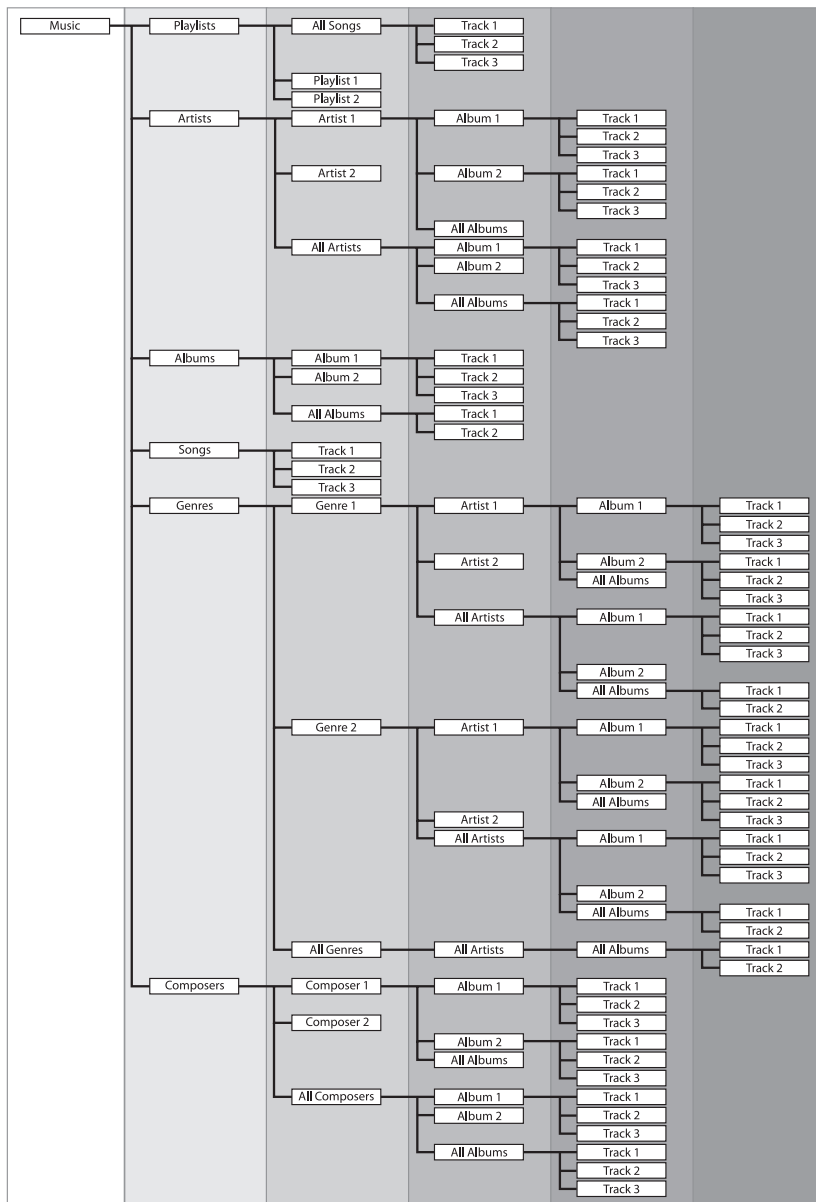

Troubleshooting

What appears to be trouble is not always serious. Check the following points before calling a service center.

	Symptoms	Remedies/Causes
General	<ul style="list-style-type: none"> • Sound cannot be heard from the speakers. 	<ul style="list-style-type: none"> • Adjust the volume to the optimum level. • Check the cords and connections.
	<ul style="list-style-type: none"> • The unit does not work at all. 	Reset the unit (see page 3).
FM/AM	<ul style="list-style-type: none"> • SSM automatic presetting does not work. 	Store stations manually.
	<ul style="list-style-type: none"> • Static noise while listening to the radio. 	Connect the antenna firmly.
Disc playback	<ul style="list-style-type: none"> • Disc cannot be played back. 	Insert the disc correctly.
	<ul style="list-style-type: none"> • CD-R/CD-RW cannot be played back. • Tracks on the CD-R/CD-RW cannot be skipped. 	<ul style="list-style-type: none"> • Insert a finalized CD-R/CD-RW. • Finalize the CD-R/CD-RW with the component which you used for recording.
	<ul style="list-style-type: none"> • Disc can neither be played back nor ejected. 	<ul style="list-style-type: none"> • Unlock the disc (see page 9). • Eject the disc forcibly (see page 3).
	<ul style="list-style-type: none"> • Disc sound is sometimes interrupted. 	<ul style="list-style-type: none"> • Stop playback while driving on rough roads. • Change the disc. • Check the cords and connections.
	<ul style="list-style-type: none"> • "NO DISC" appears on the display. 	Insert a playable disc into the loading slot.
MP3/WMA playback	<ul style="list-style-type: none"> • Disc cannot be played back. 	<ul style="list-style-type: none"> • Use a disc with MP3/WMA tracks recorded in the format compliant with ISO 9660 Level 1, Level 2, Romeo, or Joliet. • Add the extension code <.mp3> or <.wma> to the file names.
	<ul style="list-style-type: none"> • Noise is generated. 	Skip to another track or change the disc. (Do not add the extension code <.mp3> or <.wma> to non-MP3 or WMA tracks.)
	<ul style="list-style-type: none"> • A longer readout time is required ("CHECK" keeps flashing on the display). 	Do not use too many hierarchies and folders.

Continued on the next page

	Symptoms	Remedies/Causes
MP3/WMA playback	• Tracks do not play back in the order you have intended them to play.	Playback order is determined when the files are recorded.
	• Elapsed playing time is not correct.	This sometimes occurs during play. This is caused by how the tracks are recorded on the disc.
	• "PLEASE" and "EJECT" appear alternately on the display.	Insert a disc that contains MP3/WMA tracks.
	• Correct characters are not displayed (e.g. album name).	This unit can only display letters (upper case), numbers, and a limited number of symbols.
iPod playback	• The iPod does not turn on or does not work.	<ul style="list-style-type: none"> • Check the connecting cable and its connection. • Update the firmware version. • Charge the battery.
	• The sound is distorted.	Deactivate the equalizer either on the unit or the iPod.
	• "NO IPOD" appears on the display.	<ul style="list-style-type: none"> • Check the connecting cable and its connection. • Charge the battery
	• Playback stops.	The headphones are disconnected during playback. Turn off the unit's power and turn it on again.
	• No sound can be heard when connecting an iPod nano.	<ul style="list-style-type: none"> • Disconnect the headphones from the iPod nano. • Update the firmware version of the iPod nano.
	• "NO FILES" appears on the display.	No tracks are stored. Import tracks to the iPod.
	• "RESET 1" – "RESET 7" appears on the display.	Reconnect the iPod.
	• "RESET 8" appears on the display.	Check the connecting cable and its connection
• The iPod's controls do not work after disconnecting from this unit.	Reset the iPod.	

- Microsoft and Windows Media are either registered trademarks or trademarks of Microsoft Corporation in the United States and/or other countries.
- iPod is a trademark of Apple Computer, Inc., registered in the U.S. and other countries.

Specifications

AUDIO AMPLIFIER SECTION

Power Output:

20 W RMS × 4 Channels at 4 Ω
and ≤ 1% THD+N

Signal-to-Noise Ratio:

80 dBA (reference: 1 W into 4 Ω)



Load Impedance: 4 Ω (4 Ω to 8 Ω allowance)

Tone Control Range:

Bass/Mid-range/Treble: ±12 dB at 60 Hz/1 kHz/
7.5 kHz

Frequency Response: 40 Hz to 20 000 Hz

Line-Out Level/Impedance:

KD-APD38: 4.0 V/20 kΩ load (full scale)

KD-PDR30: 2.5 V/20 kΩ load (full scale)

Subwoofer-Out Level/Impedance:

KD-APD38: 4.0 V/20 kΩ load (full scale)

KD-PDR30: 2.5 V/20 kΩ load (full scale)

Output Impedance: 1 kΩ

Other Terminal:

AUX (auxiliary) input jack, iPod jack, Steering wheel
remote input (only for KD-APD38)

TUNER SECTION

Frequency Range:

FM: 87.5 MHz to 107.9 MHz

(with channel interval set to 100 kHz or 200 kHz)

87.5 MHz to 108.0 MHz

(with channel interval set to 50 kHz)

AM: 530 kHz to 1 710 kHz

(with channel interval set to 10 kHz)

531 kHz to 1 602 kHz

(with channel interval set to 9 kHz)

FM Tuner

Usable Sensitivity: 11.3 dBf (1.0 μV/75 Ω)

50 dB Quietening Sensitivity: 16.3 dBf (1.8 μV/75 Ω)

Alternate Channel

Selectivity (400 kHz): 65 dB

Frequency Response: 40 Hz to 15 000 Hz

Stereo Separation: 35 dB

AM Tuner

Sensitivity/Selectivity: 20 μV/35 dB

CD PLAYER SECTION

Type:	Compact disc player
Signal Detection System:	Non-contact optical pickup (semiconductor laser)
Number of Channels:	2 channels (stereo)
Frequency Response:	5 Hz to 20 000 Hz
Dynamic Range:	96 dB
Signal-to-Noise Ratio:	98 dB
Wow and Flutter:	Less than measurable limit
MP3 Decoding Format: (MPEG1/2 Audio Layer 3)	
Max. Bit Rate:	320 kbps
WMA (Windows Media® Audio) Decoding Format:	
Max. Bit Rate:	192 kbps

GENERAL

Power Requirement:	
Operating Voltage:	DC 14.4 V (11 V to 16 V allowance)
Grounding System:	Negative ground
Allowable Operating Temperature:	0°C to +40°C (32°F to 104°F)
Dimensions (W × H × D): (approx.)	
Installation Size:	182 mm × 52 mm × 150 mm (7-3/16" × 2-1/16" × 5-15/16")
Panel Size:	187 mm × 58 mm × 13 mm (7-3/8" × 2-5/16" × 9/16")
Mass:	1.3 kg (2.9 lbs) (excluding accessories)

Design and specifications are subject to change without notice.

If a kit is necessary for your car, consult your telephone directory for the nearest car audio speciality shop.



Having TROUBLE with operation?

Please reset your unit

Refer to page of How to reset your unit

Still having trouble??

USA ONLY

Call 1-800-252-5722

<http://www.jvc.com>

We can help you!

JVC

 EN, SP, FR

© 2006 Victor Company of Japan, Limited

1206DTSMDTJEIN

JVC KD-APD38/KD-PDR30

Installation/Connection Manual

Manual de instalación/conexión

Manuel d'installation/raccordement

GET0467-002A
[J]

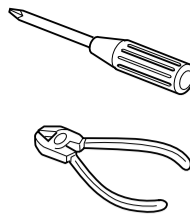

1206DTSMDTJEIN
EN, SP, FR

© 2006 Victor Company of Japan, Limited

ENGLISH

This unit is designed to operate on **12 V DC, NEGATIVE ground electrical systems**. If your vehicle does not have this system, a voltage inverter is required, which can be purchased at JVC car audio dealers.

WARNINGS

To prevent short circuits, we recommend that you disconnect the battery's negative terminal and make all electrical connections before installing the unit.

- **Be sure to ground this unit to the car's chassis again after installation.**

Notes:

- Replace the fuse with one of the specified rating. If the fuse blows frequently, consult your JVC car audio dealer.
- It is recommended to connect to the speakers with maximum power of more than 50 W (both at the rear and at the front, with an impedance of **4 Ω to 8 Ω**). If the maximum power is less than 50 W, change "AMP GAIN" setting to prevent the speakers from being damaged (see page 15 of the INSTRUCTIONS).
- To prevent short-circuit, cover the terminals of the UNUSED leads with insulating tape.
- The heat sink becomes very hot after use. Be careful not to touch it when removing this unit.

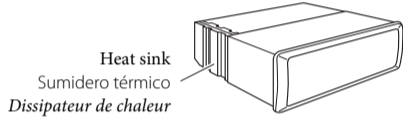

ESPAÑOL

Esta unidad está diseñada para funcionar con **12 V de CC, con sistemas eléctricos de masa NEGATIVA**. Si su vehículo no posee este sistema, será necesario un inversor de tensión, que puede ser adquirido en los concesionarios de JVC de equipos de audio para automóviles.

ADVERTENCIAS

Para evitar cortocircuitos, recomendamos que desconecte el terminal negativo de la batería y que efectúe todas las conexiones eléctricas antes de instalar la unidad.

- **Asegúrese de volver a conectar a masa esta unidad al chasis del automóvil después de la instalación.**

Notas:

- Reemplace el fusible por uno con la corriente especificada. Si el fusible se quemase frecuentemente consulte con su concesionario de JVC de equipos de audio para automóviles.
- Se recomienda conectar los altavoces con una potencia máxima de más de 50 W (tanto atrás como adelante, con una impedancia de **4 Ω a 8 Ω**). Si la potencia máxima es de menos de 50 W, cambie "AMP GAIN" para evitar daños en los altavoces (consulte la página 15 del MANUAL DE INSTRUCCIONES).
- Para evitar cortocircuitos, cubra los cables NO UTILIZADOS con cinta aislante.
- El sumidero térmico estará muy caliente después del uso. Asegúrese de no tocarlo al desmontar esta unidad.

FRANÇAIS

Cet appareil est conçu pour fonctionner sur des sources de **courant continu de 12 V à masse NEGATIVE**. Si votre véhicule n'offre pas ce type d'alimentation, il vous faut un convertisseur de tension, que vous pouvez acheter chez un revendeur d'autoradios JVC.

AVERTISSEMENTS

Pour éviter tout court-circuit, nous vous recommandons de débrancher la borne négative de la batterie et d'effectuer tous les raccordements électriques avant d'installer l'appareil.

- **Assurez-vous de raccorder de nouveau la mise à la masse de cet appareil au châssis de la voiture après l'installation.**

Remarques:

- Remplacer le fusible par un de la valeur précisée. Si le fusible saute souvent, consulter votre revendeur d'autoradios JVC.
- Il est recommandé de connecter des enceintes avec une puissance de plus de 50 W (les enceintes arrière et les enceintes avant, avec une impédance comprise entre **4 Ω et 8 Ω**). Si la puissance maximum est inférieure à 50 W, changez "AMP GAIN" pour éviter d'endommager vos enceintes (voir page 15 du MANUAL D'INSTRUCTIONS).
- Pour éviter les court-circuits, couvrir les bornes des fils qui ne sont PAS UTILISÉS avec de la bande isolante.
- Le dissipateur de chaleur devient très chaud après usage. Faire attention de ne pas le toucher en retirant cet appareil.

PRECAUTIONS on power supply and speaker connections:

- **DO NOT connect the speaker leads of the power cord to the car battery; otherwise, the unit will be seriously damaged.**
- BEFORE connecting the speaker leads of the power cord to the speakers, check the speaker wiring in your car.

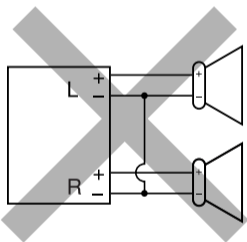

PRECAUCIONES sobre las conexiones de la fuente de alimentación y de los altavoces:

- **NO conecte los conductores de altavoz del cable de alimentación a la batería de automóvil, pues podrían producirse graves daños en la unidad.**
- ANTES de conectar a los altavoces los conductores de altavoz del cable de alimentación, verifique el conexionado de altavoz de su automóvil.

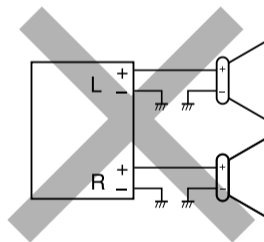

PRECAUTIONS sur l'alimentation et la connexion des enceintes:

- **NE CONNECTEZ PAS les fils d'enceintes du cordon d'alimentation à la batterie; sinon, l'appareil serait sérieusement endommagé.**
- AVANT de connecter les fils d'enceintes du cordon d'alimentation aux enceintes, vérifiez le câblage des enceintes de votre voiture.

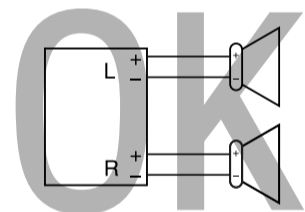

Parts list for installation and connection

The following parts are provided for this unit. If any item is missing, consult your JVC car audio dealer immediately.

Lista de piezas para instalación y conexión

Con esta unidad se suministran las siguientes piezas. Si hay algún elemento faltante, consulte inmediatamente con su concesionario de JVC de equipos de audio para automóviles.

Liste des pièces pour l'installation et raccordement

Les pièces suivantes sont fournies avec cet appareil. Si quelque chose manquait, consultez votre revendeur autoradio JVC immédiatement.

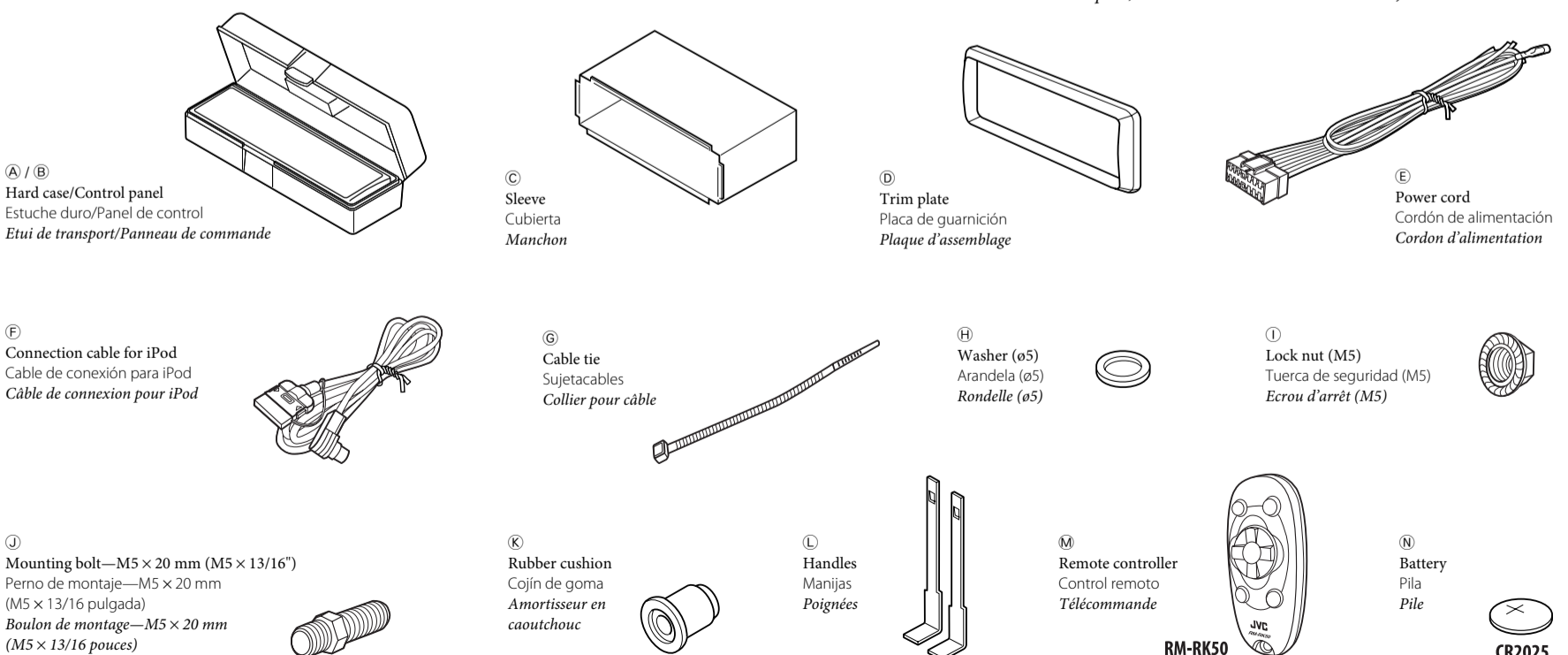

INSTALLATION (IN-DASH MOUNTING)

The following illustration shows a typical installation. If you have any questions or require information regarding installation kits, consult your JVC car audio dealer or a company supplying kits.

- If you are not sure how to install this unit correctly, have it installed by a qualified technician.

INSTALACION (MONTAJE EN EL TABLERO DE INSTRUMENTOS)

La siguiente ilustración muestra una instalación típica. Si tiene alguna pregunta o necesita información acerca de las herramientas para instalación, consulte con su concesionario de JVC de equipos de audio para automóviles o a una compañía que suministra tales herramientas.

- Si usted no está seguro de cómo instalar correctamente la unidad, hágala instalar por un técnico cualificado.

INSTALLATION (MONTAGE DANS LE TABLEAU DE BORD)

L'illustration suivante est un exemple d'installation typique. Si vous avez des questions ou avez besoin d'information sur des kits d'installation, consulter votre revendeur d'autoradios JVC ou une compagnie d'approvisionnement.

- Si l'on n'est pas sûr de pouvoir installer correctement cet appareil, le faire installer par un technicien qualifié.

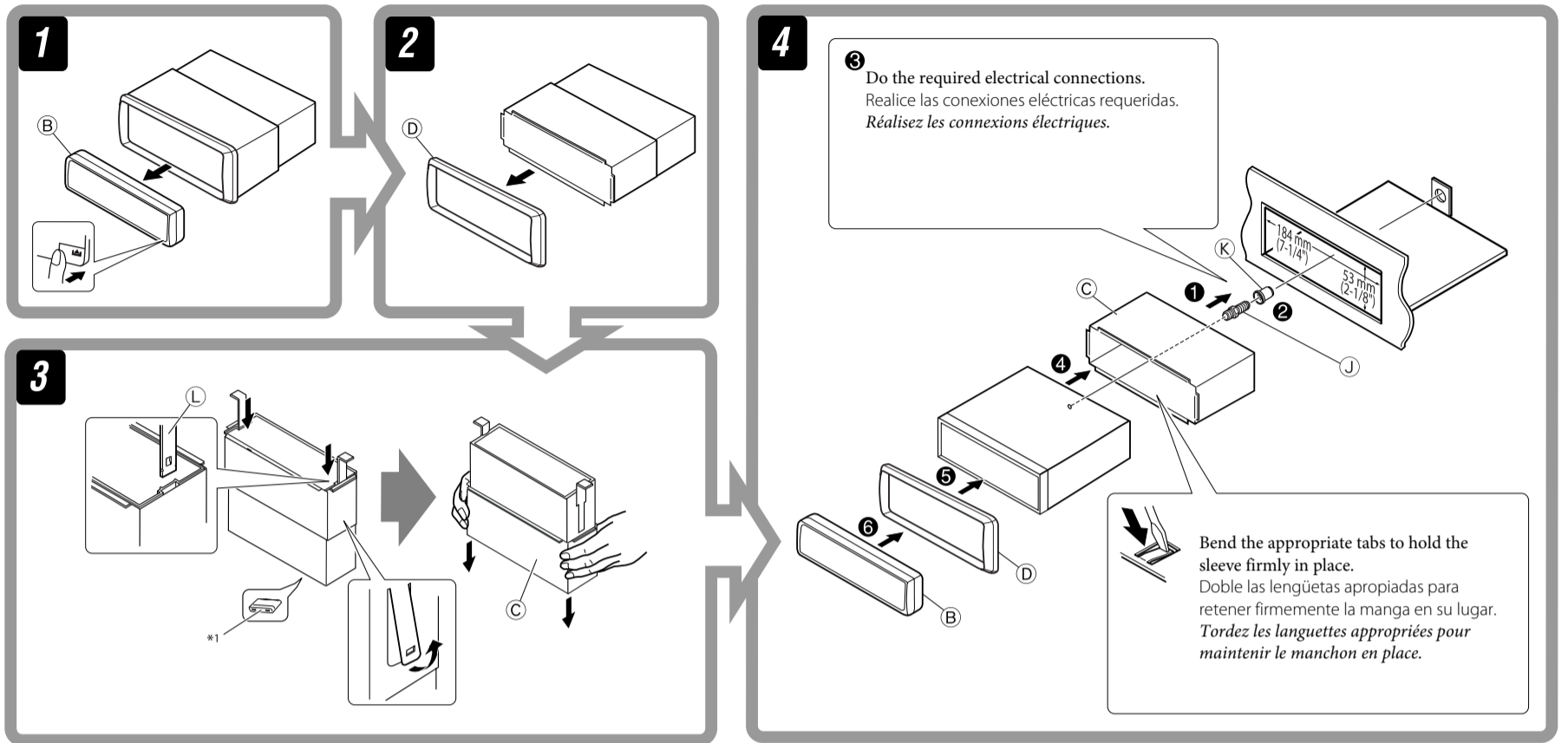

Removing the unit

Before removing the unit, release the rear section.

Extracción de la unidad

Antes de extraer la unidad, libere la sección trasera.

Retrait de l'appareil

Avant de retirer l'appareil, libérez la section arrière.

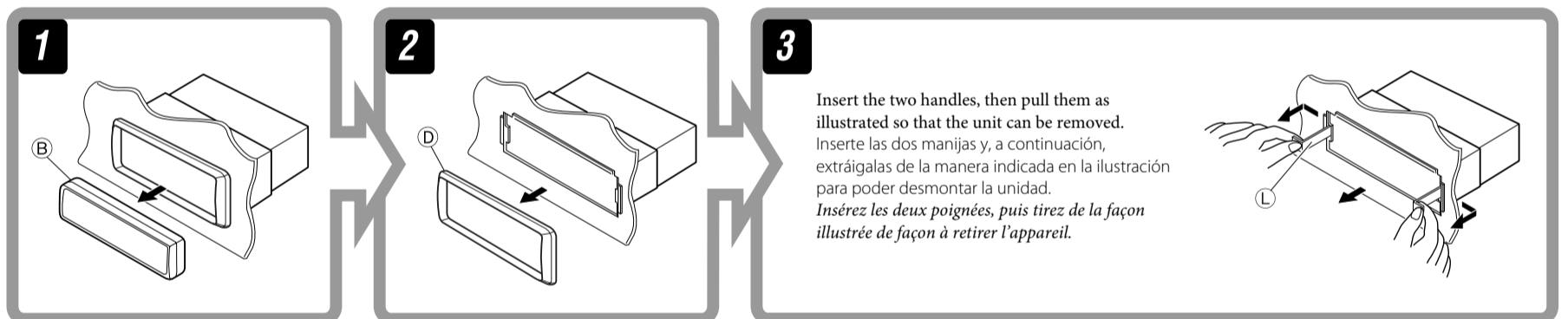

When using the optional stay / Cuando emplea un soporte opcional / Lors de l'utilisation du hauban en option

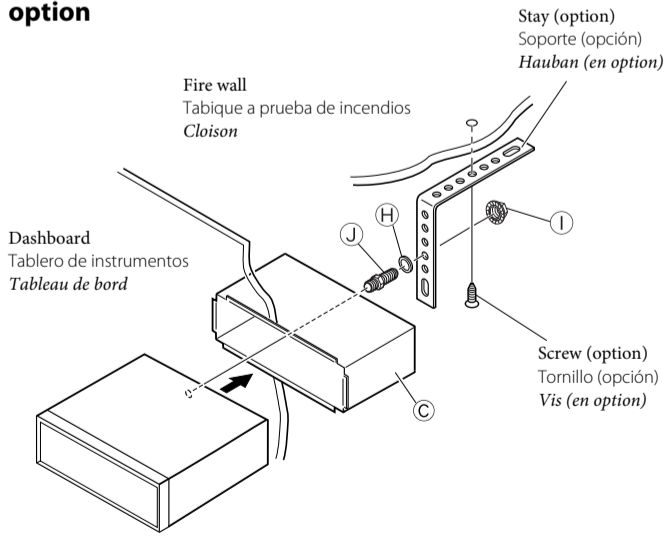

Install the unit at an angle of less than 30°.
Instale la unidad a un ángulo de menos de 30°.
Installez l'appareil avec un angle de moins de 30°.

When installing the unit without using the sleeve / Instalación de la unidad sin utilizar la cubierta / Lors de l'installation de l'appareil sans utiliser de manchon

In a Toyota car for example, first remove the car radio and install the unit in its place.
En un automóvil Toyota, por ejemplo, en primer lugar desmonte el autorradio e instale la unidad en su lugar.
Dans une voiture Toyota, par exemple, retirez d'abord l'autoradio et installez l'appareil à sa place.

Flat type screws—M5 × 8 mm (M5 × 3/8")*²
Tornillos tipo plano—M5 × 8 mm (M5 × 3/8 pulgada)*²
Vis à tête plate—M5 × 8 mm (M5 × 3/8 pouces)*²

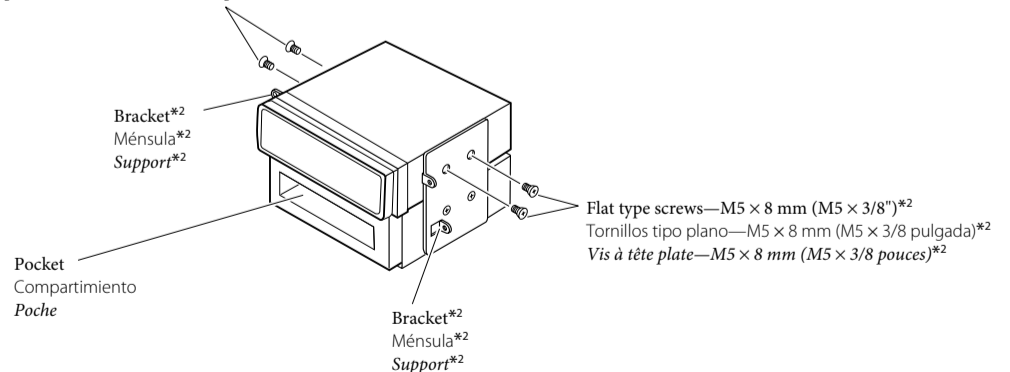

- Note** : When installing the unit on the mounting bracket, make sure to use the 8 mm (3/8")-long screws. If longer screws are used, they could damage the unit.
- Nota** : Cuando instala la unidad en la ménsula de montaje, asegúrese de utilizar los tornillos de 8 mm (3/8 pulgada) de longitud. Si se utilizan tornillos más largos, éstos pueden dañar la unidad.
- Remarque** : Lors de l'installation de l'appareil sur le support de montage, s'assurer d'utiliser des vis d'une longueur de 8 mm (3/8 pouces). Si des vis plus longues sont utilisées, elles peuvent endommager l'appareil.

*¹ When you stand the unit, be careful not to damage the fuse on the rear.

*² Not supplied for this unit.

*¹ Al poner la unidad vertical, tenga cuidado de no dañar el fusible provisto en la parte posterior.

*² No suministrado con esta unidad.

*¹ Lorsque vous mettez l'appareil à la verticale, faire attention de ne pas endommager le fusible situé sur l'arrière.

*² Non fourni avec cet appareil.

ELECTRICAL CONNECTIONS

CONEXIONES ELECTRICAS

RACCORDEMENTS ELECTRIQUES

A Typical connections / Conexiones típicas / Raccordements typiques

Before connecting: Check the wiring in the vehicle carefully. Incorrect connection may cause serious damage to this unit. The leads of the power cord and those of the connector from the car body may be different in color.

- 1 Connect the colored leads of the power cord in the order specified in the illustration below.
- 2 Connect the antenna cord.
- 3 Finally connect the wiring harness to the unit.

Antes de la conexión: Verifique atentamente el conexionado del vehículo. Una conexión incorrecta podría producir daños graves en la unidad. Los cordones del cable de alimentación y los del conector procedentes de la carrocería del automóvil podrían ser de diferentes en color.

- 1 Conecte los conductores de color del cable de alimentación en el orden especificado en la ilustración de abajo.
- 2 Conecte el cable de antena.
- 3 Por último, conecte el cable de alimentación a la unidad.

Avant de commencer la connexion: Vérifiez attentivement le câblage du véhicule. Une connexion incorrecte peut endommager sérieusement l'appareil. Le fil du cordon d'alimentation et ceux des connecteurs du châssis de la voiture peuvent être différents en couleur.

- 1 Connectez les fils colorés du cordon d'alimentation dans l'ordre spécifié sur l'illustration ci-dessous.
- 2 Connectez le cordon d'antenne.
- 3 Finalement, connectez le faisceau de fils à l'appareil.

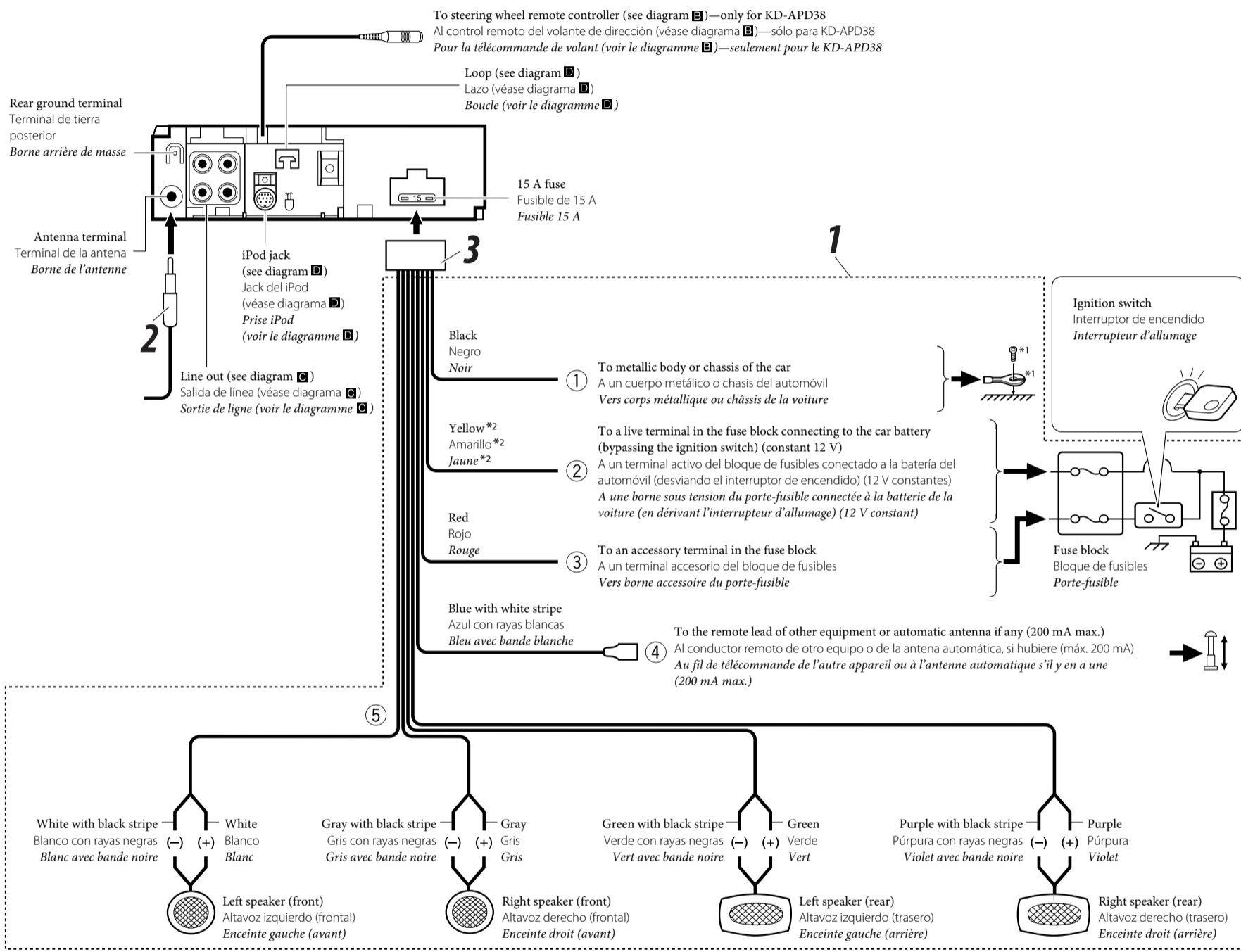

B Connecting to the steering wheel remote controller (only for KD-APD38) / Conexión al control remoto del volante de dirección (sólo para KD-APD38) / Connexion de la télécommande de volant (seulement pour le KD-APD38)

If your car is equipped with the steering wheel remote controller, you can operate this unit using the controller. For connection, an exclusive remote adapter (not supplied) which matches your car is required. For details, consult the same car audio dealer as where the unit is purchased.

Si su automóvil está equipado con control remoto en el volante de dirección, podrá controlar este receptor utilizando el control remoto. Para la conexión, se requiere un adaptador remoto exclusivo (no suministrado) que sea adecuado para su automóvil. Para los detalles, consulte con el concesionario car audio donde compró el receptor.

Si votre voiture est équipée d'une télécommande de volant, vous pouvez commander cet autoradio en utilisant cette télécommande. Pour la connexion, vous avez besoin d'un adaptateur de télécommande spécialisé (non fourni) correspondant à votre voiture. Pour en savoir plus, consultez le revendeur autoradio où vous avez acheté votre autoradio.

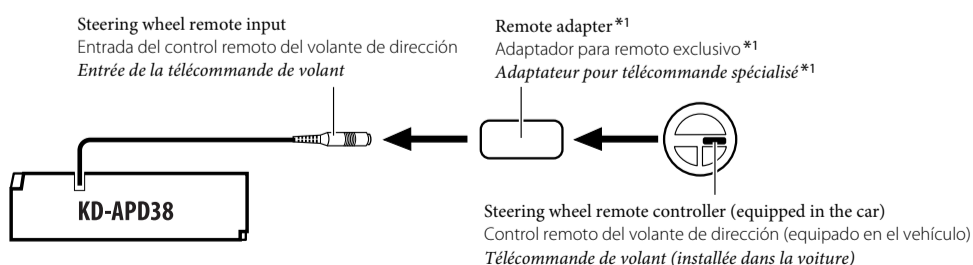

*1 Not supplied for this unit.

*2 Before checking the operation of this unit prior to installation, this lead must be connected, otherwise power cannot be turned on.

*1 No suministrado con esta unidad.

*2 Antes de comprobar el funcionamiento de esta unidad previa a de la instalación, es necesario conectar este cable, de lo contrario no se podrá conectar la alimentación.

*1 Non fourni avec cet appareil.

*2 Pour vérifier le fonctionnement de cet appareil avant installation, ce fil doit être raccordé, sinon l'appareil ne peut pas être mis sous tension.

C Connecting the external amplifiers and/or subwoofer / Conexión de los amplificadores y/o subwoofer externos / Connexion d'amplificateurs extérieurs et/ou d'un caisson de grave

You can connect amplifiers to upgrade your car stereo system.

- Connect the remote lead (blue with white stripe) to the remote lead of the other equipment so that it can be controlled through this unit.
- **Disconnect the speakers from this unit, connect them to the amplifier. Leave the speaker leads of this unit unused.**
- For KD-APD38: The line output level of this unit is kept high to maintain the hi-fi sounds reproduced from this unit.

When connecting an external amplifier to this unit, turn down the gain control on the external amplifier to obtain the best performance from this unit.

Usted podrá conectar amplificadores para mejorar el sistema estéreo de su automóvil.

- Conecte el conductor remoto (azul con rayas blancas) al conductor remoto del otro equipo para poderlo controlar a través de esta unidad.
- **Desconecte los altavoces de esta unidad y conéctelos al amplificador. Los cables de los altavoces de esta unidad quedan sin usar.**
- Para KD-APD38: El nivel de salida de línea de esta unidad permanece alto para que corresponda con los sonidos de alta fidelidad reproducidos por esta unidad. Cuando conecte un amplificador externo a esta unidad, disminuya el control de ganancia del amplificador externo para obtener un óptimo rendimiento de esta unidad.

Vous pouvez connecter des amplificateurs pour améliorer votre système autoradio.

- Connectez le fil de commande à distance (bleu avec bande blanche) au fil de commande à distance de l'autre appareil de façon qu'il puisse être commandé via cet appareil.
- **Déconnectez les enceintes de cet appareil et connectez-les à l'amplificateur. Laissez les fils d'enceintes de cet appareil inutilisés.**
- Pour le KD-APD38: Le niveau de sortie de ligne de cet appareil est maintenu à un niveau élevé pour maintenir une qualité Hi-Fi pour les sons reproduits par cet appareil. Lors de la connexion d'un amplificateur extérieur à cet appareil, diminuez le réglage du gain sur l'amplificateur extérieur pour obtenir les meilleures performances de cet appareil.

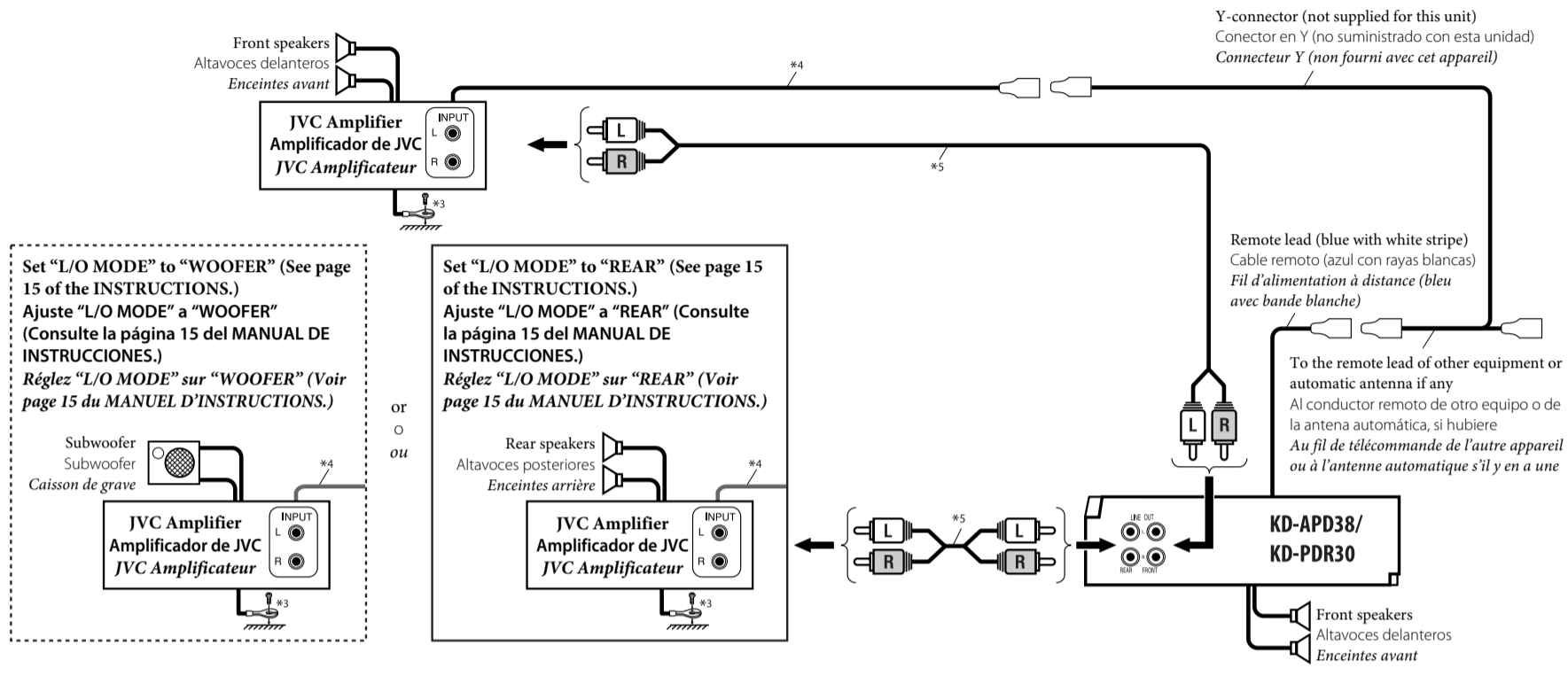

D Connecting an Apple iPod / Conexión del Apple iPod / Connexion d'un iPod Apple

You can connect an iPod to this unit using the supplied connection cable for iPod.

- 1 Insert the supplied cable tie across the loop.
- 2 Press in the head of the connection cable for iPod until you hear a clicking sound.
- 3 Fasten the connection cable using the cable tie to firmly hold the connection cable in place.

Puede conectar el iPod a esta unidad mediante el cable de conexión de iPod suministrado.

- 1 Inserte el sujetacables suministrado a través del lazo.
- 2 Presione la cabeza del cable de conexión para iPod hasta escuchar un chasquido.
- 3 Sujete el cable de conexión utilizando el sujetacables de manera que quede firmemente retenido en su lugar.

Vous pouvez connecter un iPod à cet appareil en utilisant le câble de connexion du iPod fourni.

- 1 Insérez le collier pour câble fourni dans la boucle.
- 2 Faites pression sur la tête du câble de connexion pour iPod jusqu'à ce que vous entendiez un dé clic.
- 3 Fixez le câble de connexion en utilisant le collier pour câble pour le maintenir solidement le câble de connexion en place.

iPod is a trademark of Apple Computer, Inc., registered in the U.S. and other countries.
iPod es una marca comercial de Apple Computer, Inc., registrada en los EE.UU. y otros países.
iPod est une marque de commerce d'Apple Computer, Inc., enregistrée aux États-Unis et dans les autres pays.

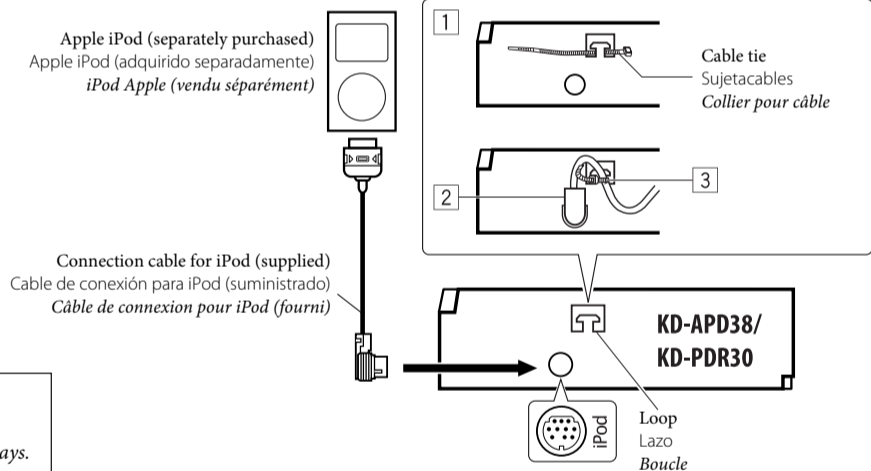

*3 Firmly attach the ground wire to the metallic body or to the chassis of the car—to the place uncoated with paint (if coated with paint, remove the paint before attaching the wire). Failure to do so may cause damage to the unit.

*4 Remote lead

*5 Signal cord (not supplied for this unit).

*3 Fije firmemente el cable de tierra a la carrocería metálica o al chasis—a un lugar no cubierto con pintura (si está cubierto con pintura, quítela antes de fijar el cable). De lo contrario, se podrían producir daños en la unidad.

*4 Cable remoto

*5 Cable de señal (no suministrado con esta unidad).

*3 Attachez solidement le fil de mise à la masse au châssis métallique de la voiture—à un endroit qui n'est pas recouvert de peinture (s'il est recouvert de peinture, enlevez d'abord la peinture avant d'attacher le fil). L'appareil peut être endommagé si cela n'est pas fait correctement.

*4 Fil d'alimentation à distance

*5 Cordon de signal (non fourni avec cet appareil).

TROUBLESHOOTING

• The fuse blows.

- * Are the red and black leads connected correctly?

• Power cannot be turned on.

- * Is the yellow lead connected?

• No sound from the speakers.

- * Is the speaker output lead short-circuited?

• Sound is distorted.

- * Is the speaker output lead grounded?
- * Are the "—" terminals of L and R speakers grounded in common?

• Noise interfere with sounds.

- * Is the rear ground terminal connected to the car's chassis using shorter and thicker cords?

• This unit becomes hot.

- * Is the speaker output lead grounded?
- * Are the "—" terminals of L and R speakers grounded in common?

• This unit does not work at all.

- * Have you reset your unit?

LOCALIZACION DE AVERIAS

• El fusible se quema.

- * ¿Están los conductores rojo y negro correctamente conectados?

• No es posible conectar la alimentación.

- * ¿Está el cable amarillo conectado?

• No sale sonido de los altavoces.

- * ¿Está el cable de salida del altavoz cortocircuitado?

• El sonido presenta distorsión.

- * ¿Está el cable de salida del altavoz conectado a masa?
- * ¿Están los terminales "—" de los altavoces L y R conectados a una masa común?

• Perturbación de ruido.

- * ¿El terminal de tierra trasero está conectado al chasis del automóvil utilizando los cordones más corto y más grueso?

• Esta unidad se calienta.

- * ¿Está el cable de salida del altavoz conectado a masa?
- * ¿Están los terminales "—" de los altavoces L y R conectados a una masa común?

• Esta unidad no funciona en absoluto.

- * ¿Reinicializó la unidad?

EN CAS DE DIFFICULTES

• Le fusible saute.

- * Les fils rouge et noir sont-ils raccordés correctement?

• L'appareil ne peut pas être mise sous tension.

- * Le fil jaune est-elle raccordée?

• Pas de son des enceintes.

- * Le fil de sortie d'enceinte est-il court-circuité?

• Le son est déformé.

- * Le fil de sortie d'enceinte est-il à la masse?
- * Les bornes "—" des enceintes gauche et droit sont-elles mises ensemble à la masse?

• Interférence avec les sons.

- * La prise arrière de mise à la terre est-elle connectée au châssis de la voiture avec un cordon court et épais?

• Cet appareil devient chaud.

- * Le fil de sortie d'enceinte est-il à la masse?
- * Les bornes "—" des enceintes gauche et droit sont-elles mises ensemble à la masse?

• Cet appareil ne fonctionne pas du tout.

- * Avez-vous réinitialisé votre appareil?

JVC

ENGLISH

FRANÇAIS

CD RECEIVER
RÉCEPTEUR CD

KD-PDR31

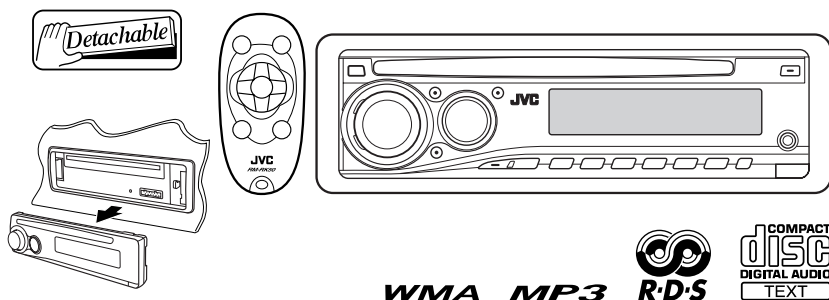

For canceling the display demonstration, see page 6.

Pour annuler la démonstration des affichages, référez-vous à la page 6.

For installation and connections, refer to the separate manual.

Pour l'installation et les raccordements, se référer au manuel séparé.

INSTRUCTIONS

MANUEL D'INSTRUCTIONS

GET0469-003A
[EX/EU]

Thank you for purchasing a JVC product.

Please read all instructions carefully before operation, to ensure your complete understanding and to obtain the best possible performance from the unit.

IMPORTANT FOR LASER PRODUCTS

1. CLASS 1 LASER PRODUCT
2. **CAUTION:** Do not open the top cover. There are no user serviceable parts inside the unit; leave all servicing to qualified service personnel.
3. **CAUTION:** Visible and/or invisible class 1M laser radiation when open. Do not view directly with optical instruments.
4. REPRODUCTION OF LABEL: CAUTION LABEL, PLACED OUTSIDE THE UNIT.

CAUTION VISIBLE AND/OR INVISIBLE CLASS 1M LASER RADIATION WHEN OPEN, DO NOT VIEW DIRECTLY WITH OPTICAL INSTRUMENTS IEC60825-1:2001 (ENG)	ATTENTION RAYONNEMENT LASER VISIBLE ET/OU INVISIBLE DE CLASSE 1M UNE FOIS OUVERT. NE PAS REGARDER DIRECTEMENT AVEC DES INSTRUMENTS OPTIQUES. (FRN)	AVISO RADIACIÓN LASER DE CLASE 1M VISIBLE Y/O INVISIBLE CUANDO ESTA ABIERTO, NO MIRAR DIRECTAMENTE CON INSTRUMENTAL OPTICO. (ESP)	VARNING SYNLIG OCH/ELLER OSYNLIG LASERSTRÅLNING, KLASS 1M, NÅR DENNA DEL ÄR ÖPPNAD. BETRÄKTA EJ STRÅLEN MED OPTISKA INSTRUMENT. (SWE)	注意 ここを開くと有害 なびやな光線が のクラス1M レーザー放射が 出ます。 光学鏡などで直接 見ないでください。 (JPN)	CAUTION VISIBLE AND/OR INVISIBLE CLASS 1 LASER RADIATION WHEN OPEN. DO NOT STARE INTO BEAM. FDA 21 CFR (ENG)
---	---	--	--	--	---

Warning:

If you need to operate the unit while driving, be sure to look ahead carefully or you may be involved in a traffic accident.



This symbol is only valid in the European Union.

Information for Users on Disposal of Old Equipment

This symbol indicates that the product with this symbol should not be disposed as general household waste at its end-of-life. If you wish to dispose of this product, please do so in accordance with applicable national legislation or other rules in your country and municipality. By disposing of this product correctly, you will help to conserve natural resources and will help prevent potential negative effects on the environment and human health.

How to reset your unit

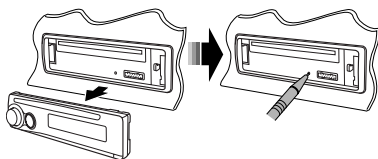

- Your preset adjustments will also be erased.

How to forcibly eject a disc



- Be careful not to drop the disc when it ejects.
- If this does not work, reset your unit.

How to use the M MODE button

If you press M MODE, the unit goes into functions mode, then the number buttons and ▲/▼ buttons work as different function buttons.

Ex.: When number button 2 works as MO (monaural) button.



To use these buttons for their original functions again after pressing M MODE, wait for 5 seconds without pressing any of these buttons until the functions mode is cleared or press M MODE again.

Detaching the control panel

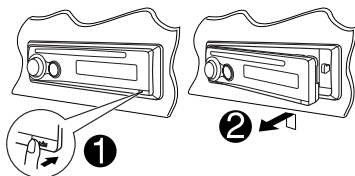

Attaching the control panel

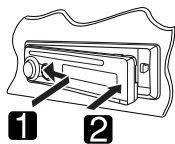

Caution on volume setting:

Discs produce very little noise compared with other sources. Lower the volume before playing a disc to avoid damaging the speakers by the sudden increase of the output level.

CONTENTS

Control panel	4
Remote controller — RM-RK50	5
Getting started	6
Basic operations	6
Radio operations	7
FM RDS operations	8
Searching for your favorite FM RDS programme	8
Disc operations	10
Playing a disc in the unit	10
iPod operations	12
Sound adjustments	14
General settings — PSM	15
External component operations	18
More about this unit	18
Maintenance	22
Troubleshooting	23
Specifications	25

Note: Only for [EX] model users in UK and European countries

For security reasons, a numbered ID card is provided with this unit, and the same ID number is imprinted on the unit's chassis. Keep the card in a safe place, as it will help the authorities to identify your unit if stolen.

For safety...

- Do not raise the volume level too much, as this will block outside sounds, making driving dangerous.
- Stop the car before performing any complicated operations.

Temperature inside the car...

If you have parked the car for a long time in hot or cold weather, wait until the temperature in the car becomes normal before operating the unit.

Control panel

Parts identification

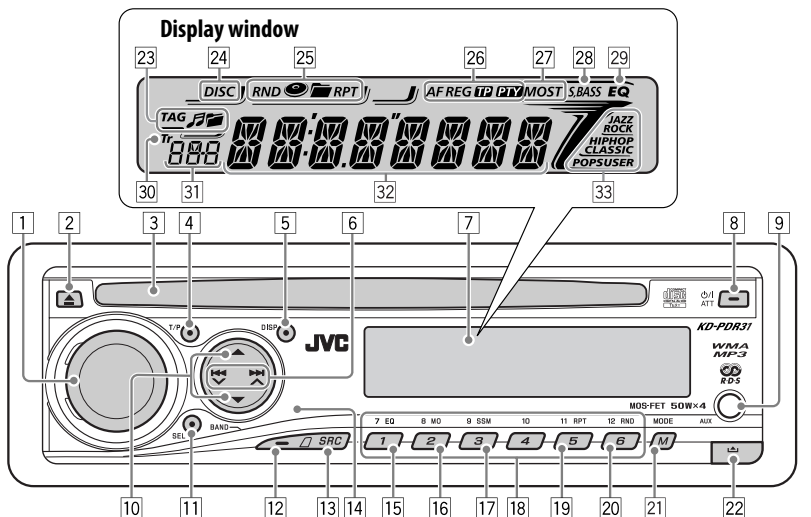

- | | | | |
|----|---|----|---|
| 1 | Control dial | 20 | RND (random) button |
| 2 | ▲ (eject) button | 21 | M MODE button |
| 3 | Loading slot | 22 | ▲ (control panel release) button |
| 4 | T/P (traffic programme/programme type) button | 23 | Disc information indicators—
TAG (Tag information), 🎵 (track/file), 📁 (folder) |
| 5 | DISP (display) button | 24 | DISC indicator |
| 6 | ◀◀ ▶▶ / ▶▶▶ ▶▶▶ buttons | 25 | Playback mode / item indicators—RND (random),
📁 (disc), 📁 (folder), RPT (repeat) |
| 7 | Display window | 26 | RDS indicators—AF, REG, TP, PTY |
| 8 | ⏻ / ATT (standby/on attenuator) button | 27 | Tuner reception indicators—MO (monaural),
ST (stereo) |
| 9 | AUX (auxiliary) input jack | 28 | S.BASS (super bass) indicator |
| 10 | ▲ (up) / ▼ (down) buttons | 29 | EQ (equalizer) indicator |
| 11 | SEL (select) button | 30 | Tr (track) indicator |
| 12 | BAND button | 31 | Source display / Time countdown indicator |
| 13 | SRC (source) button | 32 | Main display |
| 14 | Remote sensor
<i>DO NOT expose the remote sensor to strong light
(direct sunlight or artificial lighting).</i> | 33 | Sound mode (iEQ: intelligent equalizer)
indicators—JAZZ, ROCK, HIP HOP, CLASSIC, POPS,
USER |
| 15 | EQ (equalizer) button | | |
| 16 | MO (monaural) button | | |
| 17 | SSM (Strong-station Sequential Memory) button | | |
| 18 | Number buttons | | |
| 19 | RPT (repeat) button | | |

Installing the lithium coin battery (CR2025)

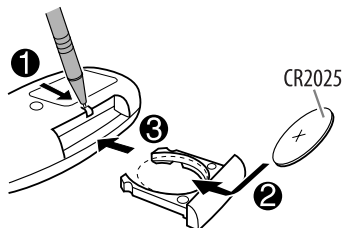

Aim the remote controller directly at the remote sensor on the unit. Make sure there is no obstacle in between.

Warning:

- Do not install any battery other than CR2025 or its equivalent; otherwise, it may explode.
- Do not leave the remote controller in a place (such as dashboards) exposed to direct sunlight for a long time; otherwise, it may explode.
- Store the battery in a place where children cannot reach to avoid risk of accident.
- To prevent the battery from over-heating, cracking, or starting a fire:
 - Do not recharge, short, disassemble, heat the battery, or dispose of it in a fire.
 - Do not leave the battery with other metallic materials.
 - Do not poke the battery with tweezers or similar tools.
 - Wrap the battery with tape and insulate when throwing away or saving it.

This unit is equipped with the steering wheel remote control function.

- See the Installation/Connection Manual (separate volume) for connection.

Main elements and features

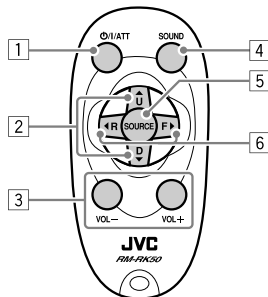

- ⏻ / I/ATT (standby/on/attenuator) button

 - Turns the power on if pressed briefly or attenuates the sound when the power is on.
 - Turns the power off if pressed and held.
- ▲ U (up) / D (down) ▼ buttons

 - Changes the FM/AM bands with ▲ U.
 - Changes the preset stations with D ▼.
 - Changes the folder of the MP3/WMA discs.
 - While listening to an Apple iPod:
 - Pauses or resumes playback with D ▼.
 - Enters the main menu with ▲ U.
 (Now ▲ U/D ▼/◀ R/F ▶ work as the menu selecting buttons.)*
- VOL – / VOL + buttons

 - Adjusts the volume level.
- SOUND button

 - Selects the sound mode (iEQ: intelligent equalizer).
- SOURCE button

 - Selects the source.
- ◀ R (reverse) / F (forward) ▶ buttons

 - Searches for stations if pressed briefly.
 - Fast-forwards or reverses the track if pressed and held.
 - Changes the tracks if pressed briefly.
 - While listening to an iPod (in menu selecting mode):
 - Selects an item if pressed briefly. (Then, press D ▼ to confirm the selection.)
 - Skips 10 items at a time if pressed and held.

* ▲ U : Returns to the previous menu.

D ▼ : Confirms the selection.

Getting started

Basic operations

1 Turn on the power.



2

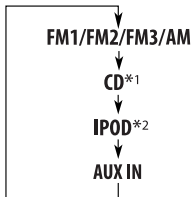

*1 You cannot select "CD" as the playback source if there is no disc in the unit.

*2 "NO IPOD" appears if iPod is not connected.

3 For FM/AM tuner



4 Adjust the volume.

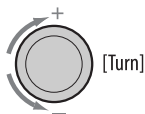

VOL 20

Volume level appears.

5 Adjust the sound as you want. (See pages 14 and 15.)

To drop the volume in a moment (ATT) To restore the sound, press the button again.	
To turn off the power	[Hold]

Basic settings

- See also "General settings — PSM" on pages 15 – 17.

1 [Hold]

2 → [Turn]

1 **Canceling the display demonstrations**

Select "DEMO," then "DEMO OFF."

2 **Setting the clock**

Select "CLOCK H" (hour), then adjust the hour. Select "CLOCK M" (minute), then adjust the minute.

Select "24H/12H," then "24H" (hour) or "12H" (hour).

3 Finish the procedure.



To check the current clock time while the power is turned off



Clock time is shown on the display for about 5 seconds. See also page 16.

Radio operations



Lights up when receiving an FM stereo broadcast with sufficient signal strength.



3 Start searching for a station.



When a station is received, searching stops.
To stop searching, press the same button again.

To tune in to a station manually

In step 3 above...

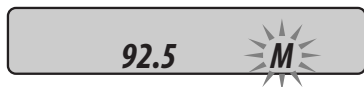

2 Select a desired station frequency.



When an FM stereo broadcast is hard to receive



Lights up when monaural mode is activated.



Reception improves, but stereo effect will be lost.

To restore the stereo effect, repeat the same procedure. "MONO OFF" appears and the MO indicator goes off.

Storing stations in memory

You can preset six stations for each band.

FM station automatic presetting—SSM (Strong-station Sequential Memory)

1 Select the FM band (FM1 – FM3) you want to store into.

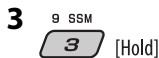



"SSM" flashes, then disappears when automatic presetting is over.

Local FM stations with the strongest signals are searched and stored automatically in the FM band.

Manual presetting

Ex.: Storing FM station of 92.5 MHz into preset number 4 of the FM1 band.

- 
- 
- 

Preset number flashes for a while.

Listening to a preset station

- 
- Select the preset station (1 – 6) you want.



or



To check the current clock time while listening to an FM (non-RDS) or AM station

- For FM RDS stations, see page 10.



FM RDS operations

What you can do with RDS

RDS (Radio Data System) allows FM stations to send an additional signal along with their regular programme signals.

By receiving the RDS data, this unit can do the following:

- Programme Type (PTY) Search (see the following)
- TA (Traffic Announcement) and PTY Standby Receptions (see pages 9 and 16)
- Tracing the same programme automatically —Network-Tracking Reception (see page 10)
- Programme Search (see pages 10 and 16)

Searching for your favorite FM RDS programme

You can tune in to a station broadcasting your favorite programme by searching for a PTY code.

- To store your favorite programme types, see page 9.

- 

The last selected PTY code appears.
- Select one of your favorite programme types.



or

Select one of the PTY codes (see page 10).

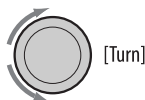

3 Start searching for your favorite programme.



If there is a station broadcasting a programme of the same PTY code as you have selected, that station is tuned in.

Storing your favorite programme types

You can store six favorite programme types.

Preset programme types in the number buttons (1 to 6):

1	2	3	4	5	6
POP M	ROCK M	EASY M	CLASSICS	AFFAIRS	VARIED

- 1 Select a PTY code (see steps 1 to 3 on pages 8 and 9).
- 2 Select the preset number (1 – 6) you want to store into.



[Hold]



Ex.: When "ROCK M" is selected

- 3 Repeat steps 1 and 2 to store other PTY codes into other preset numbers.
- 4 Finish the procedure.



[Hold]

Using the standby receptions

TA Standby Reception

TA Standby Reception allows the unit to switch temporarily to Traffic Announcement (TA) from any source other than AM.

The volume changes to the preset TA volume level if the current level is lower than the preset level (see page 16).

To activate TA Standby Reception



The TP (Traffic Programme) indicator either lights up or flashes.

- If the TP indicator lights up, TA Standby Reception is activated.
- If the TP indicator flashes, TA Standby Reception is not yet activated. (This occurs when you are listening to an FM station without the RDS signals required for TA Standby Reception.)

To activate TA Standby Reception, tune in to another station providing these signals. The TP indicator will stop flashing and remain lit.

To deactivate the TA Standby Reception



The TP indicator goes off.

PTY Standby Reception

PTY Standby Reception allows the unit to switch temporarily to your favorite PTY programme from any source other than AM.

To activate and select your favorite PTY code for PTY Standby Reception, see page 16.

- The PTY indicator either lights up or flashes.
- If the PTY indicator lights up, PTY Standby Reception is activated.
 - If the PTY indicator flashes, PTY Standby Reception is not yet activated.

To activate PTY Standby Reception, tune in to another station providing these signals. The PTY indicator will stop flashing and remain lit.

Continued on the next page

To deactivate the PTY Standby Reception, select "OFF" for the PTY code (see page 16). The PTY indicator goes off.

Tracing the same programme— Network-Tracking Reception

When driving in an area where FM reception is not sufficient enough, this unit automatically tunes in to another FM RDS station of the same network, possibly broadcasting the same programme with stronger signals (see the illustration below).

When shipped from the factory, Network-Tracking Reception is activated.

To change the Network-Tracking Reception setting, see "AF-REG" on page 16.

Programme A broadcasting on different frequency areas (01 – 05)

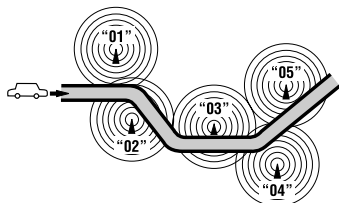

Automatic station selection— Programme Search

Usually when you press the number buttons, the preset station is tuned in.

If the signals from the FM RDS preset station are not sufficient for good reception, this unit, using the AF data, tunes in to another frequency broadcasting the same programme as the original preset station is broadcasting.

- The unit takes some time to tune in to another station using programme search.
- See also page 16.

To check the current clock time while listening to an FM RDS station



Station name (PS) → Station
Frequency → Programme
type (PTY) → Clock → (back to
the beginning)

PTY codes

NEWS, AFFAIRS, INFO, SPORT, EDUCATE, DRAMA, CULTURE, SCIENCE, VARIED, POP M (music), ROCK M (music), EASY M (music), LIGHT M (music), CLASSICS, OTHER M (music), WEATHER, FINANCE, CHILDREN, SOCIAL, RELIGION, PHONE IN, TRAVEL, LEISURE, JAZZ, COUNTRY, NATION M (music), OLDIES, FOLK M (music), DOCUMENT

Disc operations

Playing a disc in the unit

All tracks will be played repeatedly until you change the source or eject the disc.

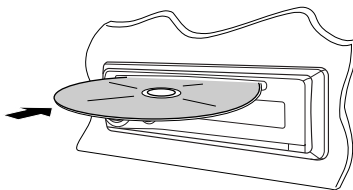

To stop play and eject the disc



- Press SRC to listen to another playback source.

To fast-forward or reverse the track



To go to the next or previous tracks



To go to the next or previous folders (only for MP3 or WMA discs)



To locate a particular track (for CD) or folder (for MP3 or WMA discs) directly

To select a number from 01 – 06:



To select a number from 07 – 12:



[Hold]

- To use direct folder access on MP3/WMA discs, it is required that folders are assigned with 2-digit numbers at the beginning of their folder names— 01, 02, 03, and so on.

To select a particular track in a folder (for MP3 or WMA disc):



Other main functions

■ Skipping tracks quickly during play

- For MP3 or WMA discs, you can skip tracks within the same folder.

Ex.: To select track 32 while playing tracks whose number is a single digit (1 to 9)

1 MODE



2

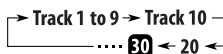

Each time you press the button, you can skip 10 tracks.

- After the last track, the first track will be selected and vice versa.

3

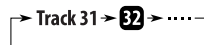

■ Prohibiting disc ejection

You can lock a disc in the loading slot.



+



[Hold]

NO EJECT

To cancel the prohibition, repeat the same procedure.

Changing the display information



While playing an audio CD or a CD Text



While playing an MP3 or a WMA track

- When "TAG DISP" is set to "TAG ON" (see page 17)



- When "TAG DISP" is set to "TAG OFF"



- A** : Elapsed playing time with the current track number
- B** : Clock with the current track number
- : Corresponding indicator lights up on the display

*1 If the current disc is an audio CD, "NO NAME" appears.

*2 If an MP3/WMA file does not have Tag information, folder name and file name appear. In this case, the TAG indicator will not light up.

Selecting the playback modes

You can use only one of the following playback modes at a time.

- MODE
- Select your desired playback mode.

Repeat play

11 RPT



Mode Plays repeatedly

TRK RPT : The current track.

FLDR RPT* : All tracks of the current folder.



RPT OFF : Cancels.

Random play

12 RND



Mode Plays at random

FLDR RND* : All tracks of the current folder, then tracks of the next folder and so on.



DISC RND : All tracks of the current disc.



RND OFF : Cancels.

* Only while playing an MP3 or a WMA disc.

: Corresponding indicator lights up on the display

iPod operations

You can play songs from an Apple iPod through this unit by connecting it with the supplied connection cable for iPod.

- Disconnecting the iPod will stop playback. Press SRC to listen to another playback source.

- For connection, see Installation/Connection Manual (separate volume).
- For details, refer also to the manual supplied with your iPod.

1 Connect an iPod.

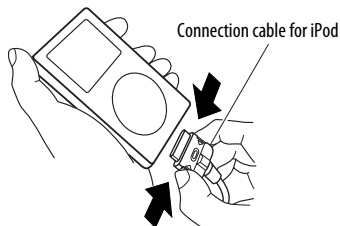

If an iPod has been connected...



Playback starts automatically from where it has been paused previously.

2 Adjust the volume.

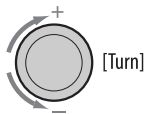

3 Adjust the sound as you want. (See pages 14 and 15.)

Caution:

- Avoid using the iPod if it might hinder your safety driving.
- Make sure all important data has been backed up to avoid losing the data.

To pause playback



To resume playback, press the button again.

To fast-forward or reverse the track



To go to the next or previous tracks



Selecting a track from the menu

1 Enter the main menu.



Now the $\blacktriangle/\blacktriangledown/\blacktriangleleft/\blacktriangleright/\blacktriangleright/\blacktriangleleft$ buttons work as the menu selecting buttons*.

2 Select the desired menu.



PLAYLIST \leftrightarrow ARTISTS \leftrightarrow ALBUMS \leftrightarrow
SONGS \leftrightarrow GENRES \leftrightarrow COMPOSER \leftrightarrow
(back to the beginning)

3 Confirm the selection.



To move back to the previous menu, press \blacktriangle .

- If a track is selected, playback starts automatically.
- If the selected item has another layer, you will enter the layer. Repeat steps 2 and 3 until the desired track is played (see page 21).
- Holding $\blacktriangleleft/\blacktriangleright/\blacktriangleleft/\blacktriangleright$ can skip 10 items at a time.

* The menu selecting mode will be canceled:

- If no operations are done for about 5 seconds.
- When you confirm the selection of a track.

Selecting the playback modes

1 MODE



2 Select your desired playback mode.

■ Repeat play

11 RPT



Mode **Playback functions (as on iPod)**

ONE RPT : Same as "Repeat One." 

ALL RPT : Same as "Repeat All." 



RPT OFF : Cancels.

■ Random play

12 RND



Mode **Playback functions (as on iPod)**

ALBM RND* : Same as "Shuffle Albums."  

SONG RND : Same as "Shuffle Songs." 

RND OFF : Cancels.

* Functions only if you select "ALL" in "ALBUMS" of the main "MENU."

 : Corresponding indicator lights up on the display

To check other information while listening to an iPod

DISP 

Sound adjustments

You can select a preset sound mode suitable to the music genre (iEQ: intelligent equalizer).

1 MODE

2   USER → ROCK → CLASSIC
 JAZZ ← HIP HOP ← POPS ←

Preset values	Preset values			
	BAS* ¹	MID* ²	TRE* ³	S.BS* ⁴
USER (Flat sound)	00	00	00	OFF
ROCK (Rock or disco music)	+03	00	+02	ON
CLASSIC (Classical music)	+01	00	+03	OFF
POPS (Light music)	+02	+01	+02	OFF
HIP HOP (Funk or rap music)	+04	-02	+01	ON
JAZZ (Jazz music)	+03	00	+03	OFF

*1 : Bass; *2 : Mid-range; *3 : Treble; *4 : Super bass

Adjusting the sound

You can adjust the sound characteristics to your preference.

1   → BAS → MID → TRE → FAD
 VOL ← S.BS ← BAL ←

2  [Turn]

Indication, [Range]**BAS** *¹ (bass), [-06 to +06]

Adjust the bass.

MID *¹ (mid-range), [-06 to +06]

Adjust the mid-range frequencies sound level.

TRE *¹ (treble), [-06 to +06]

Adjust the treble.

FAD *² (fader), [R06 to F06]

Adjust the front and rear speaker balance.

BAL (balance), [L06 to R06]

Adjust the left and right speaker balance.

S.BS *¹ (super bass), [S.BS ON or S.BS OFF],[01 to 05, initial: 03]*³

Maintain the richness and fullness of the bass sound regardless of how low you set the volume.

VOL (volume), [00 to 30 or 50 *⁴]

Adjust the volume.

*¹ When you adjust the bass, mid-range, treble, or super bass, the adjustment you have made is stored for the currently selected sound mode (iEQ) including "USER."

*² If you are using a two-speaker system, set the fader level to "00."

*³ Range adjustment for super bass is adjustable only when it is set to "S.BS ON."

*⁴ Depending on the amplifier gain control setting. (See page 17 for details.)

General settings — PSM

You can change PSM (Preferred Setting Mode) items listed in the table that follows.

1  [Hold]

2 Select a PSM item.



3 Adjust the PSM item selected.



4 Repeat steps 2 and 3 to adjust other PSM items if necessary.

5 Finish the procedure.



Continued on the next page

Indications	Item (___ : Initial)	Setting, [reference page]
DEMO Display demonstration	<ul style="list-style-type: none"> • DEMO ON • DEMO OFF 	<ul style="list-style-type: none"> : Display demonstration will be activated automatically if no operation is done for about 20 seconds, [6]. : Cancels.
CLK DISP * ¹ Clock display	<ul style="list-style-type: none"> • ON • OFF 	<ul style="list-style-type: none"> : Clock time is shown on the display at all times when the power is turned off. : Cancels; pressing DISP will show the clock time for about 5 seconds when the power is turned off, [6].
CLOCK H Hour adjustment	0 – 23 (1 – 12)	[Initial: 0 (0:00)], [6]
CLOCK M Minute adjustment	00 – 59	[Initial: 00 (0:00)], [6]
24H/12H Time display mode	<ul style="list-style-type: none"> • 24H • 12H 	: See also page 6 for setting.
CLK ADJ * ² Clock adjustment	<ul style="list-style-type: none"> • AUTO • OFF 	<ul style="list-style-type: none"> : The built-in clock is automatically adjusted using the CT (clock time) data in the RDS signal. : Cancels.
AF-REG * ² Alternative frequency/ regionalization reception	<ul style="list-style-type: none"> • AF • AF REG • OFF 	<ul style="list-style-type: none"> : When the currently received signals become weak, the unit switches to another station (the programme may differ from the one currently received), [10]. <ul style="list-style-type: none"> • The AF indicator lights up. : When the currently received signals become weak, the unit switches to another station broadcasting the same programme. <ul style="list-style-type: none"> • The AF and REG indicators light up. : Cancels.
PTY-STBY * ² PTY standby	OFF, PTY codes	Activates PTY Standby Reception with one of the PTY codes, [9, 10].
TA VOL * ² Traffic announcement volume	VOL 00 – VOL 30 or 50 * ³	[Initial: VOL 15]
P-SEARCH * ² Programme search	<ul style="list-style-type: none"> • ON • OFF 	<ul style="list-style-type: none"> : Activates Programme Search, [10]. : Cancels.

*¹ If the power supply is not interrupted by turning off the ignition key of your car, it is recommended to select "OFF" to save the car's battery.

*² Only for FM RDS stations.

*³ Depends on the amplifier gain control.

Indications	Item (__: Initial)	Setting, [reference page]
DIMMER Dimmer	<ul style="list-style-type: none"> • ON • OFF 	<ul style="list-style-type: none"> : Activates dimmer. : Cancels.
TEL Telephone muting	<ul style="list-style-type: none"> • MUTING 1/ MUTING 2 • OFF 	<ul style="list-style-type: none"> : Select either one which mutes the sounds while using a cellular phone. : Cancels.
SCROLL *4 Scroll	<ul style="list-style-type: none"> • ONCE • AUTO • OFF 	<ul style="list-style-type: none"> : Scrolls the track information once. : Repeats scrolling (at 5-second intervals). : Cancels. • Pressing DISP for more than one second can scroll the display regardless of the setting.
AUX ADJ Auxiliary input level adjustment	A.ADJ 00 – A.ADJ 05	: Adjust the auxiliary input level to avoid the sudden increase of the output level when changing the source from external component connected to the AUX input jack on the control panel.
TAG DISP Tag display	<ul style="list-style-type: none"> • TAG ON • TAG OFF 	<ul style="list-style-type: none"> : Shows the Tag information while playing MP3/WMA tracks, [12]. : Cancels.
AMP GAIN Amplifier gain control	<ul style="list-style-type: none"> • LOW PWR • HIGH PWR 	<ul style="list-style-type: none"> : VOL 00 – VOL 30 (Select this if the maximum power of the speaker is less than 50 W to prevent damaging the speaker.) : VOL 00 – VOL 50
IF BAND Intermediate frequency band	<ul style="list-style-type: none"> • AUTO • WIDE 	<ul style="list-style-type: none"> : Increases the tuner selectivity to reduce interference noises between close stations. (Stereo effect may be lost.) : Subject to interference noises from adjacent stations, but sound quality will not be degraded and the stereo effect will remain.

*4 Some characters or symbols will not be shown correctly (or will be blanked) on the display.

External component operations

You can connect an external component to the AUX (auxiliary) input jack on the control panel.

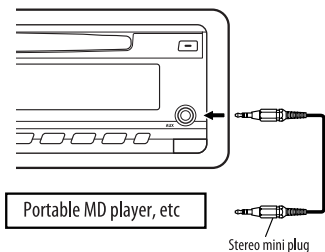

- 1 **SRC** → AUX IN →
- 2 **Turn on the connected component and start playing the source.**
- 3 **Adjust the volume.**

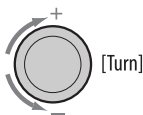

- 4 **Adjust the sound as you want. (See pages 14 and 15.)**

To check other information while listening to an external component



AUX IN ↔ Clock

More about this unit

Basic operations

Turning on the power

- By pressing SRC on the unit, you can also turn on the power. If the source is ready, playback also starts.

Turning off the power

- If you turn off the power while listening to a track, playback starts from where it has been stopped previously, next time you turn on the power.

General

- If you change the source while listening to a disc or an iPod, playback stops. Next time you select "CD" or "IPOD" as the playback source, playback starts from where it has been stopped/paused previously.
- After ejecting a disc or disconnecting an iPod, "NO DISC" or "NO IPOD" appears and you cannot operate some of the buttons. Insert another disc, reconnect an iPod, or press SRC to select another playback source.

Tuner operations

Storing stations in memory

- During SSM search...
 - All previously stored stations are erased and stations are stored newly.
 - Received stations are preset in No. 1 (lowest frequency) to No. 6 (highest frequency).
 - When SSM is over, the station stored in No. 1 will be automatically tuned in.
- When storing a station manually, the previously preset station is erased when a new station is stored in the same preset number.

FM RDS operations

- Network-Tracking Reception requires two types of RDS signals—PI (Programme Identification) and AF (Alternative Frequency) to work correctly. Without receiving these data correctly, Network-Tracking Reception will not operate correctly.

- If a Traffic Announcement is received by TA Standby Reception, the volume level automatically changes to the preset level (TA VOL) if the current level is lower than the preset level.
- When Alternative Frequency Reception is activated (with AF selected), Network-Tracking Reception is also activated automatically. (See page 16.)
- If you want to know more about RDS, visit <<http://www.rds.org.uk>>.
- The pickup lens inside the unit is dirty.
- CD-R/CD-RW on which the files are written with “Packet Write” method.
- There are improper recording conditions (missing data, etc.) or media conditions (stained, scratched, warped, etc.).
- CD-RWs may require a longer readout time since the reflectance of CD-RWs is lower than that of regular CDs.
- Do not use the following CD-Rs or CD-RWs:
 - Discs with stickers, labels, or a protective seal stuck to the surface.
 - Discs on which labels can be directly printed by an ink jet printer.

Using these discs under high temperatures or high humidities may cause malfunctions or damage to the unit.

Disc operations

Caution for DualDisc playback

- The Non-DVD side of a “DualDisc” does not comply with the “Compact Disc Digital Audio” standard. Therefore, the use of Non-DVD side of a DualDisc on this product may not be recommended.

General

- This unit has been designed to reproduce CDs/CD Texts, and CD-Rs (Recordable)/CD-RWs (Rewritable) in audio CD (CD-DA), MP3 and WMA formats.
- When a disc is inserted upside down, “PLEASE” and “EJECT” appear alternately on the display. Press **▲** to eject the disc.
- MP3 and WMA “tracks” (words “file” and “track” are used interchangeably) are recorded in “folders.”
- While fast-forwarding or reversing on an MP3 or WMA disc, you can only hear intermittent sounds.

Playing a CD-R or CD-RW

- Use only “finalized” CD-Rs or CD-RWs.
- This unit can play back only files of the same type which are first detected if a disc includes both audio CD (CD-DA) files and MP3/WMA files.
- This unit can play back multi-session discs; however, unclosed sessions will be skipped while playing.
- Some CD-Rs or CD-RWs may not play back on this unit because of their disc characteristics, or for the following reasons:
 - Discs are dirty or scratched.
 - Moisture condensation occurs on the lens inside the unit.

Playing an MP3/WMA disc

- This unit can play back MP3/WMA files with the extension code <.mp3> or <.wma> (regardless of the letter case—upper/lower).
- This unit can show the names of albums, artists (performer), and Tag (Version 1.0, 1.1, 2.2, 2.3, or 2.4) for MP3 files and for WMA files.
- This unit can display only one-byte characters. No other characters can be correctly displayed.
- This unit can play back MP3/WMA files meeting the conditions below:
 - Bit rate: 8 kbps — 320 kbps
 - Sampling frequency: 48 kHz, 44.1 kHz, 32 kHz (for MPEG-1) 24 kHz, 22.05 kHz, 16 kHz (for MPEG-2)
 - Disc format: ISO 9660 Level 1/ Level 2, Romeo, Joliet, Windows long file name
- The maximum number of characters for file/folder names vary among the disc format used (includes 4 extension characters—<.mp3> or <.wma>).
 - ISO 9660 Level 1: up to 12 characters
 - ISO 9660 Level 2: up to 31 characters
 - Romeo: up to 128 characters
 - Joliet: up to 64 characters
 - Windows long file name: up to 128 characters

Continued on the next page

- This unit can recognize a total of 512 files, of 200 folders, and of 8 hierarchies.
- This unit can play back files recorded in VBR (variable bit rate).
Files recorded in VBR have a discrepancy in elapsed time display, and do not show the actual elapsed time. Especially, after performing the search function, this difference becomes noticeable.
- This unit cannot play back the following files:
 - MP3 files encoded with MP3i and MP3 PRO format.
 - MP3 files encoded in an inappropriate format.
 - MP3 files encoded with Layer 1/2.
 - WMA files encoded with lossless, professional, and voice format.
 - WMA files which are not based upon Windows Media® Audio.
 - WMA files copy-protected with DRM.
 - Files which have the data such as AIFF, ATAC3, etc.
- The search function works but search speed is not constant.
- If your iPod software version is older than those mentioned above, you may not be able to control the iPod properly. Update your iPod to the latest software version before using it with this unit.
 - You can check the software version of your iPod from “About” in the “Setting” menu of the iPod.
 - For details about updating your iPod, visit <<http://www.apple.com>>.
- When you turn on this unit, the iPod is charged through this unit.
- While the iPod is connected, all operations from the iPod are disabled. Perform all operations from this unit.
- While connecting an iPod with Video:
 - No video shows on the iPod’s display or the external monitor (only the audio part is available).
 - It is not possible to browse video files on the “Video” menu. (If you connect the iPod during playback or pausing of a video file, resuming playback will not work.)
- iPod shuffle is not controllable.
- You can control the iPod from this unit when “JVC” or “√” appears on the iPod display.
- The songs order displayed on the selecting menu of this unit may differ from the iPod.
- If playback is stopped, select a track from the selecting menu or press ▼.
- The text information may not be displayed correctly.
 - Some characters such as accented letters cannot be shown correctly on the display.
 - Depends on the condition of communication between the iPod and the unit.
- If the text information includes more than 8 characters, it scrolls on the display. This unit can display up to 40 characters.

Ejecting a disc

- If the ejected disc is not removed within 15 seconds, the disc is automatically inserted again into the loading slot to protect it from dust. Playback starts automatically.

iPod operations

Controllable iPod	Software version
iPod with dock connector (3rd Generation)	2.3 or later
iPod with Click Wheel (4th Generation)	3.1 or later
iPod mini	1.4 or later
iPod photo	1.2 or later
iPod nano	1.0 or later
iPod with Video (5th Generation)	1.0 or later

General settings—PSM

- If you change the “AMP GAIN” setting from “HIGH PWR” to “LOW PWR” while the volume level is set higher than “VOL 30,” the unit automatically changes the volume level to “VOL 30.”

Hierarchical structure of file searching when an iPod is connected

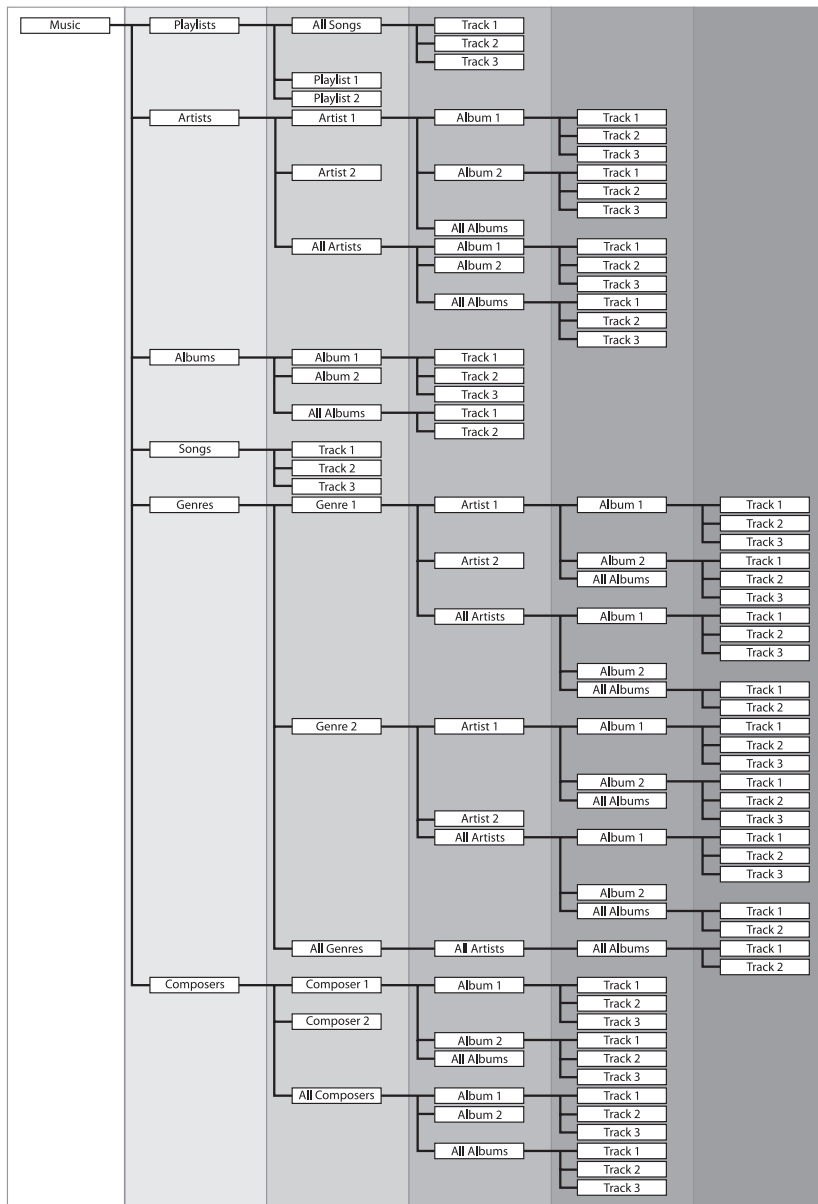

Maintenance

How to clean the connectors

Frequent detachment will deteriorate the connectors. To minimize this possibility, periodically wipe the connectors with a cotton swab or cloth moistened with alcohol, being careful not to damage the connectors.

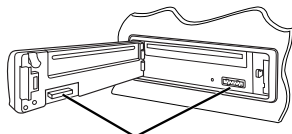

Connector

Moisture condensation

Moisture may condense on the lens inside the unit in the following cases:

- After starting the heater in the car.
- If it becomes very humid inside the car.

Should this occur, the unit may malfunction. In this case, eject the disc and leave the unit turned on for a few hours until the moisture evaporates.

How to handle discs

When removing a disc from its case, press down the center holder of the case and lift the disc out, holding it by the edges.

- Always hold the disc by the edges.
- Do not touch its recording surface.

When storing a disc into its case, gently insert the disc around the center holder (with the printed surface facing up).

- Make sure to store discs into the cases after use.

Center holder



To keep discs clean

A dirty disc may not play correctly. If a disc does become dirty, wipe it with a soft cloth in a straight line from center to edge.



- Do not use any solvent (for example, conventional record cleaner, spray, thinner, benzene, etc.) to clean discs.

To play new discs

New discs may have some rough spots around the inner and outer edges. If such a disc is used, this unit may reject the disc.



To remove these rough spots, rub the edges with a pencil or ball-point pen, etc.

Do not use the following discs:

Warped disc 

Sticker  Sticker residue

 Stick-on label

 Unusual shape

 Single CD (8 cm disc)

Troubleshooting

What appears to be trouble is not always serious. Check the following points before calling a service center.

	Symptoms	Remedies/Causes
General	<ul style="list-style-type: none"> • Sound cannot be heard from the speakers. 	<ul style="list-style-type: none"> • Adjust the volume to the optimum level. • Check the cords and connections.
	<ul style="list-style-type: none"> • The unit does not work at all. 	Reset the unit (see page 2).
FM/AM	<ul style="list-style-type: none"> • SSM automatic presetting does not work. 	Store stations manually.
	<ul style="list-style-type: none"> • Static noise while listening to the radio. 	Connect the aerial firmly.
Disc playback	<ul style="list-style-type: none"> • Disc cannot be played back. 	Insert the disc correctly.
	<ul style="list-style-type: none"> • CD-R/CD-RW cannot be played back. • Tracks on the CD-R/CD-RW cannot be skipped. 	<ul style="list-style-type: none"> • Insert a finalized CD-R/CD-RW. • Finalize the CD-R/CD-RW with the component which you used for recording.
	<ul style="list-style-type: none"> • Disc can neither be played back nor ejected. 	<ul style="list-style-type: none"> • Unlock the disc (see page 11). • Eject the disc forcibly (see page 2).
	<ul style="list-style-type: none"> • Disc sound is sometimes interrupted. 	<ul style="list-style-type: none"> • Stop playback while driving on rough roads. • Change the disc. • Check the cords and connections.
	<ul style="list-style-type: none"> • "NO DISC" appears on the display. 	Insert a playable disc into the loading slot.
MP3/WMA playback	<ul style="list-style-type: none"> • Disc cannot be played back. 	<ul style="list-style-type: none"> • Use a disc with MP3/WMA tracks recorded in the format compliant with ISO 9660 Level 1, Level 2, Romeo, or Joliet. • Add the extension code <.mp3> or <.wma> to the file names.
	<ul style="list-style-type: none"> • Noise is generated. 	Skip to another track or change the disc. (Do not add the extension code <.mp3> or <.wma> to non-MP3 or WMA tracks.)
	<ul style="list-style-type: none"> • A longer readout time is required ("CHECK" keeps flashing on the display). 	Do not use too many hierarchies and folders.

Continued on the next page

	Symptoms	Remedies/Causes
MP3/WMA playback	• Tracks do not play back in the order you have intended them to play.	Playback order is determined when the files are recorded.
	• Elapsed playing time is not correct.	This sometimes occurs during play. This is caused by how the tracks are recorded on the disc.
	• "PLEASE" and "EJECT" appear alternately on the display.	Insert a disc that contains MP3/WMA tracks.
	• Correct characters are not displayed (e.g. album name).	This unit can only display letters (upper case), numbers, and a limited number of symbols.
iPod playback	• The iPod does not turn on or does not work.	<ul style="list-style-type: none"> • Check the connecting cable and its connection. • Update the firmware version. • Charge the battery.
	• The sound is distorted.	Deactivate the equalizer either on the unit or the iPod.
	• "NO IPOD" appears on the display.	<ul style="list-style-type: none"> • Check the connecting cable and its connection. • Charge the battery.
	• Playback stops.	The headphones are disconnected during playback. Turn off the unit's power and turn it on again.
	• No sound can be heard when connecting an iPod nano.	<ul style="list-style-type: none"> • Disconnect the headphones from the iPod nano. • Update the firmware version of the iPod nano.
	• "NO FILES" appears on the display.	No tracks are stored. Import tracks to the iPod.
	• "RESET 1" – "RESET 7" appears on the display.	Reconnect the iPod.
	• "RESET 8" appears on the display.	Check the connecting cable and its connection.
• The iPod's controls do not work after disconnecting from this unit.	Reset the iPod.	

- Microsoft and Windows Media are either registered trademarks or trademarks of Microsoft Corporation in the United States and/or other countries.
- iPod is a trademark of Apple Computer, Inc., registered in the U.S. and other countries.

Specifications

AUDIO AMPLIFIER SECTION

Maximum Power Output:	
Front/Rear:	50 W per channel
Continuous Power Output (RMS):	
Front/Rear:	19 W per channel into 4 Ω , 40 Hz to 20 000 Hz at no more than 0.8% total harmonic distortion.
Load Impedance:	4 Ω (4 Ω to 8 Ω allowance)
Tone Control Range:	
Bass/Mid-range/ Treble:	± 12 dB at 60 Hz/1 kHz/ 7.5 kHz
Frequency Response:	40 Hz to 20 000 Hz
Signal-to-Noise Ratio:	70 dB
Line-Out Level Impedance:	2.5 V/20 k Ω load (full scale)
Output Impedance:	1 k Ω
Other Terminal:	AUX (auxiliary) input jack, iPod jack, Steering wheel remote input

TUNER SECTION

Frequency Range:	
FM:	87.5 MHz to 108.0 MHz
AM:	MW: 522 kHz to 1 620 kHz LW: 144 kHz to 279 kHz
FM Tuner	
Usable Sensitivity:	11.3 dBf (1.0 μ V/75 Ω)
50 dB Quietening Sensitivity:	16.3 dBf (1.8 μ V/75 Ω)
Alternate Channel Selectivity (400 kHz):	65 dB
Frequency Response:	40 Hz to 15 000 Hz
Stereo Separation:	30 dB
MW Tuner	
Sensitivity/Selectivity:	20 μ V/35 dB
LW Tuner	
Sensitivity:	50 μ V

CD PLAYER SECTION

Type:	Compact disc player
Signal Detection System:	Non-contact optical pickup (semiconductor laser)
Number of Channels:	2 channels (stereo)
Frequency Response:	5 Hz to 20 000 Hz
Dynamic Range:	96 dB
Signal-to-Noise Ratio:	98 dB
Wow and Flutter:	Less than measurable limit
MP3 Decoding Format: (MPEG1/2 Audio Layer 3)	
Max. Bit Rate:	320 kbps
WMA (Windows Media® Audio) Decoding Format:	
Max. Bit Rate:	192 kbps

GENERAL

Power Requirement:	
Operating Voltage:	DC 14.4 V (11 V to 16 V allowance)
Grounding System:	Negative ground
Allowable Operating Temperature:	0°C to +40°C
Dimensions (W \times H \times D): (approx.)	
Installation Size:	182 mm \times 52 mm \times 150 mm
Panel Size:	187 mm \times 58 mm \times 13 mm
Mass:	1.3 kg (excluding accessories)

Design and specifications are subject to change without notice.

**Having TROUBLE with operation?
Please reset your unit**

Refer to page of How to reset your unit

**Vous avez des PROBLÈMES de fonctionnement?
Réinitialisez votre appareil**

Référez-vous à la page intitulée Comment réinitialiser votre appareil

Dear Customer,

This apparatus is in conformance with the valid European directives and standards regarding electromagnetic compatibility and electrical safety.

European representative of Victor Company of Japan, Limited is:

JVC Technology Centre Europe GmbH
Postfach 10 05 52
61145 Friedberg
Germany

Cher(e) client(e),

Cet appareil est conforme aux directives et normes européennes en vigueur concernant la compatibilité électromagnétique et à la sécurité électrique.

Représentant européen de la société Victor Company of Japan, Limited:

JVC Technology Centre Europe GmbH
Postfach 10 05 52
61145 Friedberg
Allemagne

JVC



EN, FR

© 2007 Victor Company of Japan, Limited

0107DTSMDTJEIN

JVC KD-PDR31

Installation/Connection Manual Manuel d'installation/raccordement

GET0469-010A
[EX/EU]

0107DTSMDTJEIN
EN, FR

© 2007 Victor Company of Japan, Limited

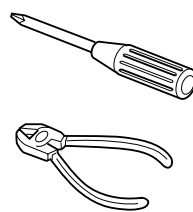

ENGLISH

This unit is designed to operate on **12 V DC, NEGATIVE ground electrical systems**. If your vehicle does not have this system, a voltage inverter is required, which can be purchased at JVC IN-CAR ENTERTAINMENT dealers.

WARNINGS

To prevent short circuits, we recommend that you disconnect the battery's negative terminal and make all electrical connections before installing the unit.

- **Be sure to ground this unit to the car's chassis again after installation.**

Notes:

- Replace the fuse with one of the specified rating. If the fuse blows frequently, consult your JVC IN-CAR ENTERTAINMENT dealer.
- It is recommended to connect to the speakers with maximum power of more than 50 W (both at the rear and at the front, with an impedance of **4 Ω to 8 Ω**). If the maximum power is less than 50 W, change "AMP GAIN" setting to prevent the speakers from being damaged (see page 17 of the INSTRUCTIONS).
- To prevent short-circuit, cover the terminals of the UNUSED leads with insulating tape.
- The heat sink becomes very hot after use. Be careful not to touch it when removing this unit.

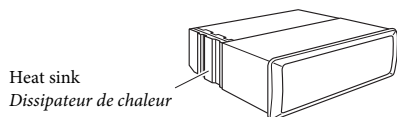

FRANÇAIS

Cet appareil est conçu pour fonctionner sur des sources de **courant continu de 12 V à masse NEGATIVE**. Si votre véhicule n'offre pas ce type d'alimentation, il vous faut un convertisseur de tension, que vous pouvez acheter chez un revendeur d'autoradios JVC.

AVERTISSEMENTS

Pour éviter tout court-circuit, nous vous recommandons de débrancher la borne négative de la batterie et d'effectuer tous les raccordements électriques avant d'installer l'appareil.

- **Assurez-vous de raccorder de nouveau la mise à la masse de cet appareil au châssis de la voiture après l'installation.**

Remarques:

- Remplacer le fusible par un de la valeur précisée. Si le fusible saute souvent, consulter votre revendeur d'autoradios JVC.
- Il est recommandé de connecter des enceintes avec une puissance de plus de 50 W (les enceintes arrière et les enceintes avant, avec une impédance comprise entre **4 Ω et 8 Ω**). Si la puissance maximum est inférieure à 50 W, changez "AMP GAIN" pour éviter d'endommager vos enceintes (voir page 17 du MANUEL D'INSTRUCTIONS).
- Pour éviter les court-circuits, couvrir les bornes des fils qui ne sont PAS UTILISÉS avec de la bande isolante.
- Le dissipateur de chaleur devient très chaud après usage. Faire attention de ne pas le toucher en retirant cet appareil.

PRECAUTIONS on power supply and speaker connections:

- **DO NOT connect the speaker leads of the power cord to the car battery; otherwise, the unit will be seriously damaged.**
- BEFORE connecting the speaker leads of the power cord to the speakers, check the speaker wiring in your car.

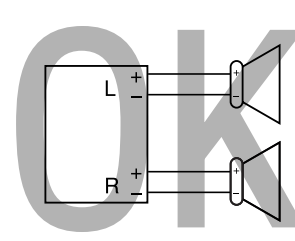
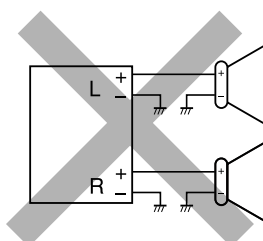
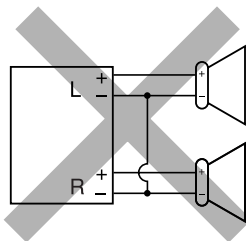

PRECAUTIONS sur l'alimentation et la connexion des enceintes:

- **NE CONNECTEZ PAS les fils d'enceintes du cordon d'alimentation à la batterie; sinon, l'appareil serait sérieusement endommagé.**
- AVANT de connecter les fils d'enceintes du cordon d'alimentation aux enceintes, vérifiez le câblage des enceintes de votre voiture.

Parts list for installation and connection

The following parts are provided for this unit. If any item is missing, consult your JVC IN-CAR ENTERTAINMENT dealer immediately.

Liste des pièces pour l'installation et raccordement

Les pièces suivantes sont fournies avec cet appareil. Si quelque chose manquait, consultez votre revendeur autoradio JVC immédiatement.

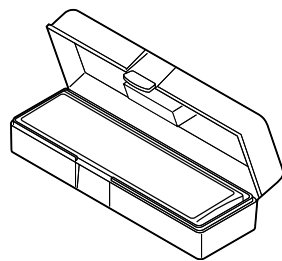

(A) / (B)
Hard case/Control panel
Etui de transport/Panneau de commande

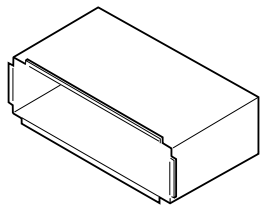

(C)
Sleeve
Manchon

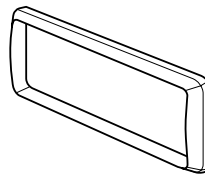

(D)
Trim plate
Plaque d'assemblage

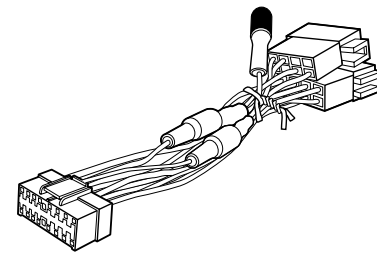

(E)
Power cord
Cordon d'alimentation

(F)
Connection cable for iPod
Câble de connexion pour iPod

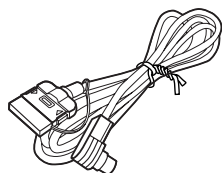

(G)
Cable tie
Collier pour câble

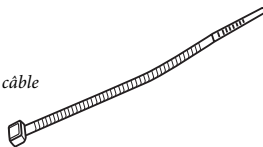

(H)
Washer (ø5)
Rondelle (ø5)



(I)
Lock nut (M5)
Ecrou d'arrêt (M5)



(J)
Mounting bolt (M5 × 20 mm)
Boulon de montage (M5 × 20 mm)

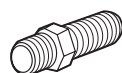

(K)
Rubber cushion
Amortisseur en caoutchouc



(L)
Handles
Poignées

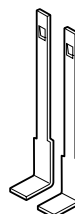

(M)
Remote controller
Télécommande



RM-RK50

(N)
Battery
Pile



CR2025

INSTALLATION (IN-DASH MOUNTING)

The following illustration shows a typical installation. If you have any questions or require information regarding installation kits, consult your JVC IN-CAR ENTERTAINMENT dealer or a company supplying kits.

- If you are not sure how to install this unit correctly, have it installed by a qualified technician.

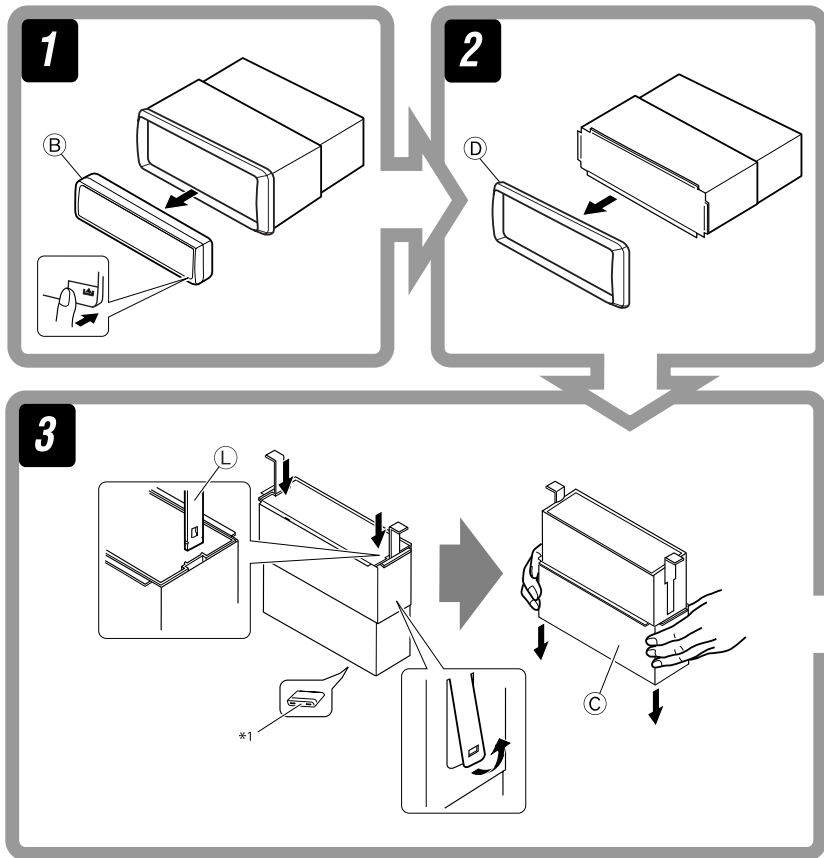

INSTALLATION (MONTAGE DANS LE TABLEAU DE BORD)

L'illustration suivante est un exemple d'installation typique. Si vous avez des questions ou avez besoin d'information sur des kits d'installation, consulter votre revendeur d'autoradios JVC ou une compagnie d'approvisionnement.

- Si l'on n'est pas sûr de pouvoir installer correctement cet appareil, le faire installer par un technicien qualifié.

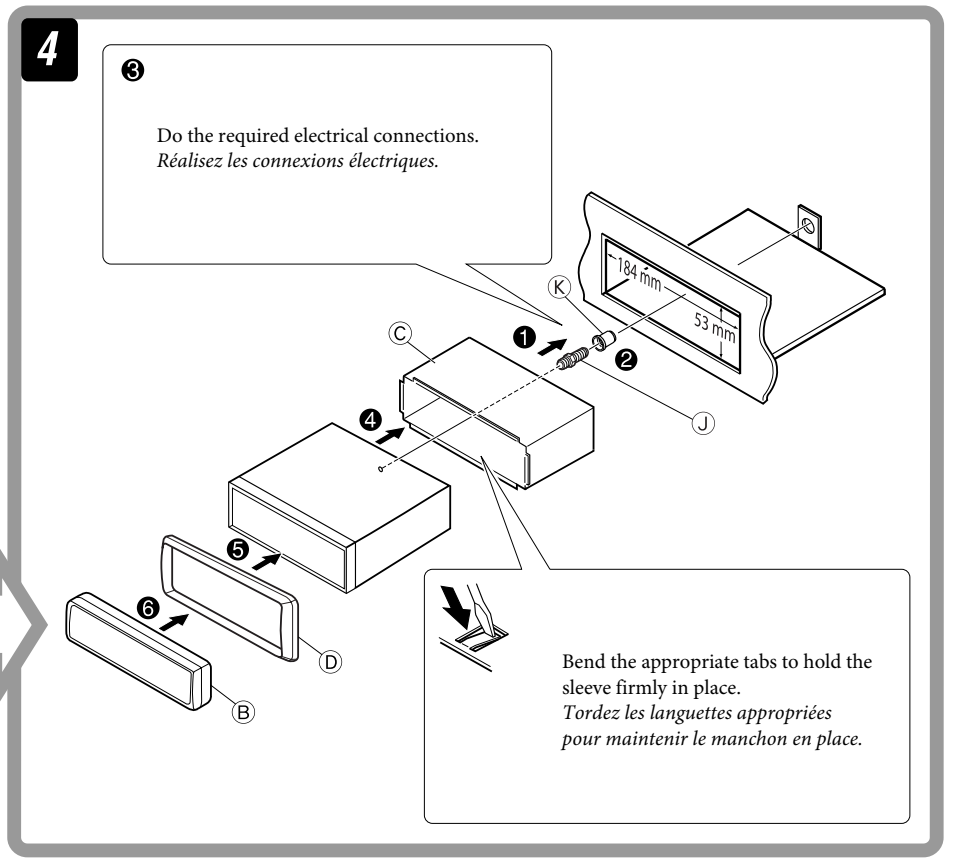

Removing the unit

Before removing the unit, release the rear section.

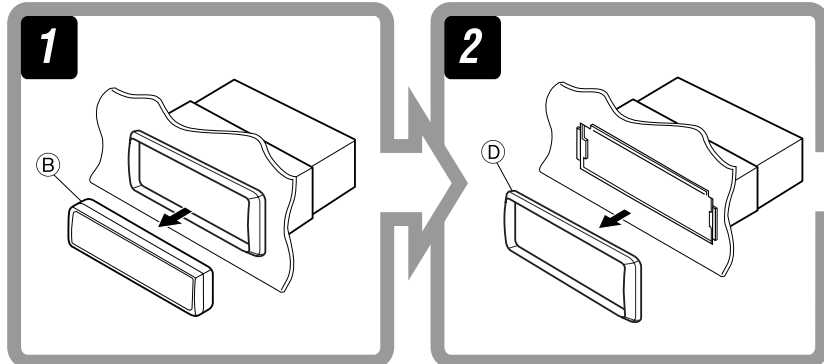

Retrait de l'appareil

Avant de retirer l'appareil, libérer la section arrière.

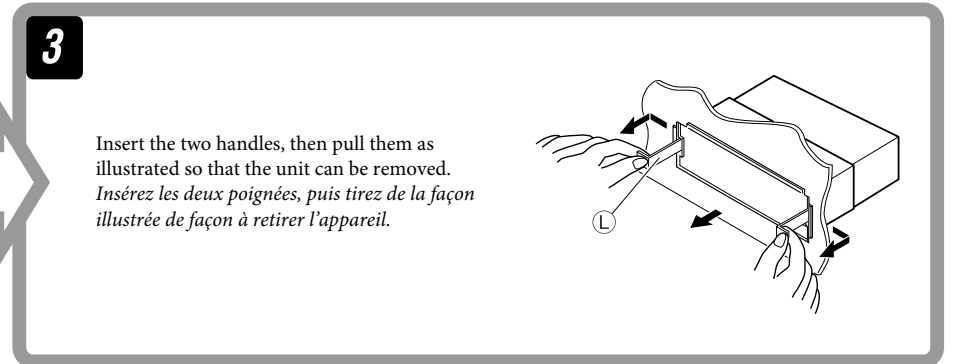

When using the optional stay / Lors de l'utilisation du hauban en option

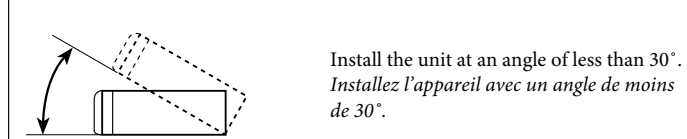
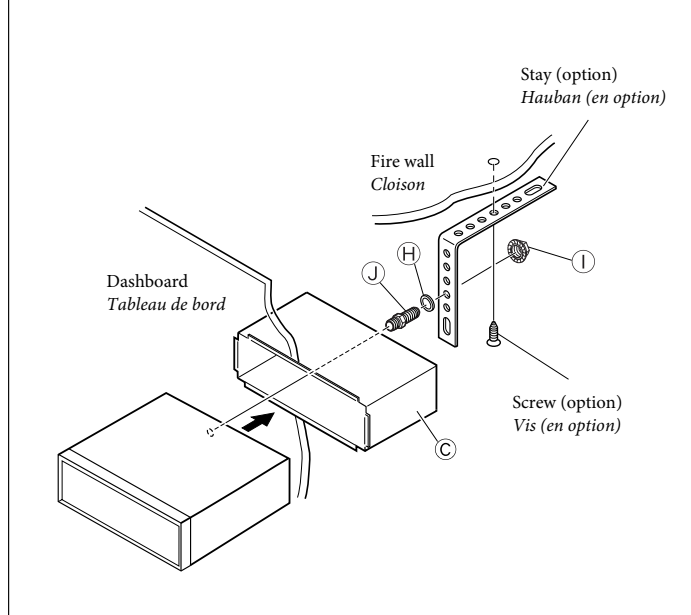

*1 When you stand the unit, be careful not to damage the fuse on the rear.
*2 Not supplied for this unit.

When installing the unit without using the sleeve / Lors de l'installation de l'appareil sans utiliser de manchon

In a Toyota car for example, first remove the car radio and install the unit in its place. Dans une voiture Toyota, par exemple, retirez d'abord l'autoradio et installez l'appareil à sa place.

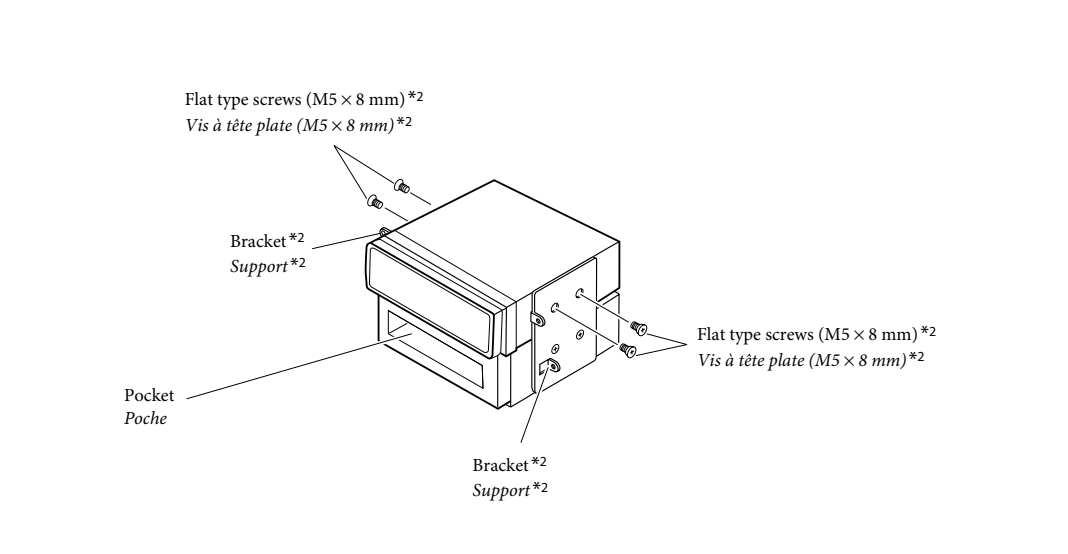

Note : When installing the unit on the mounting bracket, make sure to use the 8 mm-long screws. If longer screws are used, they could damage the unit.
Remarque : Lors de l'installation de l'appareil sur le support de montage, s'assurer d'utiliser des vis d'une longueur de 8 mm. Si des vis plus longues sont utilisées, elles peuvent endommager l'appareil.

*1 Lorsque vous mettez l'appareil à la verticale, faire attention de ne pas endommager le fusible situé sur l'arrière.
*2 Non fourni avec cet autoradio.

ELECTRICAL CONNECTIONS

RACCORDEMENTS ELECTRIQUES

A If your car is equipped with the ISO connector / Si votre voiture est équipée d'un connecteur ISO

- Connect the ISO connectors as illustrated.
- Connectez les connecteurs ISO comme montré sur l'illustration.

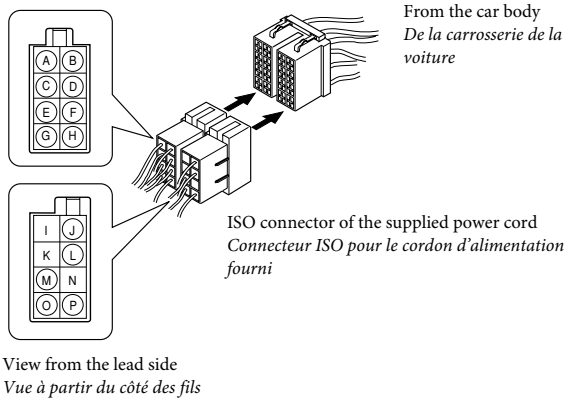

For some VW/Audi or Opel (Vauxhall) automobile / Pour certaine voiture VW/Audi ou Opel (Vauxhall)

You may need to modify the wiring of the supplied power cord as illustrated.

- Contact your authorized car dealer before installing this unit.
- Vous aurez peut-être besoin de modifier le câblage du cordon d'alimentation fourni comme montré sur l'illustration.
- Contactez votre revendeur automobile autorisé avant d'installer l'appareil.

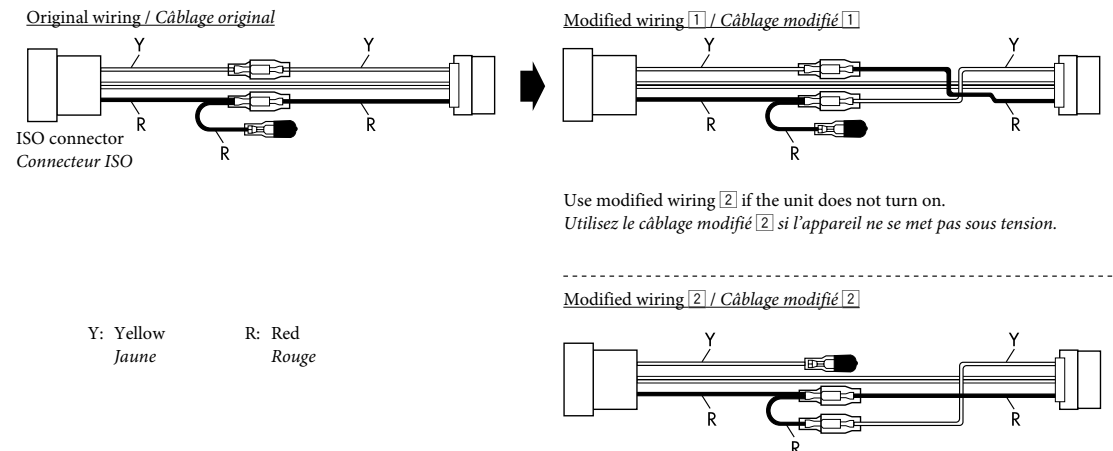

Y: Yellow / Jaune
R: Red / Rouge

B Connections without using the ISO connectors / Connexions sans l'utilisation des connecteurs ISO

Before connecting: Check the wiring in the vehicle carefully. Incorrect connection may cause serious damage to this unit.

The leads of the power cord and those of the connector from the car body may be different in color.

- 1 Cut the ISO connector.
- 2 Connect the colored leads of the power cord in the order specified in the illustration below.
- 3 Connect the aerial cord.
- 4 Finally connect the wiring harness to the unit.

Avant de commencer la connexion: Vérifiez attentivement le câblage du véhicule. Une connexion incorrecte peut endommager sérieusement l'appareil.

The fil du cordon d'alimentation et ceux des connecteurs du châssis de la voiture peuvent être différents en couleur.

- 1 Coupez le connecteur ISO.
- 2 Connectez les fils colorés du cordon d'alimentation dans l'ordre spécifié sur l'illustration ci-dessous.
- 3 Connectez le cordon d'antenne.
- 4 Finalement, connectez le faisceau de fils à l'appareil.

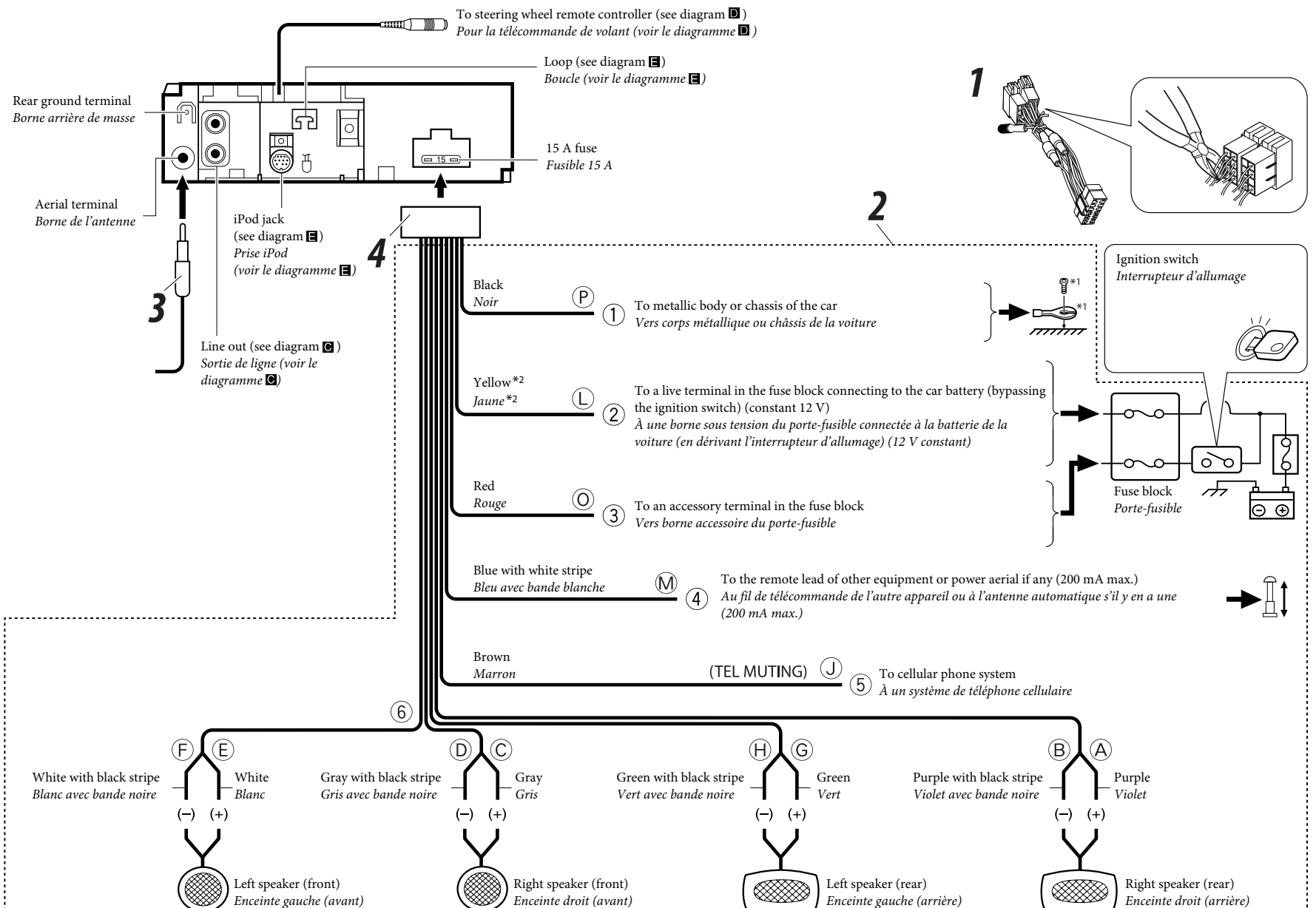

*1 Not supplied for this unit.

*2 Before checking the operation of this unit prior to installation, this lead must be connected, otherwise power cannot be turned on.

*1 Non fourni avec cet autoradio.

*2 Pour vérifier le fonctionnement de cet appareil avant installation, ce fil doit être raccordé, sinon l'appareil ne peut pas être mis sous tension.

C Connecting the external amplifier / Connexion d'un amplificateur extérieur

You can connect an amplifier to upgrade your car stereo system.

- Connect the remote lead (blue with white stripe) to the remote lead of the other equipment so that it can be controlled through this unit.
- **Disconnect the speakers from this unit, connect them to the amplifier. Leave the speaker leads of this unit unused.**

Vous pouvez connecter un amplificateur pour améliorer votre système autoradio.

- Connectez le fil de commande à distance (bleu avec bande blanche) au fil de commande à distance de l'autre appareil de façon qu'il puisse être commandé via cet appareil.
- **Déconnectez les enceintes de cet appareil et connectez-les à l'amplificateur. Laissez les fils d'enceintes de cet appareil inutilisés.**

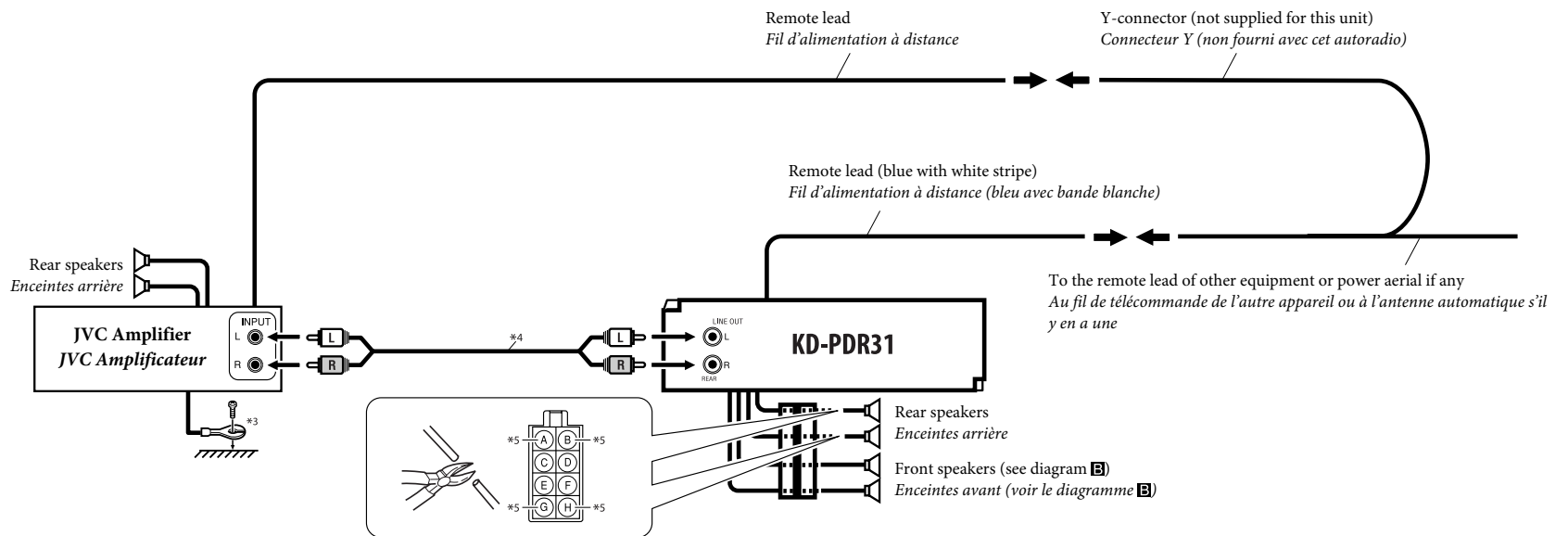

D Connecting to the steering wheel remote controller / Connexion de la télécommande de volant

If your car is equipped with the steering wheel remote controller, you can operate this unit using the controller. To do it, a JVC's OE remote adapter (not supplied) which matches with your car is required. Consult your JVC IN-CAR ENTERTAINMENT dealer for details.

Si votre voiture est munie d'une télécommande de volant, vous pouvez commander cet autoradio en utilisant la télécommande. Pour le faire, un adaptateur pour télécommande au volant JVC (non fourni) correspondant à votre voiture est nécessaire. Consultez votre revendeur d'autoradio JVC pour les détails.

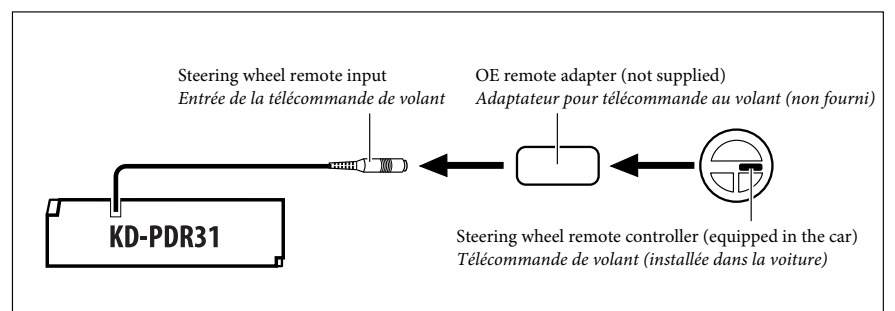

E Connecting an Apple iPod / Connexion d'un iPod Apple

You can connect an iPod to this unit using the supplied connection cable for iPod.

- 1 Insert the supplied cable tie across the loop.
- 2 Press in the head of the connection cable for iPod until you hear a clicking sound.
- 3 Fasten the connection cable using the cable tie to firmly hold the connection cable in place.

Vous pouvez connecter un iPod à cet appareil en utilisant le câble de connexion du iPod fourni.

- 1 Insérez le collier pour câble fourni dans la boucle.
- 2 Faites pression sur la tête du câble de connexion pour iPod jusqu'à ce que vous entendiez un déclic.
- 3 Fixez le câble de connexion en utilisant le collier pour câble pour le maintenir solidement le câble de connexion en place.

iPod is a trademark of Apple Computer, Inc., registered in the U.S. and other countries.
iPod est une marque de commerce d'Apple Computer, Inc., enregistrée aux États-Unis et dans les autres pays.

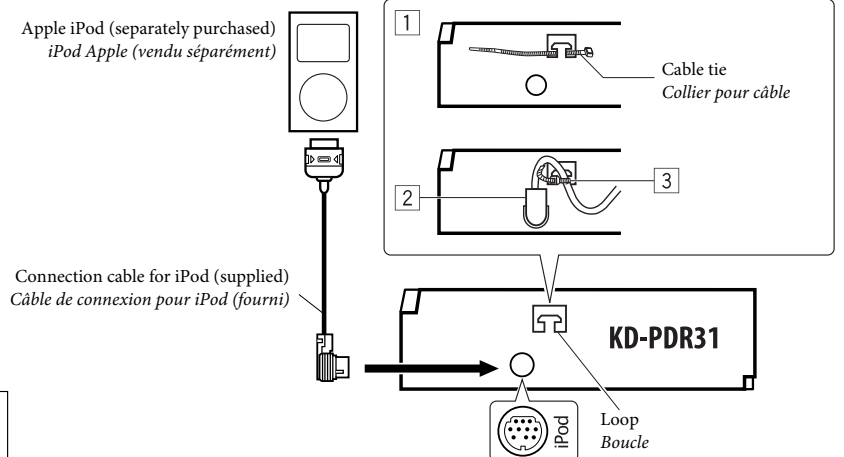

*3 Firmly attach the ground wire to the metallic body or to the chassis of the car—to the place uncoated with paint (if coated with paint, remove the paint before attaching the wire). Failure to do so may cause damage to the unit.

*4 Signal cord (not supplied for this unit)

*5 Cut the rear speaker leads of the car's ISO connector and connect them to the amplifier.

*3 Attachez solidement le fil de mise à la masse au châssis métallique de la voiture—à un endroit qui n'est pas recouvert de peinture (s'il est recouvert de peinture, enlevez d'abord la peinture avant d'attacher le fil). L'appareil peut être endommagé si cela n'est pas fait correctement.

*4 Cordon de signal (non fourni avec cet autoradio)

*5 Coupez les fils des enceintes arrière du connecteur ISO de la voiture et connectez-les à l'amplificateur.

TROUBLESHOOTING

• The fuse blows.

* Are the red and black leads connected correctly?

• Power cannot be turned on.

* Is the yellow lead connected?

• No sound from the speakers.

* Is the speaker output lead short-circuited?

• Sound is distorted.

* Is the speaker output lead grounded?

* Are the “-” terminals of L and R speakers grounded in common?

• Noise interferes with sounds.

* Is the rear ground terminal connected to the car's chassis using shorter and thicker cords?

• This unit becomes hot.

* Is the speaker output lead grounded?

* Are the “-” terminals of L and R speakers grounded in common?

• This unit does not work at all.

* Have you reset your unit?

EN CAS DE DIFFICULTES

• Le fusible saute.

* Les fils rouge et noir sont-ils raccordés correctement?

• L'appareil ne peut pas être mis sous tension.

* Le fil jaune est-elle raccordée?

• Pas de son des enceintes.

* Le fil de sortie d'enceinte est-il court-circuité?

• Le son est déformé.

* Le fil de sortie d'enceinte est-il à la masse?

* Les bornes “-” des enceintes gauche et droit sont-elles mises ensemble à la masse?

• Interférence avec les sons.

* La prise arrière de mise à la terre est-elle connectée au châssis de la voiture avec un cordon court et épais?

• Cet appareil devient chaud.

* Le fil de sortie d'enceinte est-il à la masse?

* Les bornes “-” des enceintes gauche et droit sont-elles mises ensemble à la masse?

• Cet appareil ne fonctionne pas du tout.

* Avez-vous réinitialisé votre appareil?

JVC

ENGLISH

DEUTSCH

РУССКИЙ

CD RECEIVER
CD-RECEIVER
РЕСИВЕР С ПРОИГРЫВАТЕЛЕМ КОМПАКТ-ДИСКОВ

KD-PDR31

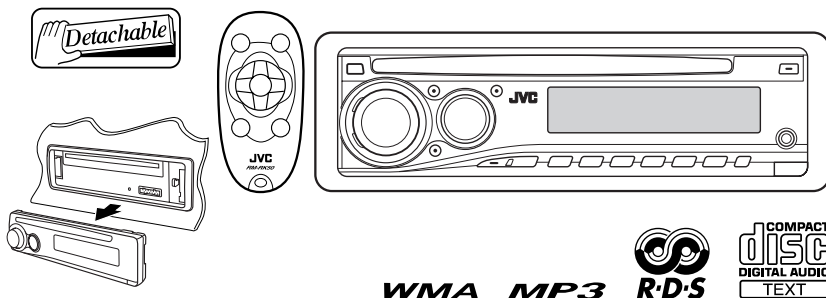

For canceling the display demonstration, see page 6.

Zum Abbrechen der Displaydemonstration siehe Seite 6.

Информацию об отмене демонстрации функций дисплея см. на стр. 6.

For installation and connections, refer to the separate manual.

Für den Einbau und die Anschlüsse siehe das eigenständige Handbuch.

Указания по установке и выполнению соединений приводятся в отдельной инструкции.

INSTRUCTIONS

BEDIENUNGSANLEITUNG
ИНСТРУКЦИИ ПО ЭКСПЛУАТАЦИИ

GET0469-006A
[EY]



Thank you for purchasing a JVC product.

Please read all instructions carefully before operation, to ensure your complete understanding and to obtain the best possible performance from the unit.

IMPORTANT FOR LASER PRODUCTS

1. CLASS 1 LASER PRODUCT
2. **CAUTION:** Do not open the top cover. There are no user serviceable parts inside the unit; leave all servicing to qualified service personnel.
3. **CAUTION:** Visible and/or invisible class 1M laser radiation when open. Do not view directly with optical instruments.
4. REPRODUCTION OF LABEL: CAUTION LABEL, PLACED OUTSIDE THE UNIT.

CAUTION VISIBLE AND/OR INVISIBLE CLASS 1M LASER RADIATION WHEN OPEN. DO NOT VIEW DIRECTLY WITH OPTICAL INSTRUMENTS IEC60825-1:2001 (EN3)	ATTENTION RAYONNEMENT LASER VISIBLE ET/OU INVISIBLE DE CLASSE 1M UNE FOIS OUVERT NE PAS REGARDER DIRECTEMENT AVEC DES INSTRUMENTS OPTIQUES. (FRA)	AVISO RADIACION LASER DE CLASE 1M VISIBLE Y/O INVISIBLE CUANDO ESTA ABIERTO. NO MIRAR DIRECTAMENTE CON INSTRUMENTAL OPTICO. (ESP)	WARNING SYNLIG OCH/ELLER OSYNLIG LASERSTRÅLNING, KLASS 1M, NÄR DENNA ÄR ÖPPNAD. BETRÄKTA EJ STRÅLEN MED OPTISKA INSTRUMENT. (SWE)	注意 ここを開くと有害 及び有害と不可知 のクラス1M レーザー放射が 出ます。 光学眼鏡で直接 見ないでください。 (JPN)	CAUTION VISIBLE AND/OR INVISIBLE CLASS I LASER RADIATION WHEN OPEN. DO NOT STARE INTO BEAM. FDA 21 CFR (EN3)
---	--	--	--	---	---

Warning:

If you need to operate the unit while driving, be sure to look ahead carefully or you may be involved in a traffic accident.



This symbol is only valid in the European Union.

Information for Users on Disposal of Old Equipment

This symbol indicates that the product with this symbol should not be disposed as general household waste at its end-of-life. If you wish to dispose of this product, please do so in accordance with applicable national legislation or other rules in your country and municipality. By disposing of this product correctly, you will help to conserve natural resources and will help prevent potential negative effects on the environment and human health.

How to reset your unit

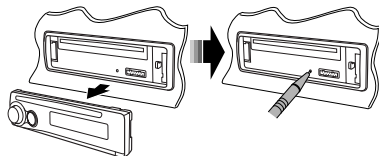

- Your preset adjustments will also be erased.

How to forcibly eject a disc

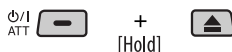

- Be careful not to drop the disc when it ejects.
- If this does not work, reset your unit.

How to use the M MODE button

If you press M MODE, the unit goes into functions mode, then the number buttons and ▲/▼ buttons work as different function buttons.

Ex.: When number button 2 works as MO (monaural) button.

To use these buttons for their original functions again after pressing M MODE, wait for 5 seconds without pressing any of these buttons until the functions mode is cleared or press M MODE again.

Detaching the control panel

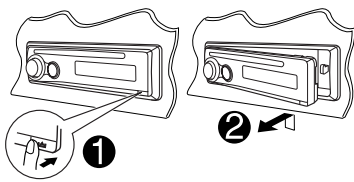

Attaching the control panel

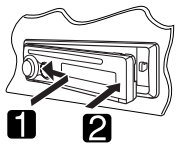

Caution on volume setting:

Discs produce very little noise compared with other sources. Lower the volume before playing a disc to avoid damaging the speakers by the sudden increase of the output level.

CONTENTS

Control panel	4
Remote controller — RM-RK50	5
Getting started	6
Basic operations	6
Radio operations	7
FM RDS operations	8
Searching for your favorite FM RDS programme	8
Disc operations	10
Playing a disc in the unit	10
iPod operations	12
Sound adjustments	14
General settings — PSM	15
External component operations	18
More about this unit	18
Maintenance	22
Troubleshooting	23
Specifications	25

For security reasons, a numbered ID card is provided with this unit, and the same ID number is imprinted on the unit's chassis. Keep the card in a safe place, as it will help the authorities to identify your unit if stolen.

For safety...

- Do not raise the volume level too much, as this will block outside sounds, making driving dangerous.
- Stop the car before performing any complicated operations.

Temperature inside the car...

If you have parked the car for a long time in hot or cold weather, wait until the temperature in the car becomes normal before operating the unit.

Control panel

Parts identification

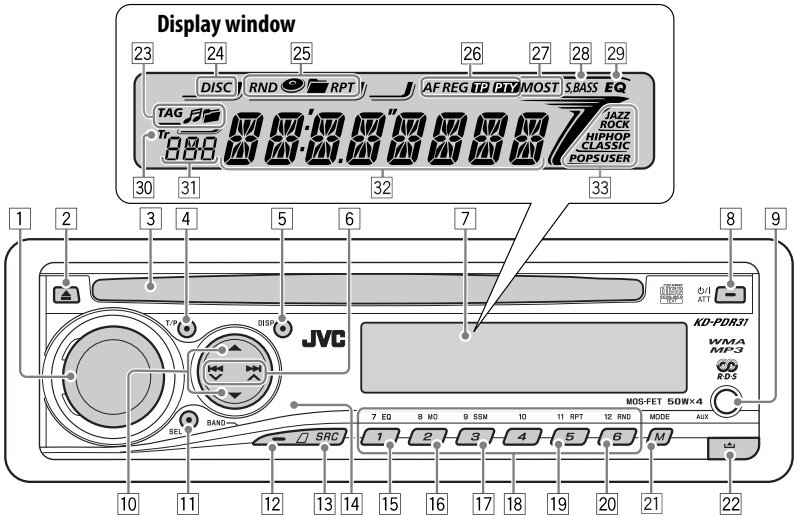

- | | | | |
|----|---|----|---|
| 1 | Control dial | 20 | RND (random) button |
| 2 | ▲ (eject) button | 21 | M MODE button |
| 3 | Loading slot | 22 | ▲ (control panel release) button |
| 4 | T/P (traffic programme/programme type) button | 23 | Disc information indicators—
TAG (Tag information), 🎵 (track/file), 📁 (folder) |
| 5 | DISP (display) button | 24 | DISC indicator |
| 6 | ◀◀ / ▶▶ / ▲ buttons | 25 | Playback mode / item indicators—RND (random),
📀 (disc), 📁 (folder), RPT (repeat) |
| 7 | Display window | 26 | RDS indicators—AF, REG, TP, PTY |
| 8 | ⏻ / ATT (standby/on attenuator) button | 27 | Tuner reception indicators—MO (monaural),
ST (stereo) |
| 9 | AUX (auxiliary) input jack | 28 | S.BASS (super bass) indicator |
| 10 | ▲ (up) / ▼ (down) buttons | 29 | EQ (equalizer) indicator |
| 11 | SEL (select) button | 30 | Tr (track) indicator |
| 12 | BAND button | 31 | Source display / Time countdown indicator |
| 13 | SRC (source) button | 32 | Main display |
| 14 | Remote sensor
<i>DO NOT expose the remote sensor to strong light
(direct sunlight or artificial lighting).</i> | 33 | Sound mode (iEQ: intelligent equalizer)
indicators—JAZZ, ROCK, HIP HOP, CLASSIC, POPS,
USER |
| 15 | EQ (equalizer) button | | |
| 16 | MO (monaural) button | | |
| 17 | SSM (Strong-station Sequential Memory) button | | |
| 18 | Number buttons | | |
| 19 | RPT (repeat) button | | |

Installing the lithium coin battery (CR2025)

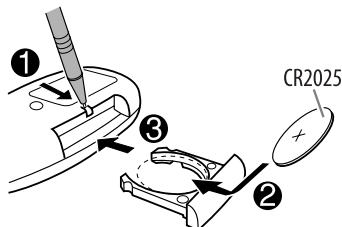

Aim the remote controller directly at the remote sensor on the unit. Make sure there is no obstacle in between.

Warning:

- Do not install any battery other than CR2025 or its equivalent; otherwise, it may explode.
- Do not leave the remote controller in a place (such as dashboards) exposed to direct sunlight for a long time; otherwise, it may explode.
- Store the battery in a place where children cannot reach to avoid risk of accident.
- To prevent the battery from over-heating, cracking, or starting a fire:
 - Do not recharge, short, disassemble, heat the battery, or dispose of it in a fire.
 - Do not leave the battery with other metallic materials.
 - Do not poke the battery with tweezers or similar tools.
 - Wrap the battery with tape and insulate when throwing away or saving it.

This unit is equipped with the steering wheel remote control function.

- See the Installation/Connection Manual (separate volume) for connection.

Main elements and features

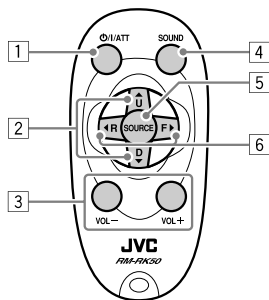

- 1** **⏻/ATT** (standby/on/attenuator) button
 - Turns the power on if pressed briefly or attenuates the sound when the power is on.
 - Turns the power off if pressed and held.
- 2** **▲ U** (up) / **D** (down) **▼** buttons
 - Changes the FM/AM bands with **▲ U**.
 - Changes the preset stations with **D ▼**.
 - Changes the folder of the MP3/WMA discs.
 - While listening to an Apple iPod:
 - Pauses or resumes playback with **D ▼**.
 - Enters the main menu with **▲ U**.
 (Now **▲ U/D ▼** / **◀ R/F ▶** work as the menu selecting buttons.)*
- 3** **VOL -** / **VOL +** buttons
 - Adjusts the volume level.
- 4** **SOUND** button
 - Selects the sound mode (iEQ: intelligent equalizer).
- 5** **SOURCE** button
 - Selects the source.
- 6** **◀ R** (reverse) / **F** (forward) **▶** buttons
 - Searches for stations if pressed briefly.
 - Fast-forwards or reverses the track if pressed and held.
 - Changes the tracks if pressed briefly.
 - While listening to an iPod (in menu selecting mode):
 - Selects an item if pressed briefly. (Then, press **D ▼** to confirm the selection.)
 - Skips 10 items at a time if pressed and held.

* **▲ U** : Returns to the previous menu.

D ▼ : Confirms the selection.

Getting started

Basic operations

1 Turn on the power.



2

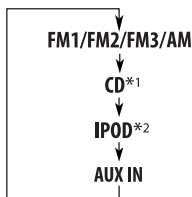

*1 You cannot select "CD" as the playback source if there is no disc in the unit.

*2 "NO IPOD" appears if iPod is not connected.

3 For FM/AM tuner



4 Adjust the volume.

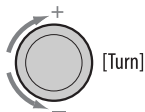

VOL 20

Volume level appears.

5 Adjust the sound as you want. (See pages 14 and 15.)

<p>To drop the volume in a moment (ATT)</p> <p>To restore the sound, press the button again.</p>	
<p>To turn off the power</p>	

Basic settings

- See also "General settings — PSM" on pages 15 – 17.

1



2

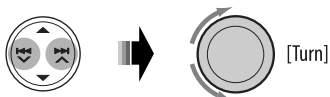

1 Canceling the display demonstrations

Select "DEMO," then "DEMO OFF."

2 Setting the clock

Select "CLOCK H" (hour), then adjust the hour. Select "CLOCK M" (minute), then adjust the minute.

Select "24H/12H," then "24H" (hour) or "12H" (hour).

3 Finish the procedure.



To check the current clock time while the power is turned off



Clock time is shown on the display for about 5 seconds. See also page 16.

Radio operations



Lights up when receiving an FM stereo broadcast with sufficient signal strength.

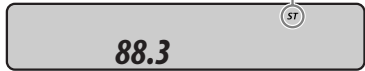

3 Start searching for a station.



When a station is received, searching stops. **To stop searching**, press the same button again.

To tune in to a station manually

In step 1 above...



2 Select a desired station frequency.



When an FM stereo broadcast is hard to receive



Lights up when monaural mode is activated.



Reception improves, but stereo effect will be lost.

To restore the stereo effect, repeat the same procedure. "MONO OFF" appears and the MO indicator goes off.

Storing stations in memory

You can preset six stations for each band.

FM station automatic presetting—SSM (Strong-station Sequential Memory)

1 Select the FM band (FM1 – FM3) you want to store into.





"SSM" flashes, then disappears when automatic presetting is over.

Local FM stations with the strongest signals are searched and stored automatically in the FM band.

Manual presetting

Ex.: Storing FM station of 92.5 MHz into preset number 4 of the FM1 band.

- 
- 
- 

Preset number flashes for a while.

Listening to a preset station

- 
- Select the preset station (1 – 6) you want.



or



To check the current clock time while listening to an FM (non-RDS) or AM station

- For FM RDS stations, see page 10.



Frequency ↔ Clock

FM RDS operations

What you can do with RDS

RDS (Radio Data System) allows FM stations to send an additional signal along with their regular programme signals.

By receiving the RDS data, this unit can do the following:

- Programme Type (PTY) Search (see the following)
- TA (Traffic Announcement) and PTY Standby Receptions (see pages 9 and 16)
- Tracing the same programme automatically —Network-Tracking Reception (see page 10)
- Programme Search (see pages 10 and 16)

Searching for your favorite FM RDS programme

You can tune in to a station broadcasting your favorite programme by searching for a PTY code.

- To store your favorite programme types, see page 9.

-  [Hold] The last selected PTY code appears.

- Select one of your favorite programme types.



or

- Select one of the PTY codes (see page 10).



3 Start searching for your favorite programme.



If there is a station broadcasting a programme of the same PTY code as you have selected, that station is tuned in.

Storing your favorite programme types

You can store six favorite programme types.

Preset programme types in the number buttons (1 to 6):

1	2	3	4	5	6
POP M	ROCK M	EASY M	CLASSICS	AFFAIRS	VARIED

- 1 Select a PTY code (see steps 1 to 3 on pages 8 and 9).
- 2 Select the preset number (1 – 6) you want to store into.



[Hold]



Ex.: When "ROCK M" is selected

- 3 Repeat steps 1 and 2 to store other PTY codes into other preset numbers.
- 4 Finish the procedure.



[Hold]

Using the standby receptions

TA Standby Reception

TA Standby Reception allows the unit to switch temporarily to Traffic Announcement (TA) from any source other than AM.

The volume changes to the preset TA volume level if the current level is lower than the preset level (see page 16).

To activate TA Standby Reception



The TP (Traffic Programme) indicator either lights up or flashes.

- If the TP indicator lights up, TA Standby Reception is activated.
- If the TP indicator flashes, TA Standby Reception is not yet activated. (This occurs when you are listening to an FM station without the RDS signals required for TA Standby Reception.)

To activate TA Standby Reception, tune in to another station providing these signals. The TP indicator will stop flashing and remain lit.

To deactivate the TA Standby Reception



The TP indicator goes off.

PTY Standby Reception

PTY Standby Reception allows the unit to switch temporarily to your favorite PTY programme from any source other than AM.

To activate and select your favorite PTY code for PTY Standby Reception, see page 16.

- The PTY indicator either lights up or flashes.
 - If the PTY indicator lights up, PTY Standby Reception is activated.
 - If the PTY indicator flashes, PTY Standby Reception is not yet activated.
- To activate PTY Standby Reception, tune in to another station providing these signals. The PTY indicator will stop flashing and remain lit.

Continued on the next page

To deactivate the **PTY Standby Reception**, select "OFF" for the PTY code (see page 16). The PTY indicator goes off.

Tracing the same programme— Network-Tracking Reception

When driving in an area where FM reception is not sufficient enough, this unit automatically tunes in to another FM RDS station of the same network, possibly broadcasting the same programme with stronger signals (see the illustration below).

When shipped from the factory, Network-Tracking Reception is activated.

To change the **Network-Tracking Reception setting**, see "AF-REG" on page 16.

Programme A broadcasting on different frequency areas (01 – 05)

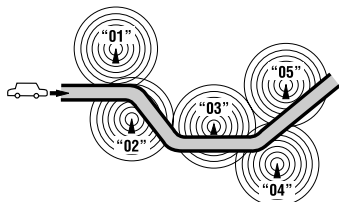

Automatic station selection— Programme Search

Usually when you press the number buttons, the preset station is tuned in.

If the signals from the FM RDS preset station are not sufficient for good reception, this unit, using the AF data, tunes in to another frequency broadcasting the same programme as the original preset station is broadcasting.

- The unit takes some time to tune in to another station using programme search.
- See also page 16.

To check the current clock time while listening to an FM RDS station



Station name (PS) → Station Frequency → Programme type (PTY) → Clock → (back to the beginning)

PTY codes

NEWS, AFFAIRS, INFO, SPORT, EDUCATE, DRAMA, CULTURE, SCIENCE, VARIED, POP M (music), ROCK M (music), EASY M (music), LIGHT M (music), CLASSICS, OTHER M (music), WEATHER, FINANCE, CHILDREN, SOCIAL, RELIGION, PHONE IN, TRAVEL, LEISURE, JAZZ, COUNTRY, NATION M (music), OLDIES, FOLK M (music), DOCUMENT

Disc operations

Playing a disc in the unit

All tracks will be played repeatedly until you change the source or eject the disc.

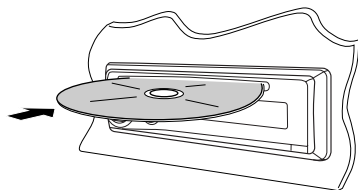

To stop play and eject the disc



- Press SRC to listen to another playback source.

To fast-forward or reverse the track



To go to the next or previous tracks



To go to the next or previous folders (only for MP3 or WMA discs)



To locate a particular track (for CD) or folder (for MP3 or WMA discs) directly

To select a number from 01 – 06:



To select a number from 07 – 12:



[Hold]

- To use direct folder access on MP3/WMA discs, it is required that folders are assigned with 2-digit numbers at the beginning of their folder names—01, 02, 03, and so on.

To select a particular track in a folder (for MP3 or WMA disc):



Other main functions

■ Skipping tracks quickly during play

- For MP3 or WMA discs, you can skip tracks within the same folder.

Ex.: To select track 32 while playing tracks whose number is a single digit (1 to 9)

1 MODE
M

2 Track 1 to 9 → Track 10
..... 30 ← 20

Each time you press the button, you can skip 10 tracks.

- After the last track, the first track will be selected and vice versa.

3 Track 31 → 32 →

■ Prohibiting disc ejection

You can lock a disc in the loading slot.



To cancel the prohibition, repeat the same procedure.

Changing the display information



While playing an audio CD or a CD Text



While playing an MP3 or a WMA track

- When "TAG DISP" is set to "TAG ON" (see page 17)

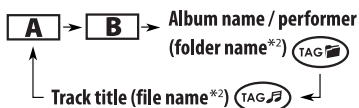

- When "TAG DISP" is set to "TAG OFF"



- A** : Elapsed playing time with the current track number
- B** : Clock with the current track number
- : Corresponding indicator lights up on the display

*1 If the current disc is an audio CD, "NO NAME" appears.

*2 If an MP3/WMA file does not have Tag information, folder name and file name appear. In this case, the TAG indicator will not light up.

Selecting the playback modes

You can use only one of the following playback modes at a time.

1 **MODE**

2 Select your desired playback mode.

■ Repeat play 11 RPT

Mode **Plays repeatedly**

TRK RPT : The current track. (RPT)

FLDR RPT* : All tracks of the current folder.



RPT OFF : Cancels.

■ Random play 12 RND

Mode **Plays at random**

FLDR RND* : All tracks of the current folder, then tracks of the next folder and so on.



DISC RND : All tracks of the current disc.



RND OFF : Cancels.

* Only while playing an MP3 or a WMA disc.

○ : Corresponding indicator lights up on the display

iPod operations

You can play songs from an Apple iPod through this unit by connecting it with the supplied connection cable for iPod.

- Disconnecting the iPod will stop playback. Press SRC to listen to another playback source.

- For connection, see Installation/Connection Manual (separate volume).
- For details, refer also to the manual supplied with your iPod.

1 Connect an iPod.

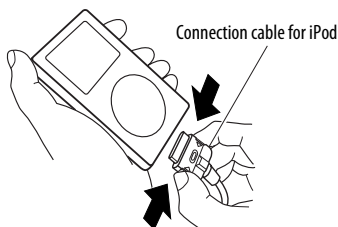

If an iPod has been connected...



Playback starts automatically from where it has been paused previously.

2 Adjust the volume.

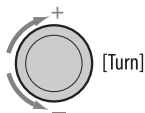

3 Adjust the sound as you want. (See pages 14 and 15.)

Caution:

- Avoid using the iPod if it might hinder your safety driving.
- Make sure all important data has been backed up to avoid losing the data.

To pause playback



To resume playback, press the button again.

To fast-forward or reverse the track



To go to the next or previous tracks



Selecting a track from the menu

1 Enter the main menu.



Now the \blacktriangle / \blacktriangledown / \blacktriangleleft / \blacktriangleright / \blacktriangleleft / \blacktriangleright / \blacktriangleleft / \blacktriangleright / \blacktriangleleft / \blacktriangleright buttons work as the menu selecting buttons*.

2 Select the desired menu.



PLAYLIST \leftrightarrow ARTISTS \leftrightarrow ALBUMS \leftrightarrow
SONGS \leftrightarrow GENRES \leftrightarrow COMPOSER \leftrightarrow
(back to the beginning)

3 Confirm the selection.



To move back to the previous menu, press \blacktriangle .

- If a track is selected, playback starts automatically.
- If the selected item has another layer, you will enter the layer. Repeat steps 2 and 3 until the desired track is played (see page 21).
- Holding \blacktriangleleft / \blacktriangleright / \blacktriangleleft / \blacktriangleright / \blacktriangleleft / \blacktriangleright / \blacktriangleleft / \blacktriangleright can skip 10 items at a time.

* The menu selecting mode will be canceled:
– If no operations are done for about 5 seconds.
– When you confirm the selection of a track.

Selecting the playback modes

1 MODE



2 Select your desired playback mode.

■ Repeat play

11 RPT



Mode **Playback functions (as on iPod)**

ONE RPT : Same as "Repeat One." 

ALL RPT : Same as "Repeat All." 



RPT OFF : Cancels.

■ Random play

12 RND



Mode **Playback functions (as on iPod)**

ALBM RND* : Same as "Shuffle Albums."  

SONG RND : Same as "Shuffle Songs." 

RND OFF : Cancels.

* Functions only if you select "ALL" in "ALBUMS" of the main "MENU."

 : Corresponding indicator lights up on the display

To check other information while listening to an iPod

DISP 

Sound adjustments

You can select a preset sound mode suitable to the music genre (iEQ: intelligent equalizer).

1 MODE



2  

Preset values	Indication (For)			
	BAS*1	MID*2	TRE*3	S.BS*4
USER (Flat sound)	00	00	00	OFF
ROCK (Rock or disco music)	+03	00	+02	ON
CLASSIC (Classical music)	+01	00	+03	OFF
POPS (Light music)	+02	+01	+02	OFF
HIP HOP (Funk or rap music)	+04	-02	+01	ON
JAZZ (Jazz music)	+03	00	+03	OFF

*1 : Bass; *2 : Mid-range; *3 : Treble; *4 : Super bass

Adjusting the sound

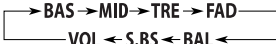
You can adjust the sound characteristics to your preference.

1  

2  [Turn]

Indication, [Range]**BAS** *¹ (bass), [-06 to +06]

Adjust the bass.

MID *¹ (mid-range), [-06 to +06]

Adjust the mid-range frequencies sound level.

TRE *¹ (treble), [-06 to +06]

Adjust the treble.

FAD *² (fader), [R06 to F06]

Adjust the front and rear speaker balance.

BAL (balance), [L06 to R06]

Adjust the left and right speaker balance.

S.BS *¹ (super bass), [S.BS ON or S.BS OFF],[01 to 05, initial: 03] *³

Maintain the richness and fullness of the bass sound regardless of how low you set the volume.

VOL (volume), [00 to 30 or 50 *⁴]

Adjust the volume.

*¹ When you adjust the bass, mid-range, treble, or super bass, the adjustment you have made is stored for the currently selected sound mode (iEQ) including "USER."

*² If you are using a two-speaker system, set the fader level to "00."

*³ Range adjustment for super bass is adjustable only when it is set to "S.BS ON."

*⁴ Depending on the amplifier gain control setting. (See page 17 for details.)

General settings — PSM

You can change PSM (Preferred Setting Mode) items listed in the table that follows.

1  [Hold]

2 Select a PSM item.



3 Adjust the PSM item selected.

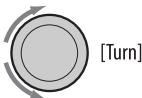

4 Repeat steps 2 and 3 to adjust other PSM items if necessary.

5 Finish the procedure.



Continued on the next page

Indications	Item (__ : Initial)	Setting, [reference page]
DEMO Display demonstration	<ul style="list-style-type: none"> • DEMO ON • DEMO OFF 	<ul style="list-style-type: none"> : Display demonstration will be activated automatically if no operation is done for about 20 seconds, [6]. : Cancels.
CLK DISP *1 Clock display	<ul style="list-style-type: none"> • ON • OFF 	<ul style="list-style-type: none"> : Clock time is shown on the display at all times when the power is turned off. : Cancels; pressing DISP will show the clock time for about 5 seconds when the power is turned off, [6].
CLOCK H Hour adjustment	0 – 23 (1 – 12)	[Initial: 0 (0:00)], [6]
CLOCK M Minute adjustment	00 – 59	[Initial: 00 (0:00)], [6]
24H/12H Time display mode	<ul style="list-style-type: none"> • 24H • 12H 	: See also page 6 for setting.
CLK ADJ *2 Clock adjustment	<ul style="list-style-type: none"> • AUTO • OFF 	<ul style="list-style-type: none"> : The built-in clock is automatically adjusted using the CT (clock time) data in the RDS signal. : Cancels.
AF-REG *2 Alternative frequency/ regionalization reception	<ul style="list-style-type: none"> • AF • AF REG • OFF 	<ul style="list-style-type: none"> : When the currently received signals become weak, the unit switches to another station (the programme may differ from the one currently received), [10]. <ul style="list-style-type: none"> • The AF indicator lights up. : When the currently received signals become weak, the unit switches to another station broadcasting the same programme. <ul style="list-style-type: none"> • The AF and REG indicators light up. : Cancels.
PTY-STBY *2 PTY standby	OFF, PTY codes	Activates PTY Standby Reception with one of the PTY codes, [9, 10].
TA VOL *2 Traffic announcement volume	VOL 00 – VOL 30 or 50 *3	[Initial: VOL 15]
P-SEARCH *2 Programme search	<ul style="list-style-type: none"> • ON • OFF 	<ul style="list-style-type: none"> : Activates Programme Search, [10]. : Cancels.

*1 If the power supply is not interrupted by turning off the ignition key of your car, it is recommended to select "OFF" to save the car's battery.

*2 Only for FM RDS stations.

*3 Depends on the amplifier gain control.

Indications	Item (__: Initial)	Setting, [reference page]
DIMMER Dimmer	<ul style="list-style-type: none"> • ON • OFF 	<ul style="list-style-type: none"> : Activates dimmer. : Cancels.
TEL Telephone muting	<ul style="list-style-type: none"> • MUTING 1/ MUTING 2 • OFF 	<ul style="list-style-type: none"> : Select either one which mutes the sounds while using a cellular phone. : Cancels.
SCROLL *4 Scroll	<ul style="list-style-type: none"> • ONCE • AUTO • OFF 	<ul style="list-style-type: none"> : Scrolls the track information once. : Repeats scrolling (at 5-second intervals). : Cancels. • Pressing DISP for more than one second can scroll the display regardless of the setting.
AUX ADJ Auxiliary input level adjustment	A.ADJ 00 – A.ADJ 05	: Adjust the auxiliary input level to avoid the sudden increase of the output level when changing the source from external component connected to the AUX input jack on the control panel.
TAG DISP Tag display	<ul style="list-style-type: none"> • TAG ON • TAG OFF 	<ul style="list-style-type: none"> : Shows the Tag information while playing MP3/WMA tracks, [12]. : Cancels.
AMP GAIN Amplifier gain control	<ul style="list-style-type: none"> • LOW PWR • HIGH PWR 	<ul style="list-style-type: none"> : VOL 00 – VOL 30 (Select this if the maximum power of the speaker is less than 50 W to prevent damaging the speaker.) : VOL 00 – VOL 50
IF BAND Intermediate frequency band	<ul style="list-style-type: none"> • AUTO • WIDE 	<ul style="list-style-type: none"> : Increases the tuner selectivity to reduce interference noises between close stations. (Stereo effect may be lost.) : Subject to interference noises from adjacent stations, but sound quality will not be degraded and the stereo effect will remain.

*4 Some characters or symbols will not be shown correctly (or will be blanked) on the display.

External component operations

You can connect an external component to the AUX (auxiliary) input jack on the control panel.

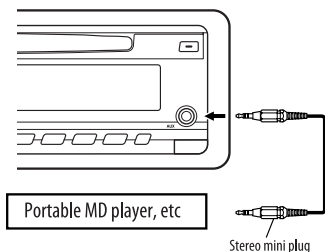

2 Turn on the connected component and start playing the source.

3 Adjust the volume.

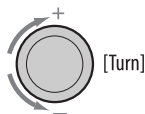

4 Adjust the sound as you want. (See pages 14 and 15.)

To check other information while listening to an external component



AUX IN ↔ Clock

More about this unit

Basic operations

Turning on the power

- By pressing SRC on the unit, you can also turn on the power. If the source is ready, playback also starts.

Turning off the power

- If you turn off the power while listening to a track, playback starts from where it has been stopped previously, next time you turn on the power.

General

- If you change the source while listening to a disc or an iPod, playback stops. Next time you select "CD" or "IPOD" as the playback source, playback starts from where it has been stopped/paused previously.
- After ejecting a disc or disconnecting an iPod, "NO DISC" or "NO IPOD" appears and you cannot operate some of the buttons. Insert another disc, reconnect an iPod, or press SRC to select another playback source.

Tuner operations

Storing stations in memory

- During SSM search...
 - All previously stored stations are erased and stations are stored newly.
 - Received stations are preset in No. 1 (lowest frequency) to No. 6 (highest frequency).
 - When SSM is over, the station stored in No. 1 will be automatically tuned in.
- When storing a station manually, the previously preset station is erased when a new station is stored in the same preset number.

FM RDS operations

- Network-Tracking Reception requires two types of RDS signals—PI (Programme Identification) and AF (Alternative Frequency) to work correctly. Without receiving these data correctly, Network-Tracking Reception will not operate correctly.

- If a Traffic Announcement is received by TA Standby Reception, the volume level automatically changes to the preset level (TA VOL) if the current level is lower than the preset level.
- When Alternative Frequency Reception is activated (with AF selected), Network-Tracking Reception is also activated automatically. (See page 16.)
- If you want to know more about RDS, visit <<http://www.rds.org.uk>>.
- The pickup lens inside the unit is dirty.
- CD-R/CD-RW on which the files are written with “Packet Write” method.
- There are improper recording conditions (missing data, etc.) or media conditions (stained, scratched, warped, etc.).
- CD-RWs may require a longer readout time since the reflectance of CD-RWs is lower than that of regular CDs.
- Do not use the following CD-Rs or CD-RWs:
 - Discs with stickers, labels, or a protective seal stuck to the surface.
 - Discs on which labels can be directly printed by an ink jet printer.

Using these discs under high temperatures or high humidities may cause malfunctions or damage to the unit.

Disc operations

Caution for DualDisc playback

- The Non-DVD side of a “DualDisc” does not comply with the “Compact Disc Digital Audio” standard. Therefore, the use of Non-DVD side of a DualDisc on this product may not be recommended.

General

- This unit has been designed to reproduce CDs/CD Texts, and CD-Rs (Recordable)/CD-RWs (Rewritable) in audio CD (CD-DA), MP3 and WMA formats.
- When a disc is inserted upside down, “PLEASE” and “EJECT” appear alternately on the display. Press **▲** to eject the disc.
- MP3 and WMA “tracks” (words “file” and “track” are used interchangeably) are recorded in “folders.”
- While fast-forwarding or reversing on an MP3 or WMA disc, you can only hear intermittent sounds.

Playing a CD-R or CD-RW

- Use only “finalized” CD-Rs or CD-RWs.
- This unit can play back only files of the same type which are first detected if a disc includes both audio CD (CD-DA) files and MP3/WMA files.
- This unit can play back multi-session discs; however, unclosed sessions will be skipped while playing.
- Some CD-Rs or CD-RWs may not play back on this unit because of their disc characteristics, or for the following reasons:
 - Discs are dirty or scratched.
 - Moisture condensation occurs on the lens inside the unit.

Playing an MP3/WMA disc

- This unit can play back MP3/WMA files with the extension code <.mp3> or <.wma> (regardless of the letter case—upper/lower).
- This unit can show the names of albums, artists (performer), and Tag (Version 1.0, 1.1, 2.2, 2.3, or 2.4) for MP3 files and for WMA files.
- This unit can display only one-byte characters. No other characters can be correctly displayed.
- This unit can play back MP3/WMA files meeting the conditions below:
 - Bit rate: 8 kbps — 320 kbps
 - Sampling frequency:
 - 48 kHz, 44.1 kHz, 32 kHz (for MPEG-1)
 - 24 kHz, 22.05 kHz, 16 kHz (for MPEG-2)
 - Disc format: ISO 9660 Level 1/ Level 2, Romeo, Joliet, Windows long file name
- The maximum number of characters for file/folder names vary among the disc format used (includes 4 extension characters—<.mp3> or <.wma>).
 - ISO 9660 Level 1: up to 12 characters
 - ISO 9660 Level 2: up to 31 characters
 - Romeo: up to 128 characters
 - Joliet: up to 64 characters
 - Windows long file name: up to 128 characters

Continued on the next page

- This unit can recognize a total of 512 files, of 200 folders, and of 8 hierarchies.
 - This unit can play back files recorded in VBR (variable bit rate).
Files recorded in VBR have a discrepancy in elapsed time display, and do not show the actual elapsed time. Especially, after performing the search function, this difference becomes noticeable.
 - This unit cannot play back the following files:
 - MP3 files encoded with MP3i and MP3 PRO format.
 - MP3 files encoded in an inappropriate format.
 - MP3 files encoded with Layer 1/2.
 - WMA files encoded with lossless, professional, and voice format.
 - WMA files which are not based upon Windows Media® Audio.
 - WMA files copy-protected with DRM.
 - Files which have the data such as AIFF, ATRAC3, etc.
 - The search function works but search speed is not constant.
- If your iPod software version is older than those mentioned above, you may not be able to control the iPod properly. Update your iPod to the latest software version before using it with this unit.
 - You can check the software version of your iPod from “About” in the “Setting” menu of the iPod.
 - For details about updating your iPod, visit <<http://www.apple.com>>.
 - When you turn on this unit, the iPod is charged through this unit.
 - While the iPod is connected, all operations from the iPod are disabled. Perform all operations from this unit.
 - While connecting an iPod with Video:
 - No video shows on the iPod’s display or the external monitor (only the audio part is available).
 - It is not possible to browse video files on the “Video” menu. (If you connect the iPod during playback or pausing of a video file, resuming playback will not work.)
 - iPod shuffle is not controllable.
 - You can control the iPod from this unit when “JVC” or “√” appears on the iPod display.
 - The songs order displayed on the selecting menu of this unit may differ from the iPod.
 - If playback is stopped, select a track from the selecting menu or press ▼.
 - The text information may not be displayed correctly.
 - Some characters such as accented letters cannot be shown correctly on the display.
 - Depends on the condition of communication between the iPod and the unit.
 - If the text information includes more than 8 characters, it scrolls on the display. This unit can display up to 40 characters.

Ejecting a disc

- If the ejected disc is not removed within 15 seconds, the disc is automatically inserted again into the loading slot to protect it from dust. Playback starts automatically.

iPod operations

Controllable iPod	Software version
iPod with dock connector (3rd Generation)	2.3 or later
iPod with Click Wheel (4th Generation)	3.1 or later
iPod mini	1.4 or later
iPod photo	1.2 or later
iPod nano	1.0 or later
iPod with Video (5th Generation)	1.0 or later

General settings—PSM

- If you change the “AMP GAIN” setting from “HIGH PWR” to “LOW PWR” while the volume level is set higher than “VOL 30,” the unit automatically changes the volume level to “VOL 30.”

Hierarchical structure of file searching when an iPod is connected

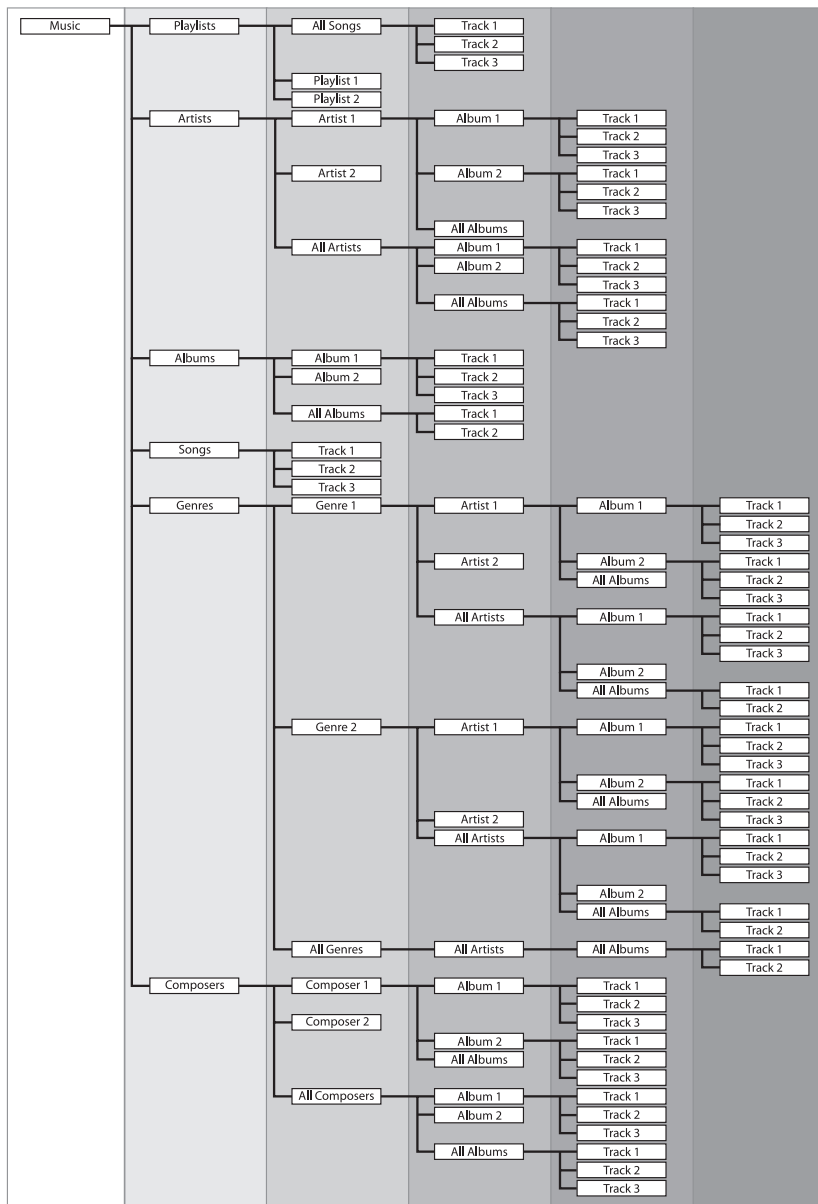

Maintenance

How to clean the connectors

Frequent detachment will deteriorate the connectors. To minimize this possibility, periodically wipe the connectors with a cotton swab or cloth moistened with alcohol, being careful not to damage the connectors.

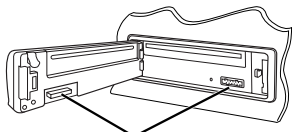

Connector

Moisture condensation

Moisture may condense on the lens inside the unit in the following cases:

- After starting the heater in the car.
- If it becomes very humid inside the car.

Should this occur, the unit may malfunction. In this case, eject the disc and leave the unit turned on for a few hours until the moisture evaporates.

How to handle discs

When removing a disc from its case, press down the center holder of the case and lift the disc out, holding it by the edges.

- Always hold the disc by the edges.
- Do not touch its recording surface.

When storing a disc into its case, gently insert the disc around the center holder (with the printed surface facing up).

- Make sure to store discs into the cases after use.

Center holder



To keep discs clean

A dirty disc may not play correctly. If a disc does become dirty, wipe it with a soft cloth in a straight line from center to edge.



- Do not use any solvent (for example, conventional record cleaner, spray, thinner, benzene, etc.) to clean discs.

To play new discs

New discs may have some rough spots around the inner and outer edges. If such a disc is used, this unit may reject the disc.



To remove these rough spots, rub the edges with a pencil or ball-point pen, etc.

Do not use the following discs:



Troubleshooting

What appears to be trouble is not always serious. Check the following points before calling a service center.

	Symptoms	Remedies/Causes
General	<ul style="list-style-type: none"> • Sound cannot be heard from the speakers. 	<ul style="list-style-type: none"> • Adjust the volume to the optimum level. • Check the cords and connections.
	<ul style="list-style-type: none"> • The unit does not work at all. 	Reset the unit (see page 2).
FM/AM	<ul style="list-style-type: none"> • SSM automatic presetting does not work. 	Store stations manually.
	<ul style="list-style-type: none"> • Static noise while listening to the radio. 	Connect the aerial firmly.
Disc playback	<ul style="list-style-type: none"> • Disc cannot be played back. 	Insert the disc correctly.
	<ul style="list-style-type: none"> • CD-R/CD-RW cannot be played back. • Tracks on the CD-R/CD-RW cannot be skipped. 	<ul style="list-style-type: none"> • Insert a finalized CD-R/CD-RW. • Finalize the CD-R/CD-RW with the component which you used for recording.
	<ul style="list-style-type: none"> • Disc can neither be played back nor ejected. 	<ul style="list-style-type: none"> • Unlock the disc (see page 11). • Eject the disc forcibly (see page 2).
	<ul style="list-style-type: none"> • Disc sound is sometimes interrupted. 	<ul style="list-style-type: none"> • Stop playback while driving on rough roads. • Change the disc. • Check the cords and connections.
	<ul style="list-style-type: none"> • "NO DISC" appears on the display. 	Insert a playable disc into the loading slot.
MP3/WMA playback	<ul style="list-style-type: none"> • Disc cannot be played back. 	<ul style="list-style-type: none"> • Use a disc with MP3/WMA tracks recorded in the format compliant with ISO 9660 Level 1, Level 2, Romeo, or Joliet. • Add the extension code <.mp3> or <.wma> to the file names.
	<ul style="list-style-type: none"> • Noise is generated. 	Skip to another track or change the disc. (Do not add the extension code <.mp3> or <.wma> to non-MP3 or WMA tracks.)
	<ul style="list-style-type: none"> • A longer readout time is required ("CHECK" keeps flashing on the display). 	Do not use too many hierarchies and folders.

Continued on the next page

	Symptoms	Remedies/Causes
MP3/WMA playback	• Tracks do not play back in the order you have intended them to play.	Playback order is determined when the files are recorded.
	• Elapsed playing time is not correct.	This sometimes occurs during play. This is caused by how the tracks are recorded on the disc.
	• "PLEASE" and "EJECT" appear alternately on the display.	Insert a disc that contains MP3/WMA tracks.
	• Correct characters are not displayed (e.g. album name).	This unit can only display letters (upper case), numbers, and a limited number of symbols.
iPod playback	• The iPod does not turn on or does not work.	<ul style="list-style-type: none"> • Check the connecting cable and its connection. • Update the firmware version. • Charge the battery.
	• The sound is distorted.	Deactivate the equalizer either on the unit or the iPod.
	• "NO IPOD" appears on the display.	<ul style="list-style-type: none"> • Check the connecting cable and its connection. • Charge the battery.
	• Playback stops.	The headphones are disconnected during playback. Turn off the unit's power and turn it on again.
	• No sound can be heard when connecting an iPod nano.	<ul style="list-style-type: none"> • Disconnect the headphones from the iPod nano. • Update the firmware version of the iPod nano.
	• "NO FILES" appears on the display.	No tracks are stored. Import tracks to the iPod.
	• "RESET 1" – "RESET 7" appears on the display.	Reconnect the iPod.
	• "RESET 8" appears on the display.	Check the connecting cable and its connection.
	• The iPod's controls do not work after disconnecting from this unit.	Reset the iPod.

- Microsoft and Windows Media are either registered trademarks or trademarks of Microsoft Corporation in the United States and/or other countries.
- iPod is a trademark of Apple Computer, Inc., registered in the U.S. and other countries.

Specifications

AUDIO AMPLIFIER SECTION

Maximum Power Output:	
Front/Rear:	50 W per channel
Continuous Power Output (RMS):	
Front/Rear:	19 W per channel into 4 Ω , 40 Hz to 20 000 Hz at no more than 0.8% total harmonic distortion.
Load Impedance:	4 Ω (4 Ω to 8 Ω allowance)
Tone Control Range:	
Bass/Mid-range/ Treble:	± 12 dB at 60 Hz/1 kHz/ 7.5 kHz
Frequency Response:	40 Hz to 20 000 Hz
Signal-to-Noise Ratio:	70 dB
Line-Out Level Impedance:	2.5 V/20 k Ω load (full scale)
Output Impedance:	1 k Ω
Other Terminal:	AUX (auxiliary) input jack, iPod jack, Steering wheel remote input

TUNER SECTION

Frequency Range:	
FM:	87.5 MHz to 108.0 MHz
AM:	MW: 522 kHz to 1 620 kHz LW: 144 kHz to 279 kHz
FM Tuner	
Usable Sensitivity:	11.3 dBf (1.0 μ V/75 Ω)
50 dB Quieting Sensitivity:	16.3 dBf (1.8 μ V/75 Ω)
Alternate Channel Selectivity (400 kHz):	65 dB
Frequency Response:	40 Hz to 15 000 Hz
Stereo Separation:	30 dB
MW Tuner	
Sensitivity/Selectivity:	20 μ V/35 dB
LW Tuner	
Sensitivity:	50 μ V

CD PLAYER SECTION

Type:	Compact disc player
Signal Detection System:	Non-contact optical pickup (semiconductor laser)
Number of Channels:	2 channels (stereo)
Frequency Response:	5 Hz to 20 000 Hz
Dynamic Range:	96 dB
Signal-to-Noise Ratio:	98 dB
Wow and Flutter:	Less than measurable limit
MP3 Decoding Format: (MPEG1/2 Audio Layer 3)	
Max. Bit Rate:	320 kbps
WMA (Windows Media [®] Audio) Decoding Format:	
Max. Bit Rate:	192 kbps

GENERAL

Power Requirement:	
Operating Voltage:	DC 14.4 V (11 V to 16 V allowance)
Grounding System:	Negative ground
Allowable Operating Temperature:	0°C to +40°C
Dimensions (W \times H \times D): (approx.)	
Installation Size:	182 mm \times 52 mm \times 150 mm
Panel Size:	187 mm \times 58 mm \times 13 mm
Mass:	1.3 kg (excluding accessories)

Design and specifications are subject to change without notice.

**Having TROUBLE with operation?
Please reset your unit**

Refer to page of How to reset your unit

**Haben Sie PROBLEME mit dem Betrieb?
Bitte setzen Sie Ihr Gerät zurück**
Siehe Seite Zurücksetzen des Geräts

Затруднения при эксплуатации?

Пожалуйста, перезагрузите Ваше устройство

Для получения информации о перезагрузке Вашего устройства обратитесь на соответствующую страницу

Dear Customer,

This apparatus is in conformance with the valid European directives and standards regarding electromagnetic compatibility and electrical safety.

European representative of Victor Company of Japan, Limited is:

JVC Technology Centre Europe GmbH
Postfach 10 05 52
61145 Friedberg
Germany

Sehr geehrter Kunde, sehr geehrte Kundin,
dieses Gerät stimmt mit den gültigen europäischen Richtlinien und Normen bezüglich elektromagnetischer Verträglichkeit und elektrischer Sicherheit überein.

Die europäische Vertretung für die Victor Company of Japan, Limited ist:

JVC Technology Centre Europe GmbH
Postfach 10 05 52
61145 Friedberg
Deutschland

Уважаемый клиент.

Данное устройство соответствует действительным Европейским директивам и стандартам по электромагнитной совместимости и электрической безопасности.

Представительство компании Victor Company of Japan, Limited в Европе:

JVC Technology Centre Europe GmbH
Postfach 10 05 52
61145 Friedberg
Германия

JVC



EN, GE, RU

© 2007 Victor Company of Japan, Limited

0107DTSMDTJEIN

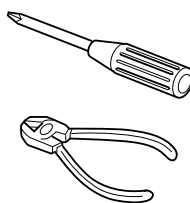

ENGLISH

This unit is designed to operate on **12 V DC, NEGATIVE ground electrical systems**. If your vehicle does not have this system, a voltage inverter is required, which can be purchased at JVC IN-CAR ENTERTAINMENT dealers.

WARNINGS

To prevent short circuits, we recommend that you disconnect the battery's negative terminal and make all electrical connections before installing the unit.

- **Be sure to ground this unit to the car's chassis again after installation.**

Notes:

- Replace the fuse with one of the specified rating. If the fuse blows frequently, consult your JVC IN-CAR ENTERTAINMENT dealer.
- It is recommended to connect to the speakers with maximum power of more than 50 W (both at the rear and at the front, with an impedance of **4 Ω to 8 Ω**). If the maximum power is less than 50 W, change "AMP GAIN" setting to prevent the speakers from being damaged (see page 17 of the INSTRUCTIONS).
- To prevent short-circuit, cover the terminals of the UNUSED leads with insulating tape.
- The heat sink becomes very hot after use. Be careful not to touch it when removing this unit.

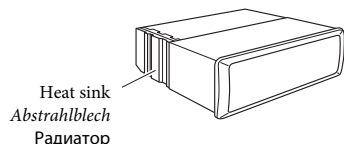

DEUTSCH

Dieses Gerät ist für einen Betrieb in **elektrischen Anlagen mit 12 V Gleichstrom und (-) Erdung ausgelegt**. Verfügt Ihr Fahrzeug nicht über diese Anlage, ist ein Spannungsinverter erforderlich, der bei JVC Autoradiohändler erworben werden kann.

WARNUNGEN

Zur Vermeidung von Kurzschlüssen empfehlen wir, daß Sie den **negativen Batterieanschluß abtrennen und alle elektrischen Anschlüsse herstellen, bevor das Gerät eingebaut wird**.

- **Sicherstellen, daß das Gerät nach dem Einbau a Chassis des Fahrzeugs geerdet wird.**

Hinweise:

- Die Sicherung mit einer der entsprechenden Nennleistung ersetzen. Brennt die Sicherung häufig durch, wenden Sie sich an ihren JVC Autoradiohändler.
- Es wird empfohlen, Lautsprecher mit einer Maximalleistung von mehr als 50 W anzuschließen (sowohl hinten als auch vorne, mit einer Impedanz von **4 Ω bis 8 Ω**). Wenn die Maximalleistung weniger als 50 W beträgt, stellen Sie „AMP GAIN“ anders ein, um Schäden an den Lautsprechern zu vermeiden (siehe Seite 17 der BEDIENUNGSANLEITUNG).
- Zur Vermeidung eines Kurzschlusses die Anschlussklemmen der **NICHT VERWENDETEN** Leitungen mit Isolierklebeband umwickeln.
- Das Abstrahlblech wird nach dem Gebrauch sehr heiß. Beim Ausbau des Geräts darauf achten, das Abstrahlblech nicht zu berühren.

РУССКИЙ

Это устройство разработано для эксплуатации на **12 В постоянного напряжения с минусом на массе**. Если Ваш автомобиль не имеет этой системы, требуется инвертор напряжения, который может быть приобретен у дилера автомобильного специалиста JVC.

ПРЕДУПРЕЖДЕНИЯ

Для предотвращения коротких замыканий мы рекомендуем Вам отсоединить отрицательный разъем аккумулятора и осуществить все подключения перед установкой устройства.

- **После установки обязательно заземлите данное устройство на шасси автомобиля.**

Примечания:

- Заменяйте предохранитель другим предохранителем указанного класса. Если предохранитель сгорает слишком часто, обратитесь к дилеру автомобильного специалиста JVC.
- Рекомендуется подключать динамики с максимальной мощностью более 50 Вт (к задней и передней панели устройства, с полным сопротивлением от **4 Ω до 8 Ω**). Если максимальная мощность динамиков менее 50 Вт, перейдите в режим "AMP GAIN", чтобы предотвратить их повреждение (см. ИНСТРУКЦИИ ПО ЭКСПЛУАТАЦИИ на стр. 17).
- Для предотвращения короткого замыкания заклейте НЕИСПОЛЬЗУЕМЫЕ концы изолирующей лентой.
- Радиатор во время использования сильно нагревается. Старайтесь его не трогать во время удаления устройства.

PRECAUTIONS on power supply and speaker connections:

- **DO NOT connect the speaker leads of the power cord to the car battery; otherwise, the unit will be seriously damaged.**
- BEFORE connecting the speaker leads of the power cord to the speakers, check the speaker wiring in your car.

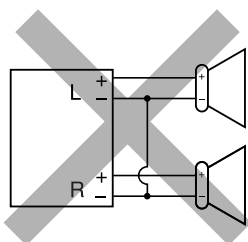

VORSICHTSMASSREGELN beim Anschließen der Stromversorgung und Lautsprecher:

- Die Lautsprecherleitungen des Netzkabels **NICHT** an der Autobatterie anschließen, da sonst das Gerät schwer beschädigt wird.
- VOR dem Anschließen der Lautsprecherleitungen des Spannungsversorgungskabels an die Lautsprecher, die Lautsprecherverdrahtung in Ihrem Auto überprüfen.

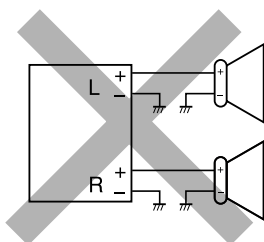

ПРЕДОСТЕРЕЖЕНИЯ по питанию и подключению громкоговорителей:

- **НЕ подключайте провода громкоговорителей к аккумулятору автомобиля, иначе устройство будет повреждено.**
- ПЕРЕД подключением проводов громкоговорителей к кабелю питания громкоговорителя проверьте схему соединений громкоговорителей в Вашем автомобиле.

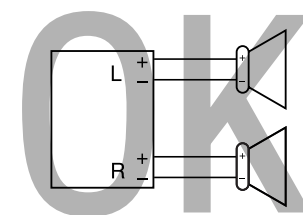

Parts list for installation and DC connection

The following parts are provided for this unit. If any item is missing, consult your JVC IN-CAR ENTERTAINMENT dealer immediately.

Teilleiste für den Einbau und Anschluß

Die folgenden Teile werden zusammen mit diesem Gerät geliefert. Falls ein Artikel fehlt, wenden Sie sich sofort an Ihren JVC-Autoradiohändler.

Список деталей для установки и подключения

Следующие детали поставлены в комплекте с устройством. При отсутствии какого-либо элемента немедленно свяжитесь с дилером автомобильного специалиста JVC.

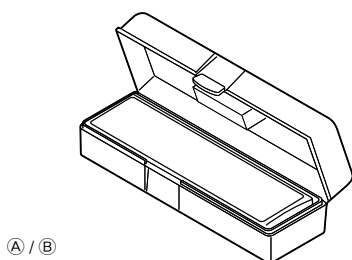

A / B
Hard case/Control panel
Etui/Schalttafel
Жесткий футляр/панель управления

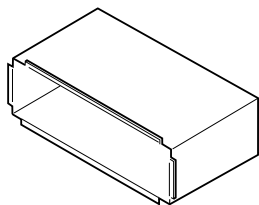

C
Sleeve
Halterung
Муфта

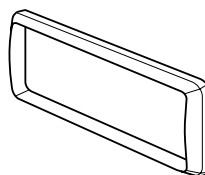

D
Trim plate
Frontrahmen
Декоративную панель

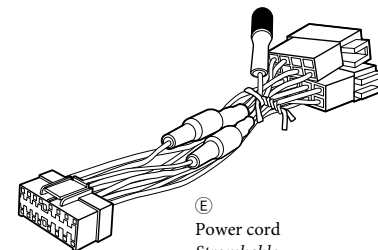

E
Power cord
Stromkabel
Кабель питания



F
Connection cable for iPod
Verbindungskabel für iPod
Соединительный кабель для iPod

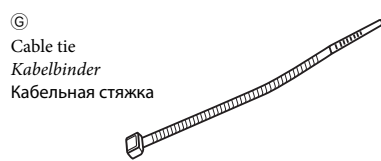

G
Cable tie
Kabelbinder
Кабельная стяжка

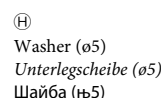

H
Washer (ø5)
Unterlegscheibe (ø5)
Шайба (5мм)



I
Lock nut (M5)
Sicherungsmutter (M5)
Фиксирующая гайка (M5)



J
Mounting bolt (M5 × 20 mm)
Befestigungsschraube (M5 × 20 mm)
Крепежный болт (M5 × 20 мм)

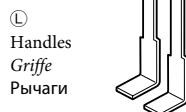

K
Rubber cushion
Gummipuffer
Резиновый чехол



M
Remote controller
Fernbedienung
Дистанционного управления



N
Battery
Batterie
Батарейка



CR2025

INSTALLATION (IN-DASH MOUNTING)

The following illustration shows a typical installation. If you have any questions or require information regarding installation kits, consult your JVC IN-CAR ENTERTAINMENT dealer or a company supplying kits.

- If you are not sure how to install this unit correctly, have it installed by a qualified technician.

EINBAU (IM ARMATURENBRETT)

Die folgende Abbildung zeigt einen typischen Einbau. Bei irgendwelchen Fragen oder wenn Sie Informationen hinsichtlich des Einbausatzes brauchen, wenden Sie sich an ihren JVC Autoradiohändler oder ein Unternehmen das diese Einbausätze vertreibt.

- Sind Sie sich über den richtigen Einbau des Geräts nicht sicher, lassen Sie es von einem qualifizierten Techniker einbauen.

УСТАНОВКА (УСТАНОВКА В ПРИБОРНУЮ ПАНЕЛЬ)

На следующих иллюстрациях показана типовая установка. Если у Вас есть какие-либо вопросы, касающиеся установки, обратитесь к Вашему дилеру автомобильного специалиста JVC или в компанию, поставляющую соответствующие принадлежности.

- Если Вы не знаете точно, как следует устанавливать это устройство, обратитесь к квалифицированному специалисту.

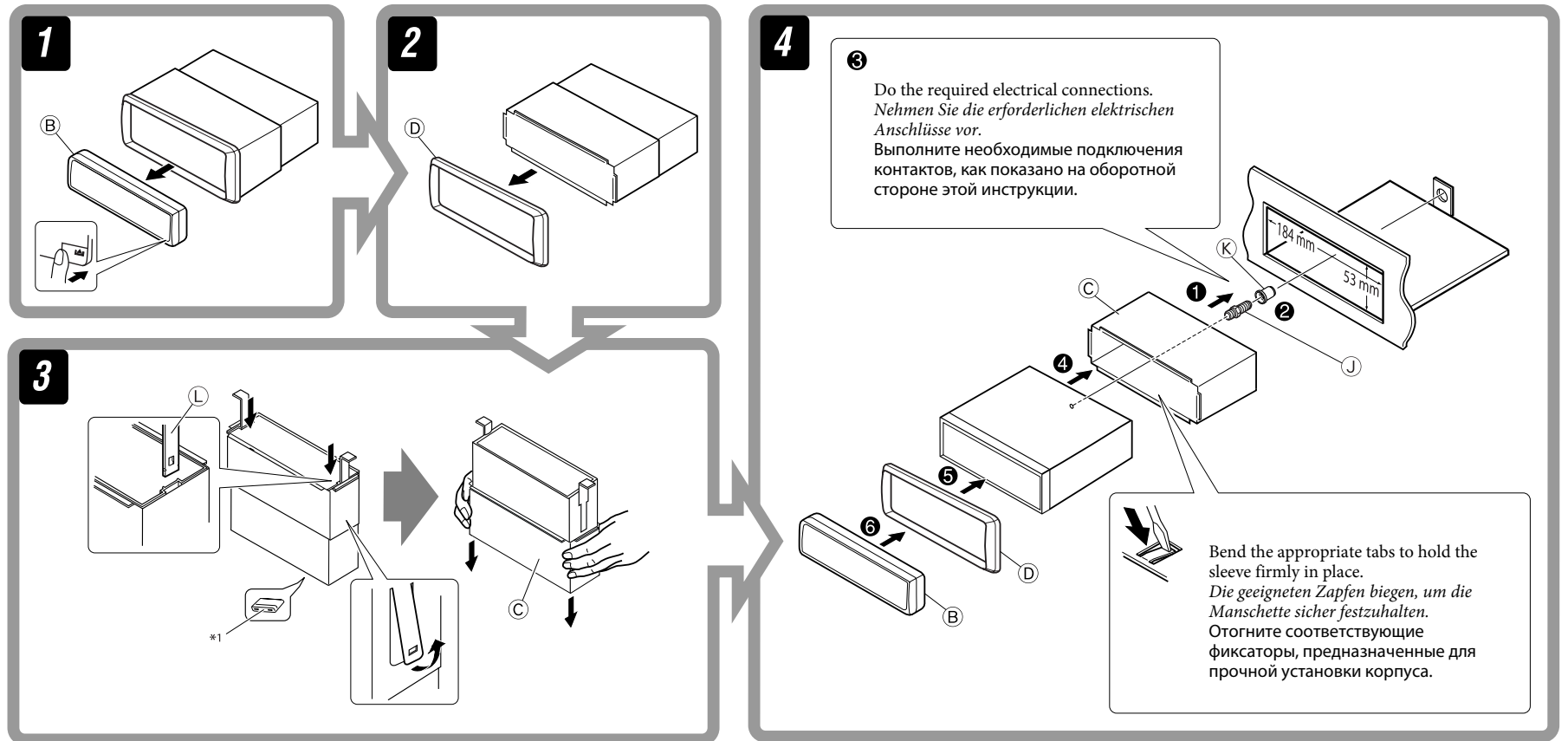

Removing the unit

Before removing the unit, release the rear section.

Ausbau des Geräts

Vor dem Ausbau des Geräts den hinteren Teil freigeben.

Удаление устройства

Перед удалением устройства освободите заднюю часть.

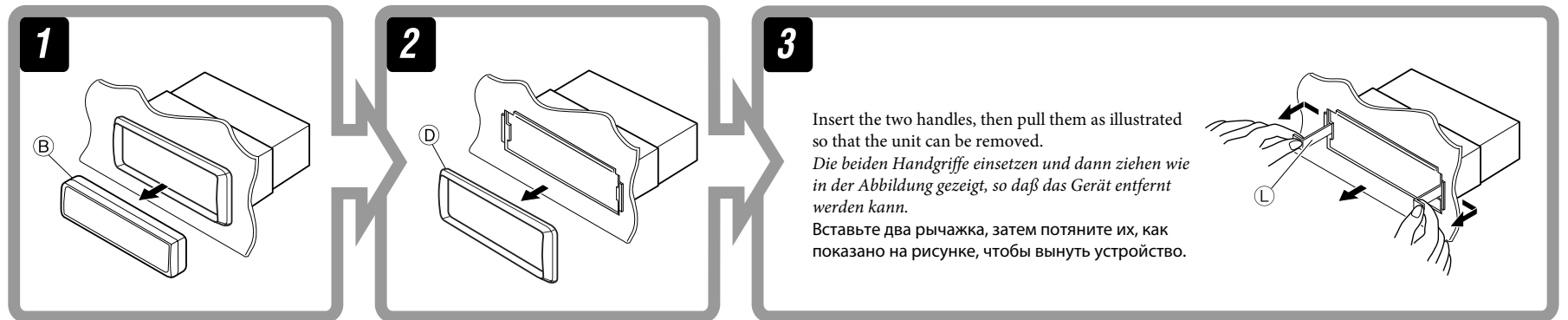

When using the optional stay / Beim Verwenden der Anker-Option / При использовании дополнительной стойки

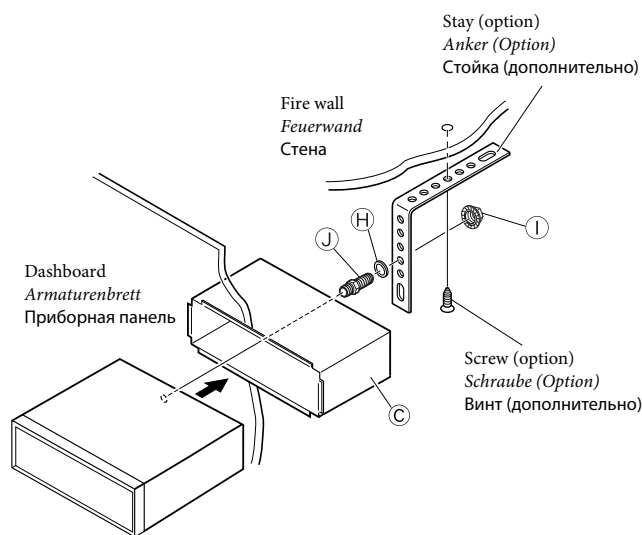

Install the unit at an angle of less than 30°. *Stellen Sie das Gerät mit einem Winkel von weniger als 30° auf.* Установите устройство под углом менее 30°.

When installing the unit without using the sleeve / Beim Einbau des Geräts ohne Halterung / При установке устройства без использования муфты

In a Toyota car for example, first remove the car radio and install the unit in its place.

Zum Beispiel in einem Toyota zuerst das Autoradio ausbauen und dann das Gerät an seinem Platz einbauen.

В автомобиле Тойота, например, сначала извлеките автомобильный радиоприемник и установите устройство на место.

Flat type screws (M5 × 8 mm)*2
Senkkopfschrauben (M5 × 8 mm)*2
Крепежные винты (M5 × 8 мм)*2

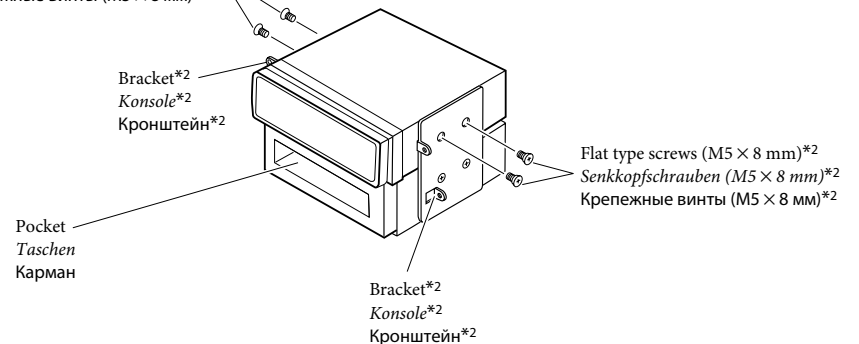

Note

• When installing the unit on the mounting bracket, make sure to use the 8 mm-long screws. If longer screws are used, they could damage the unit.

Hinweis

• Beim Anbringen des Gerät an der Konsole sicherstellen, daß 8 mm lange Schrauben verwendet werden. Werden längere Schrauben verwendet, können sie das Gerät beschädigen.

Примечание

• При установке устройства на крепежный кронштейн, используйте только винты длиной 8 мм. При использовании более длинных винтов можно повредить устройство.

*1 When you stand the unit, be careful not to damage the fuse on the rear.
*2 Not supplied for this unit.

*1 Beim Aufstellen des Geräts darauf achten, daß die Sicherung auf der Rückseite nicht beschädigt wird.
*2 Wird nicht mit Gerät mitgeliefert.

*1 Устанавливайте устройство таким образом, чтобы не повредить предохранитель, расположенный сзади.
*2 Не входит в комплект поставки.

ELECTRICAL CONNECTIONS

ELEKTRISCHE ANSCHLÜSSE

ЭЛЕКТРИЧЕСКИЕ ПОДКЛЮЧЕНИЯ

A If your car is equipped with the ISO connector / Wenn Ihr Fahrzeug mit dem ISO-Steckverbinder ausgestattet ist / Если автомобиль оснащен разъемом ISO

- Connect the ISO connectors as illustrated.
- Schließen Sie die ISO-Steckverbinder an, wie in der Abbildung gezeigt.
- Подключите разъемы ISO, как показано на рисунке.

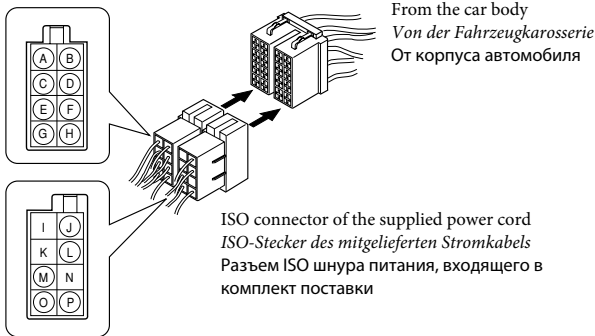

For some VW/Audi or Opel (Vauxhall) automobile / Bei bestimmten VW-/Audi- oder Opel- (Vauxhall-) Fahrzeugen / Для некоторых автомобилей VW/Audi или Opel (Vauxhall)

You may need to modify the wiring of the supplied power cord as illustrated.

- Contact your authorized car dealer before installing this unit.
- Es kann erforderlich sein, die Verdrahtung des mitgelieferten Stromkabels zu modifizieren, wie in der Abbildung gezeigt.
- Wenden Sie sich vor dem Einbau dieses Receivers an Ihre Auto-Fachwerkstatt.

Возможно, потребуется изменить схему соединений для прилагаемого шнура питания, как показано на рисунке.

Original wiring / Original verdrahtung / Исходная схема соединений

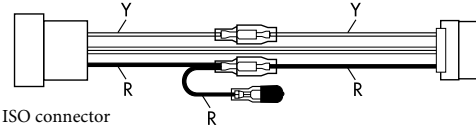

ISO connector
ISO-Steckverbinder
Разъем ISO

Modified wiring 1 / Modifizierte Verdrahtung 1 / Преобразованная схема соединений 1

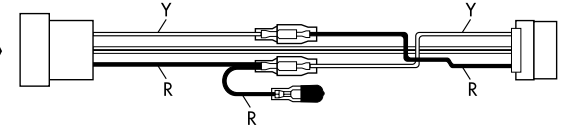

Use modified wiring 2 if the unit does not turn on.
Verwenden Sie die modifizierte Verdrahtung 2 wenn der Receiver nicht einschaltet.
Если приемник не включается, используйте преобразованную схему соединений 2.

Modified wiring 2 / Modifizierte Verdrahtung 2 / Преобразованная схема соединений 2

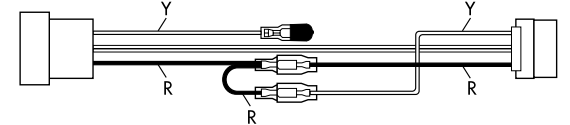

Y: Yellow
Gelb
Желтый
R: Red
Rot
Красный

B Connections without using the ISO connectors / Anschlüsse ohne Verwendung der ISO-Steckverbinder / Подключение без использования разъемов ISO

Before connecting: Check the wiring in the vehicle carefully. Incorrect connection may cause serious damage to this unit. The leads of the power cord and those of the connector from the car body may be different in color.

Vor dem Anschließen: Die Verdrahtung im Fahrzeug sorgfältig überprüfen. Falsche Anschlüsse können ernsthafte Schäden am Gerät hervorrufen. Die Leiter des Stromkabels und die Leiter des Anschlusses im Fahrzeug können sich farblich unterscheiden.

Перед началом подключений: Тщательно проверьте проводку в автомобиле. Неправильное подключение может привести к серьезному повреждению устройства. Жилы силового кабеля и жилы соединителя от кузова автомобиля могут быть разного цвета.

- 1 Cut the ISO connector.
- 2 Connect the colored leads of the power cord in the order specified in the illustration below.
- 3 Connect the aerial cord.
- 4 Finally connect the wiring harness to the unit.

- 1 Schneiden Sie den ISO-Steckverbinder auf.
- 2 Die farbigen Adern des Stromkabels in der Reihenfolge anschließen, wie in der Abbildung unten gezeigt.
- 3 Das Antennenkabel anschließen.
- 4 Die Kabelbäume am Gerät anschließen.

- 1 Обрежьте разъем ISO.
- 2 Подсоедините цветные провода шнура питания в указанном ниже порядке.
- 3 Подключите кабель антенны.
- 4 В последнюю очередь подключите электропроводку к устройству.

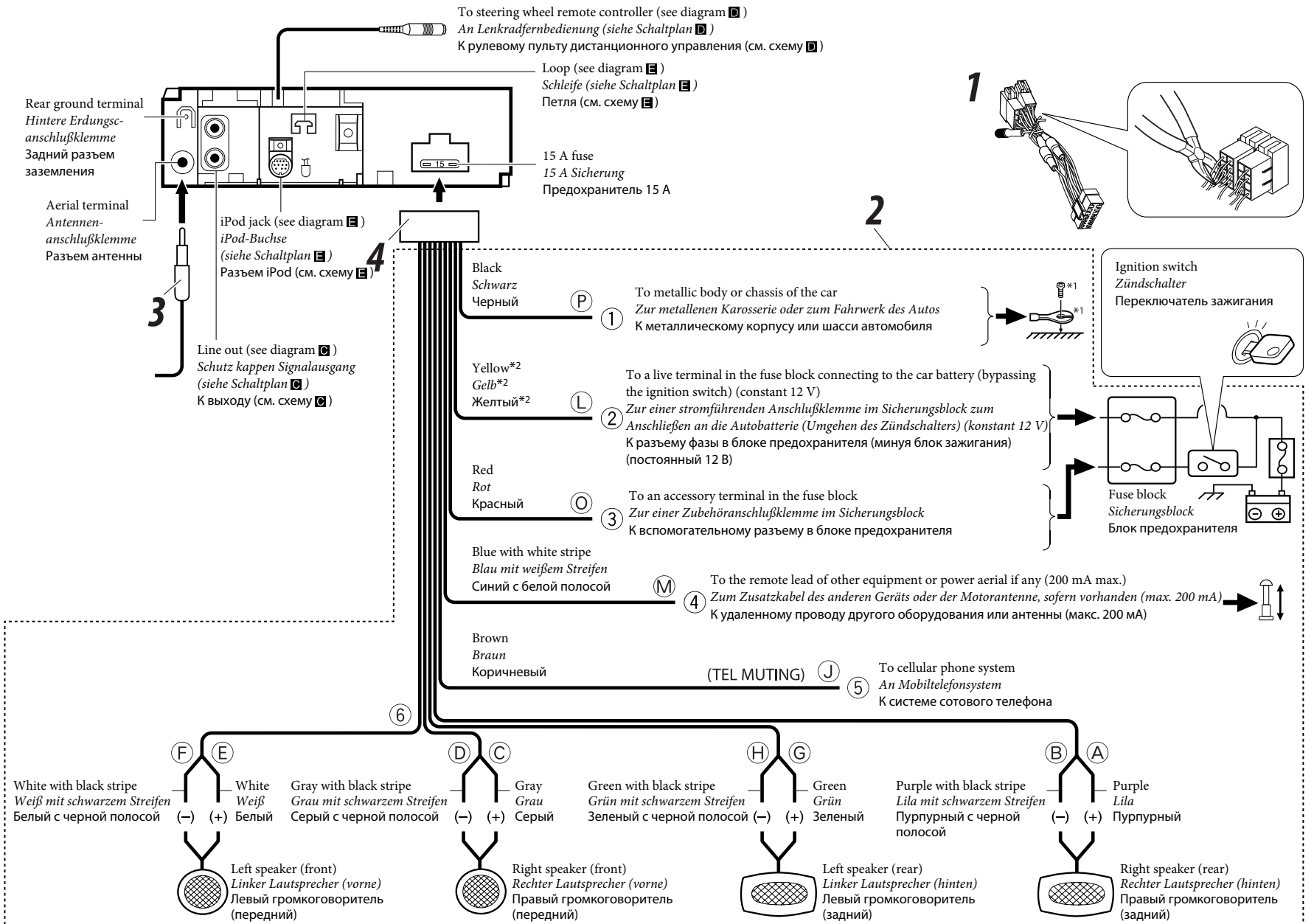

*1 Not supplied for this unit.
*2 Before checking the operation of this unit prior to installation, this lead must be connected, otherwise power cannot be turned on.

*1 Wird nicht mit Gerät mitgeliefert.
*2 Vor der Überprüfung der Funktionsfähigkeit des Geräts vor dem Einbau, muß diese Leitung angeschlossen werden, da sonst die Stromversorgung nicht eingeschaltet werden kann.

*1 Не входит в комплект поставки.
*2 Перед проверкой работы устройства подключите этот провод, иначе питание не включится.

C Connecting the external amplifier / Anschließen des externen Verstärkers / Подключение внешнего усилителя

You can connect an amplifier to upgrade your car stereo system.

- Connect the remote lead (blue with white stripe) to the remote lead of the other equipment so that it can be controlled through this unit.
- **Disconnect the speakers from this unit, connect them to the amplifier. Leave the speaker leads of this unit unused.**

Sie können einen Verstärker anschließen, um Ihre Autostereoanlage zu erweitern.

- Schließen Sie das Fernbedienungskabel (blau mit weißem Streifen) an das Fernbedienungskabel des anderen Geräts an, so daß es über dieses Gerät gesteuert werden kann.
- **Die Lautsprecher von diesem Gerät abtrennen und am Verstärker anschließen. Die Lautsprecherleitungen dieses Geräts unbenutzt lassen.**

Можно подключить усилитель для обновления автомобильной стереосистемы.

- Подсоедините провод внешнего устройства (синий с белой полосой) к проводу внешнего устройства другого оборудования так, чтобы им можно было управлять с этого устройства.
- **Отсоедините громкоговорители от данного устройства, подключите их к усилителю. Оставьте провода громкоговорителей данного устройства неиспользованными.**

Remote lead
Fernbedienungsleitung
Провод внешнего устройства

Y-connector (not supplied for this unit)
Y-Anschluß (wird nicht mit Gerät mitgeliefert)
Разъем Y (не входит в комплект поставки)

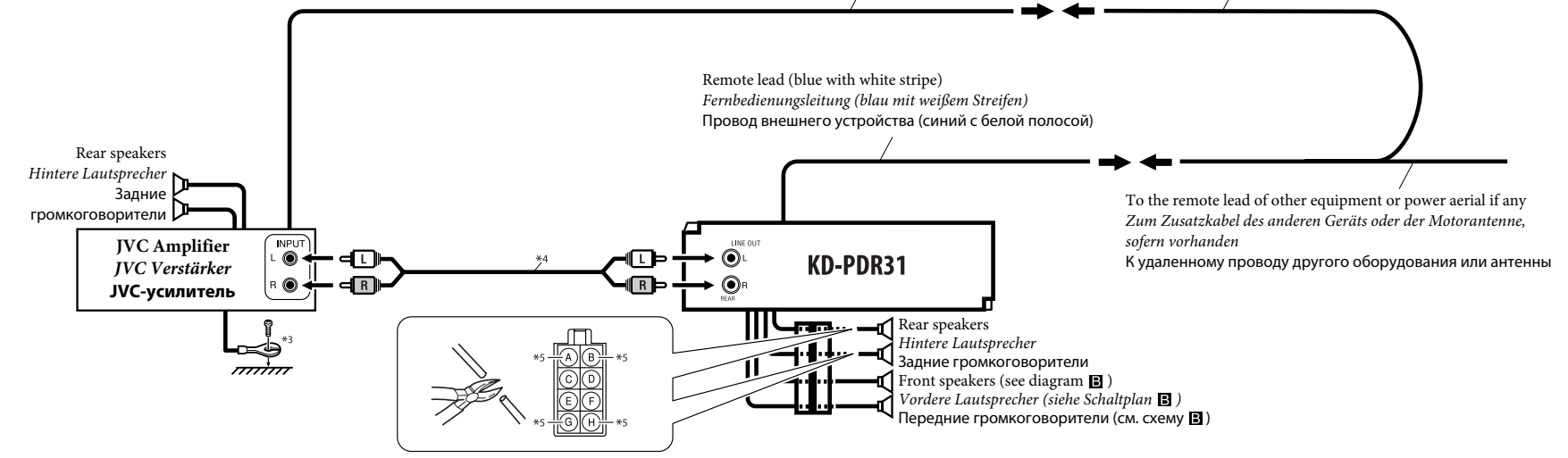

D Connecting to the steering wheel remote controller / Anschluß an die Lenkradfernbedienung / Подключение к рулевому пульту дистанционного управления

If your car is equipped with the steering wheel remote controller, you can operate this unit using the controller. To do it, a JVC's OE remote adapter (not supplied) which matches with your car is required. Consult your JVC IN-CAR ENTERTAINMENT dealer for details.

Wenn Ihr Fahrzeug mit einer Lenkradfernbedienung ausgestattet ist, können Sie damit diesen Receiver steuern. Hierfür ist ein für Ihr Fahrzeug passender Radio-Lenkrad-Fernbedienungsadaption von JVC (nicht mitgeliefert) erforderlich. Für weitere Einzelheiten wenden Sie sich an Ihren JVC Autoradiohändler.

Если автомобиль оборудован рулевым пультом дистанционного управления, его можно использовать для управления данным устройством. Для этого необходим адаптер рулевого пульта дистанционного управления JVC OE (не поставляется), подходящий для Вашего автомобиля. За более подробной информацией обратитесь к поставщику автомобильных аудиосистем компании JVC.

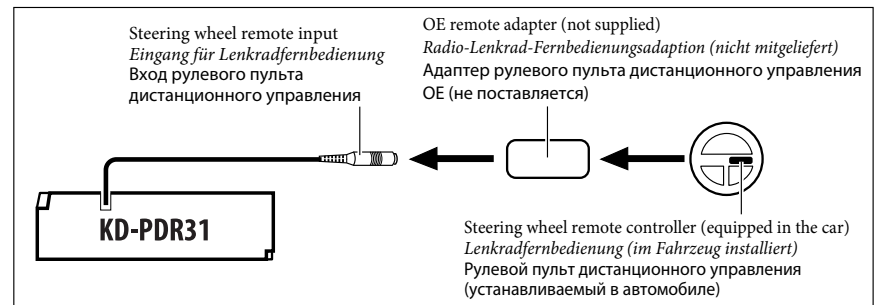

E Connecting an Apple iPod / Anschließen eines Apple iPod / Подключение проигрывателя Apple iPod

You can connect an iPod to this unit using the supplied connection cable for iPod.

- 1 Insert the supplied cable tie across the loop.
- 2 Press in the head of the connection cable for iPod until you hear a clicking sound.
- 3 Fasten the connection cable using the cable tie to firmly hold the connection cable in place.

Sie können einen Apple iPod an dieses Gerät durch Verwendung des mitgelieferten Verbindungskabels für iPod anschließen.

- 1 Führen Sie den mitgelieferten Kabelbinder über die Schleife.
 - 2 Drücken Sie den Kopf des Anschlusskabels für den iPod ein, bis Sie ein Klickgeräusch hören.
 - 3 Befestigen Sie das Verbindungskabel mit dem mitgelieferten Kabelbinder, um das Verbindungskabel fest zu sichern.
- Проигрыватель iPod можно подключить к устройству с помощью соединительного кабеля для iPod.
- 1 Вставьте прилагаемый шнурок соединительного кабеля в петлю.
 - 2 Нажимайте на наконечник соединительного кабеля для iPod до тех пор, пока не услышите звук щелчка.
 - 3 Прикрепите соединительный кабель с помощью шнурка кабеля для надежного крепления кабеля на месте.

Apple iPod (separately purchased)
Apple iPod (getrennt gekauft)
Apple iPod (продается отдельно)

Connection cable for iPod
(supplied)
Verbindungskabel für iPod
(mitgeliefert)
Соединительный кабель для iPod (входит в комплект поставки)

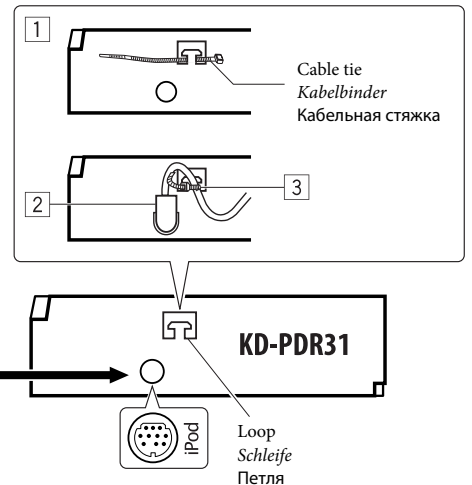

iPod is a trademark of Apple Computer, Inc., registered in the U.S. and other countries.
iPod ist ein Warenzeichen von Apple Computer, Inc., eingetragen in den USA und anderen Ländern.
iPod является торговой маркой Apple Computer, Inc., зарегистрированной в США и других странах.

*3 Firmly attach the ground wire to the metallic body or to the chassis of the car—to the place uncoated with paint (if coated with paint, remove the paint before attaching the wire). Failure to do so may cause damage to the unit.

*4 Signal cord (not supplied for this unit)

*5 Cut the rear speaker leads of the car's ISO connector and connect them to the amplifier.

*3 Verbinden Sie den Erdungsleiter mit der Karosserie oder dem Rahmen des Fahrzeugs. Die Kontaktstelle darf nicht lackiert sein (sollte die Kontaktstelle lackiert sein, entfernen Sie den Lack der Kontaktstelle, bevor Sie den Leiter befestigen). Wenn der Erdungsleiter nicht ordnungsgemäß angeschlossen wird, kann dieses Gerät beschädigt werden.

*4 Einzelleitung (wird nicht mit Gerät mitgeliefert)

*5 Schneiden Sie die hinteren Lautsprecherkabel des ISO-Steckverbinders des Fahrzeugs ab, und schließen diese an den Verstärker an.

*3 Плотно прикрепите заземляющий провод к металлическому кузову или шасси автомобиля—в месте, не покрытом краской (если оно покрыто краской, удалите краску перед тем, как прикреплять провод). Невыполнение этого требования может привести к повреждению данного устройства.

*4 Кабель сигнала (не входит в комплект поставки)

*5 Отрежьте провода задних громкоговорителей разъема ISO и подсоедините их к усилителю.

TROUBLESHOOTING

• The fuse blows.

* Are the red and black leads connected correctly?

• Power cannot be turned on.

* Is the yellow lead connected?

• No sound from the speakers.

* Is the speaker output lead short-circuited?

• Sound is distorted.

* Is the speaker output lead grounded?

* Are the “-” terminals of L and R speakers grounded in common?

• Noise interfere with sounds.

* Is the rear ground terminal connected to the car's chassis using shorter and thicker cords?

• This unit becomes hot.

* Is the speaker output lead grounded?

* Are the “-” terminals of L and R speakers grounded in common?

• This unit does not work at all.

* Have you reset your unit?

FEHLERSUCHE

• Die Sicherung brennt durch.

* Sind die roten und schwarzen Leitungen richtig angeschlossen?

• Stromversorgung kann nicht eingeschaltet werden.

* Ist die gelbe Leitung angeschlossen?

• Kein Ton aus den Lautsprechern.

* Ist die Lautsprecherausgangsleitung kurzgeschlossen?

• Ton verzerrt.

* Ist die Lautsprecherausgangsleitung geerdet?

* Sind die „-“ Anschlussklemmen der linken und rechten Lautsprecher zusammen geerdet?

• Störgeräusche im Klang.

* Ist die hintere Erdungsklemme mit kürzeren und dickeren Kabeln an das Fahrzeugchassis angeschlossen?

• Gerät wird heiß.

* Ist die Lautsprecherausgangsleitung geerdet?

* Sind die „-“ Anschlussklemmen der linken und rechten Lautsprecher zusammen geerdet?

• Dieser Receiver funktioniert überhaupt nicht.

* Haben Sie einen Reset am Receiver vorgenommen?

ВЫЯВЛЕНИЕ НЕИСПРАВНОСТЕЙ

• Сработал предохранитель.

* Правильно ли подключены черный и красный провода?

• Питание не включается.

* Подключен ли желтый провод?

• Звук не выводится через громкоговорители.

* Нет ли короткого замыкания на кабеле выхода громкоговорителей?

• Звук искажен.

* Заземлен ли провод выхода громкоговорителей?

* Заземлены ли разъемы “-” правого (R) и левого (L) громкоговорителей?

• Шум мешает звучанию.

* Соединен ли находящийся сзади зажим заземления с шасси автомобиля с помощью более короткого и тонкого шнуров?

• Устройство нагревается.

* Заземлен ли провод выхода громкоговорителей?

* Заземлены ли разъемы “-” правого (R) и левого (L) громкоговорителей?

• Приемник не работает.

* Выполнена ли перенастройка приемника?

JVC

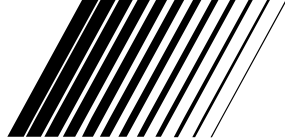

CD RECEIVER

KD-PDR35

ENGLISH

เครื่องเล่น CD

KD-PDR35

ไทย

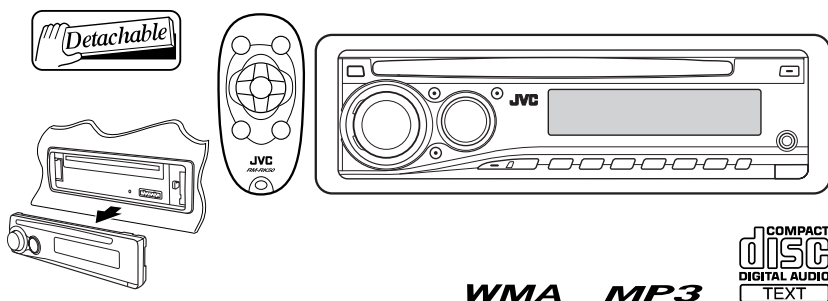

For canceling the display demonstration, see page 6.

ดูที่หน้า 6 เพื่อยกเลิกการสาธิตภาพประกอบ

For installation and connections, refer to the separate manual.

กรุณาดูคู่มือที่แยกต่างหาก ในการติดตั้งและการเชื่อมต่อ

INSTRUCTIONS

คำแนะนำ

GET0468-001A
[U/UH]

Thank you for purchasing a JVC product.

Please read all instructions carefully before operation, to ensure your complete understanding and to obtain the best possible performance from the unit.

IMPORTANT FOR LASER PRODUCTS

1. CLASS 1 LASER PRODUCT
2. **CAUTION:** Do not open the top cover. There are no user serviceable parts inside the unit; leave all servicing to qualified service personnel.
3. **CAUTION:** Visible and/or invisible class 1M laser radiation when open. Do not view directly with optical instruments.
4. REPRODUCTION OF LABEL: CAUTION LABEL, PLACED OUTSIDE THE UNIT.

CAUTION VISIBLE AND/OR INVISIBLE CLASS 1M LASER RADIATION WHEN OPEN. DO NOT VIEW DIRECTLY WITH OPTICAL INSTRUMENTS. IEC60825-1:2001 (ENG)	ATTENTION RAYONNEMENT LASER DE CLASSE 1M VISIBLE ET/OU INVISIBLE DE CLASSE 1M UNE FOIS OUVERT NE PAS REGARDER DIRECTEMENT AVEC DES INSTRUMENTS OPTIQUES. (FRA)	AVISO RADIACION LASER DE CLASE 1M VISIBLE Y/O INVISIBLE CUANDO ESTA ABIERTO. NO MIRAR DIRECTAMENTE CON INSTRUMENTAL OPTICO. (ESP)	VARNING SYNLIG OCH/ELLER OSYNLIG LASERSTRÅLNING, KLASS 1M, NÄR DENNA KLASS 1M, NÄR DENNA DEL ÄR ÖPPNAD. BETRÄKTA EJ STRÅLEN MED OPTISKA INSTRUMENT. (SWE)	注意 この装置と付属品が 放射する不可視の レーザー放射が クラス1M 出ます。 光学儀器で直接 見ないでください。 (JPN)	CAUTION VISIBLE AND/OR INVISIBLE CLASS 1 LASER RADIATION WHEN OPEN. DO NOT STARE INTO BEAM. FDA 21 CFR (ENG)
--	--	--	---	---	---



Warning:

If you need to operate the unit while driving, be sure to look ahead carefully or you may be involved in a traffic accident.

Caution on volume setting:

Discs produce very little noise compared with other sources. Lower the volume before playing a disc to avoid damaging the speakers by the sudden increase of the output level.

How to reset your unit

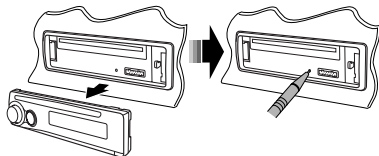

- Your preset adjustments will also be erased.

How to forcibly eject a disc



- Be careful not to drop the disc when it ejects.
- If this does not work, reset your unit.

How to use the M MODE button

If you press M MODE, the unit goes into functions mode, then the number buttons and ▲/▼ buttons work as different function buttons.

Ex.: When number button 2 works as MO (monaural) button.



To use these buttons for their original functions again after pressing M MODE, wait for 5 seconds without pressing any of these buttons until the functions mode is cleared or press M MODE again.

Detaching the control panel

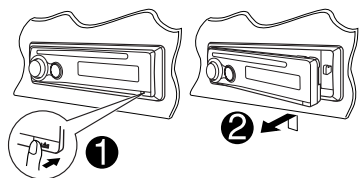

Attaching the control panel

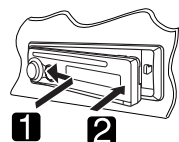

CONTENTS

Control panel	4
Remote controller — RM-RK50.....	5
Getting started	6
Basic operations	6
Radio operations	7
Disc operations	8
Playing a disc in the unit	8
iPod operations	11
Sound adjustments	13
General settings — PSM	14
External component operations	16
Maintenance	16
More about this unit	17
Troubleshooting	21
Specifications	23

For safety...

- Do not raise the volume level too much, as this will block outside sounds, making driving dangerous.
- Stop the car before performing any complicated operations.

Temperature inside the car...

If you have parked the car for a long time in hot or cold weather, wait until the temperature in the car becomes normal before operating the unit.

Control panel

Parts identification

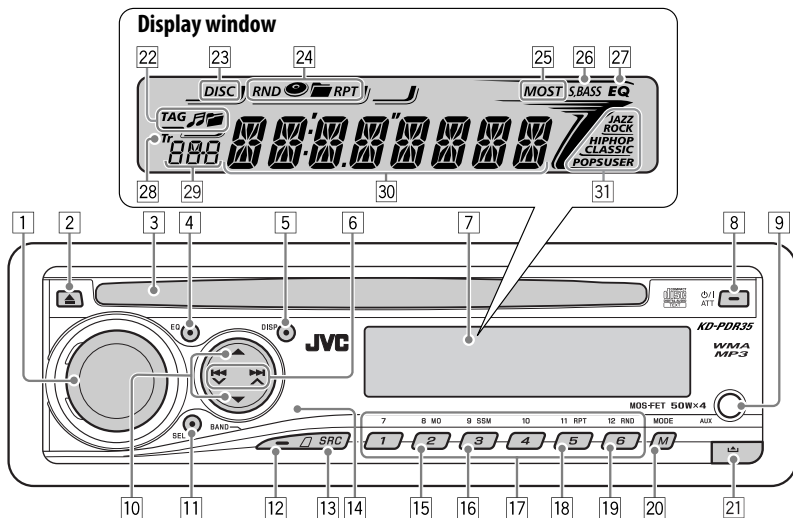

- | | | | |
|----|---|----|---|
| 1 | Control dial | 19 | RND (random) button |
| 2 | ▲ (eject) button | 20 | M MODE button |
| 3 | Loading slot | 21 | ⏏ (control panel release) button |
| 4 | EQ (equalizer) button | 22 | Disc information indicators—
TAG (Tag information), 📁 (track/file), 📁 (folder) |
| 5 | DISP (display) button | 23 | DISC indicator |
| 6 | ⏮ ⏪ ⏩ ⏭ buttons | 24 | Playback mode / item indicators—RND (random),
📁 (disc), 📁 (folder), RPT (repeat) |
| 7 | Display window | 25 | Tuner reception indicators—MO (monaural),
ST (stereo) |
| 8 | ⏻/⏷ ATT (standby/on attenuator) button | 26 | S.BASS (super bass) indicator |
| 9 | AUX (auxiliary) input jack | 27 | EQ (equalizer) indicator |
| 10 | ▲ (up) / ▼ (down) buttons | 28 | Tr (track) indicator |
| 11 | SEL (select) button | 29 | Source display / Time countdown indicator |
| 12 | BAND button | 30 | Main display |
| 13 | SRC (source) button | 31 | Sound mode (iEQ: intelligent equalizer)
indicators—JAZZ, ROCK, HIP HOP, CLASSIC, POPS,
USER |
| 14 | Remote sensor
<i>DO NOT expose the remote sensor to strong light
(direct sunlight or artificial lighting).</i> | | |
| 15 | MO (monaural) button | | |
| 16 | SSM (Strong-station Sequential Memory) button | | |
| 17 | Number buttons | | |
| 18 | RPT (repeat) button | | |

Installing the lithium coin battery (CR2025)

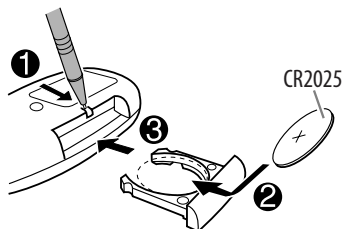

Aim the remote controller directly at the remote sensor on the unit. Make sure there is no obstacle in between.

Warning:

- Do not install any battery other than CR2025 or its equivalent; otherwise, it may explode.
- Do not leave the remote controller in a place (such as dashboards) exposed to direct sunlight for a long time; otherwise, it may explode.
- Store the battery in a place where children cannot reach to avoid risk of accident.
- To prevent the battery from over-heating, cracking, or starting a fire:
 - Do not recharge, short, disassemble, heat the battery, or dispose of it in a fire.
 - Do not leave the battery with other metallic materials.
 - Do not poke the battery with tweezers or similar tools.
 - Wrap the battery with tape and insulate when throwing away or saving it.

Main elements and features

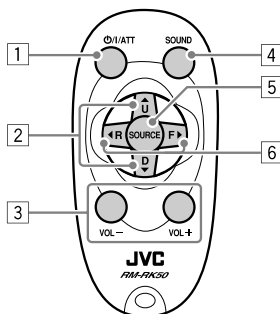

- 1 **⏻ / I / ATT** (standby/on/attenuator) button
 - Turns the power on if pressed briefly or attenuates the sound when the power is on.
 - Turns the power off if pressed and held.
- 2 **▲ U** (up) / **D** (down) **▼** buttons
 - Changes the FM/AM bands with **▲ U**.
 - Changes the preset stations with **D ▼**.
 - Changes the folder of the MP3/WMA discs.
 - While listening to an Apple iPod.
 - Pauses or resumes playback with **D ▼**.
 - Enters the main menu with **▲ U**.
(Now **▲ U**/**D ▼**/**◀ R**/**F ▶** work as the menu selecting buttons.)*
- 3 **VOL -** / **VOL +** buttons
 - Adjusts the volume level.
- 4 **SOUND** button
 - Selects the sound mode (iEQ: intelligent equalizer).
- 5 **SOURCE** button
 - Selects the source.

- * **▲ U** : Returns to the previous menu.
D ▼ : Confirms the selection.

- 6 ◀ R (reverse) / F (forward) ▶ buttons
- Searches for stations if pressed briefly.
 - Fast-forwards or reverses the track if pressed and held.
 - Changes the tracks if pressed briefly.
 - While listening to an iPod (in menu selecting mode):
 - Selects an item if pressed briefly. (Then, press D ▼ to confirm the selection.)
 - Skips 10 items at a time if pressed and held.

Getting started

Basic operations

1 Turn on the power.



2 SRC

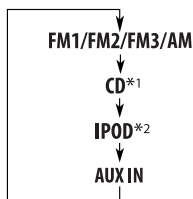

*1 You cannot select "CD" as the playback source if there is no disc in the unit.

*2 "NO IPOD" appears if iPod is not connected.

3 For FM/AM tuner



4 Adjust the volume.

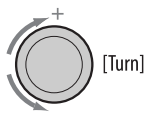

VOL 20

Volume level appears.

5 Adjust the sound as you want. (See page 13.)

To drop the volume in a moment (ATT)

To restore the sound, press the button again.



To turn off the power



Basic settings

- See also "General settings — PSM" on pages 14 and 15.

1 SEL [Hold]

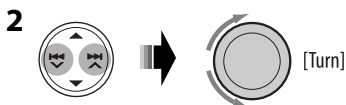

1 Canceling the display demonstrations

Select "DEMO," then "DEMO OFF."

2 Setting the clock

Select "CLOCK H" (hour), then adjust the hour. Select "CLOCK M" (minute), then adjust the minute.

3 Finish the procedure.



To check the current clock time while the power is turned off



Clock time is shown on the display for about 5 seconds. See also page 14.

Radio operations

1



2



Lights up when receiving an FM stereo broadcast with sufficient signal strength.



3

Start searching for a station.



When a station is received, searching stops.

To stop searching, press the same button again.

To tune in to a station manually

In step 3 above...

1



2 Select a desired station frequency.



When an FM stereo broadcast is hard to receive



Lights up when monaural mode is activated.



Reception improves, but stereo effect will be lost.

To restore the stereo effect, repeat the same procedure. "MONO OFF" appears and the MO indicator goes off.

Storing stations in memory

You can preset six stations for each band.

FM station automatic presetting—SSM (Strong-station Sequential Memory)

1 Select the FM band (FM1 – FM3) you want to store into.



2



3







"SSM" flashes, then disappears when automatic presetting is over.

Local FM stations with the strongest signals are searched and stored automatically in the FM band.

Manual presetting

Ex.: Storing FM station of 92.5 MHz into preset number 4 of the FM1 band.

- 
- 

- 

Preset number flashes for a while.

Listening to a preset station

- 
- Select the preset station (1 – 6) you want.



or



To check other information while listening to the radio



Clock ↔ Frequency

Disc operations

Playing a disc in the unit

All tracks will be played repeatedly until you change the source or eject the disc.

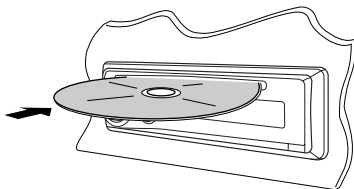

To stop play and eject the disc



- Press SRC to listen to another playback source.

To fast-forward or reverse the track



To go to the next or previous tracks



To go to the next or previous folders (only for MP3 or WMA discs)



To locate a particular track (for CD) or folder (for MP3 or WMA discs) directly

To select a number from 01 – 06:



To select a number from 07 – 12:



[Hold]

- To use direct folder access on MP3/WMA discs, it is required that folders are assigned with 2-digit numbers at the beginning of their folder names—01, 02, 03, and so on.

To select a particular track in a folder (for MP3 or WMA discs):



Other main functions

■ Skipping tracks quickly during play

- For MP3 or WMA discs, you can skip tracks within the same folder.

Ex.: To select track 32 while playing a track whose number is a single digit (1 to 9)

1 MODE

2 → Track 1 to 9 → Track 10
..... 30 ← 20 ←

Each time you press the button, you can skip 10 tracks.

- After the last track, the first track will be selected and vice versa.

3 → Track 31 → 32 →

■ Prohibiting disc ejection

You can lock a disc in the loading slot.

+
[Hold]



To cancel the prohibition, repeat the same procedure.

Changing the display information



■ While playing an audio CD or a CD Text



■ While playing an MP3 or a WMA track

- When "TAG DISP" is set to "TAG ON" (see page 15)

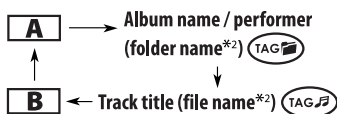

- When "TAG DISP" is set to "TAG OFF"

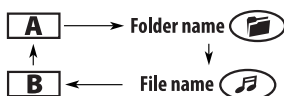

- A** : Clock with the current track number
- B** : Elapsed playing time with the current track number
- : Corresponding indicator lights up on the display

*1 If the current disc is an audio CD, "NO NAME" appears.

*2 If an MP3/WMA file does not have Tag information, folder name and file name appear. In this case, the TAG indicator will not light up.

Selecting the playback modes

You can use only one of the following playback modes at a time.

- 1 **MODE**
- 2 **Select your desired playback mode.**

- **Repeat play** 11 RPT

Mode	Plays repeatedly
TRK RPT	: The current track.
FLDR RPT*	: All tracks of the current folder.
RPT OFF	: Cancels.

- **Random play** 12 RND

Mode	Plays at random
FLDR RND*	: All tracks of the current folder, then tracks of the next folder and so on.
DISC RND	: All tracks of the current disc.
RND OFF	: Cancels.

* Only while playing an MP3 or a WMA disc.

: Corresponding indicator lights up on the display

iPod operations

You can play songs from an Apple iPod through this unit by connecting it with the supplied connection cable for iPod.

- Disconnecting the iPod will stop playback. Press SRC to listen to another playback source.
- For connection, see Installation/Connection Manual (separate volume).
- For details, refer also to the manual supplied with your iPod.

1 Connect an iPod.

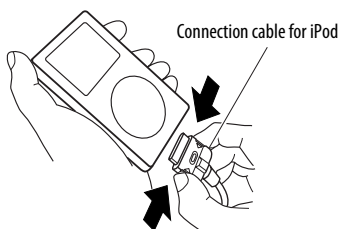

If an iPod has been connected...



Playback starts automatically from where it has been paused previously.

2 Adjust the volume.

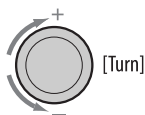

3 Adjust the sound as you want. (See page 13.)

Caution:

- Avoid using the iPod if it might hinder your safety driving.
- Make sure all important data has been backed up to avoid losing the data.

To pause playback



To resume playback, press the button again.

To fast-forward or reverse the track



To go to the next or previous tracks



Selecting a track from the menu

1 Enter the main menu.



Now the ▲/▼/◀/▶/⏪/⏩/⏮/⏭ buttons work as the menu selecting buttons*.

2 Select the desired menu.



PLAYLIST ↔ ARTISTS ↔ ALBUMS ↔
SONGS ↔ GENRES ↔ COMPOSER ↔
(back to the beginning)

3 Confirm the selection.



To move back to the previous menu, press ▲.

- If a track is selected, playback starts automatically.
- If the selected item has another layer, you will enter the layer. Repeat steps **2** and **3** until the desired track is played (see page 20).
- Holding ◀◀/▶▶/⏪/⏩ can skip 10 items at a time.

- * The menu selecting mode will be canceled:
- If no operations are done for about 5 seconds.
 - When you confirm the selection of a track.

Selecting the playback modes

1 MODE



2 Select your desired playback mode.

■ Repeat play 11 RPT
5

Mode **Playback functions (as on iPod)**

ONE RPT : Same as "Repeat One." RPT

ALL RPT : Same as "Repeat All." ▶▶ RPT

RPT OFF : Cancels.

■ Random play 12 RND
6

Mode **Playback functions (as on iPod)**

ALBM RND* : Same as "Shuffle Albums."



SONG RND : Same as "Shuffle Songs." RND

RND OFF : Cancels.

* Functions only if you select "ALL" in "ALBUMS" of the main "MENU."

○ : Corresponding indicator lights up on the display

To check other information while listening to an iPod



Sound adjustments

You can select a preset sound mode suitable to the music genre (iEQ: intelligent equalizer).



Preset values Indication (For)	BAS ^{*1}	MID ^{*2}	TRE ^{*3}	S.BS ^{*4}
	USER (Flat sound)	00	00	00
ROCK (Rock or disco music)	+03	00	+02	ON
CLASSIC (Classical music)	+01	00	+03	OFF
POPS (Light music)	+02	+01	+02	OFF
HIP HOP (Funk or rap music)	+04	-02	+01	ON
JAZZ (Jazz music)	+03	00	+03	OFF

*1 : Bass; *2 : Mid-range; *3 : Treble; *4 : Super bass

Adjusting the sound

You can adjust the sound characteristics to your preference.

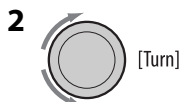
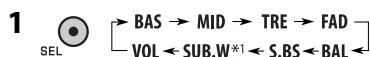

Indication, [Range]

BAS^{*2} (bass), [-06 to +06]

Adjust the bass.

MID^{*2} (mid-range), [-06 to +06]

Adjust the mid-range frequencies sound level.

TRE^{*2} (treble), [-06 to +06]

Adjust the treble.

FAD^{*3} (fader), [R06 to F06]

Adjust the front and rear speaker balance.

BAL^{*4} (balance), [L06 to R06]

Adjust the left and right speaker balance.

S.BS^{*2} (super bass), [S.BS ON or S.BS OFF],

[01 to 05, initial: 03]^{*5}

Maintain the richness and fullness of the bass sound regardless of how low you set the volume.

SUB.W^{*1} (subwoofer), [00 to 08, initial: 04]

Adjust the subwoofer output level.

VOL (volume), [00 to 30 or 50^{*6}]

Adjust the volume.

*1 Displayed only when "L/O MODE" is set to "WOOFER" (see page 15).

*2 When you adjust the bass, mid-range, treble, or super bass, the adjustment you have made is stored for the currently selected sound mode (iEQ) including "USER."

*3 If you are using a two-speaker system, set the fader level to "00."

*4 This adjustment will not affect the subwoofer output.

*5 Range adjustment for super bass is adjustable only when it is set to "S.BS ON."

*6 Depending on the amplifier gain control setting. (See page 15 for details.)

General settings — PSM

You can change PSM (Preferred Setting Mode) items listed in the table that follows.

1  [Hold]

2 Select a PSM item.



3 Adjust the PSM item selected.



4 Repeat steps 2 and 3 to adjust other PSM items if necessary.

5 Finish the procedure.



Indications	Item (__: Initial)	Setting, [reference page]
DEMO Display demonstration	<ul style="list-style-type: none"> • DEMO ON • DEMO OFF 	<ul style="list-style-type: none"> : Display demonstration will be activated automatically if no operation is done for about 20 seconds, [6]. : Cancels.
CLK DISP *1 Clock display	<ul style="list-style-type: none"> • ON • OFF 	<ul style="list-style-type: none"> : Clock time is shown on the display at all times when the power is turned off. : Cancels; pressing DISP will show the clock time for about 5 seconds when the power is turned off, [6].
CLOCK H Hour adjustment	1 – 12	[Initial: 1 (1:00)], [6].
CLOCK M Minute adjustment	00 – 59	[Initial: 00 (1:00)], [6].
DIMMER Dimmer	<ul style="list-style-type: none"> • ON • OFF 	<ul style="list-style-type: none"> : Dims the display illumination. : Cancels.

*1 If the power supply is not interrupted by turning off the ignition key of your car, it is recommended to select "OFF" to save the car's battery.

Indications	Item (__: Initial)	Setting, [reference page]
SCROLL *2 Scroll	<ul style="list-style-type: none"> • ONCE • AUTO • OFF 	<ul style="list-style-type: none"> : Scrolls the track information once. : Repeats scrolling (at 5-second intervals). : Cancels. • Pressing DISP for more than one second can scroll the display regardless of the setting.
L/O MODE Line output mode	<ul style="list-style-type: none"> • REAR • WOOFER 	<ul style="list-style-type: none"> : Select if the REAR LINE OUT terminals are used for connecting the speakers (through an external amplifier). : Select if the REAR LINE OUT terminals are used for connecting a subwoofer (through an external amplifier).
WOOFER *3 Subwoofer cutoff frequency	<ul style="list-style-type: none"> • LOW • MID • HIGH 	<ul style="list-style-type: none"> : Frequencies lower than 90 Hz are sent to the subwoofer. : Frequencies lower than 135 Hz are sent to the subwoofer. : Frequencies lower than 180 Hz are sent to the subwoofer.
AUX ADJ Auxiliary input level adjustment	A.ADJ 00 — A.ADJ 05	: Adjust the auxiliary input level to avoid the sudden increase of the output level when changing the source from external component connected to the AUX input jack on the control panel.
TAG DISP Tag display	<ul style="list-style-type: none"> • TAG ON • TAG OFF 	<ul style="list-style-type: none"> : Shows the Tag information while playing MP3/WMA tracks, [10]. : Cancels.
AMP GAIN Amplifier gain control	<ul style="list-style-type: none"> • LOW PWR • HIGH PWR 	<ul style="list-style-type: none"> : VOL 00 – VOL 30. (Select this if the maximum power of the speaker is less than 50 W to prevent damaging the speaker.) : VOL 00 – VOL 50.
IF BAND Intermediate frequency band	<ul style="list-style-type: none"> • AUTO • WIDE 	<ul style="list-style-type: none"> : Increases the tuner selectivity to reduce interference noises between close stations. (Stereo effect may be lost.) : Subject to interference noises from adjacent stations, but sound quality will not be degraded and the stereo effect will remain.

*2 Some characters or symbols will not be shown correctly (or will be blanked) on the display.

*3 Displayed only when "L/O MODE" is set to "WOOFER."

External component operations

You can connect an external component to the AUX (auxiliary) input jack on the control panel.

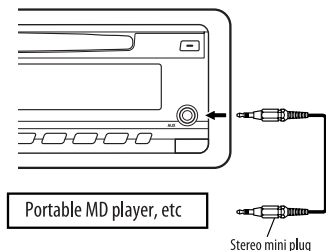

2 Turn on the connected component and start playing the source.

3 Adjust the volume.

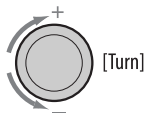

4 Adjust the sound as you want. (See page 13.)

To check other information while listening to an external component



Clock ↔ AUX IN

Maintenance

How to clean the connectors

Frequent detachment will deteriorate the connectors. To minimize this possibility, periodically wipe the connectors with a cotton swab or cloth moistened with alcohol, being careful not to damage the connectors.

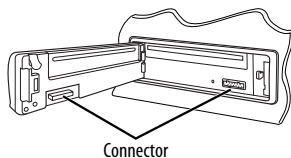

Moisture condensation

Moisture may condense on the lens inside the unit in the following cases:

- After starting the heater in the car.
- If it becomes very humid inside the car.

Should this occur, the unit may malfunction. In this case, eject the disc and leave the unit turned on for a few hours until the moisture evaporates.

How to handle discs

When removing a disc from its case, press down the center holder of the case and lift the disc out, holding it by the edges.

Center holder



- Always hold the disc by the edges. Do not touch its recording surface.

When storing a disc into its case, gently insert the disc around the center holder (with the printed surface facing up).

- Make sure to store discs into the cases after use.

To keep discs clean

A dirty disc may not play correctly. If a disc does become dirty, wipe it with a soft cloth in a straight line from center to edge.



- Do not use any solvent (for example, conventional record cleaner, spray, thinner, benzene, etc.) to clean discs.

To play new discs

New discs may have some rough spots around the inner and outer edges. If such a disc is used, this unit may reject the disc.

To remove these rough spots, rub the edges with a pencil or ball-point pen, etc.



Do not use the following discs:

Warped disc



Sticker



Sticker residue



Stick-on label



Unusual shape



Single CD (8 cm disc)

More about this unit

Basic operations

Turning on the power

- By pressing SRC on the unit, you can also turn on the power. If the source is ready, playback also starts.

Turning off the power

- If you turn off the power while listening to a track, playback starts from where playback it has been stopped previously, next time you turn on the power.

General

- If you change the source while listening to a disc or an iPod, playback stops. Next time you select "CD" or "IPOD" as the playback source, playback starts from where it has been stopped/paused previously.
- After ejecting a disc or disconnecting an iPod, "NO DISC" or "NO IPOD" appears and you cannot operate some of the buttons. Insert another disc, reconnect an iPod, or press SRC to select another playback source.

Tuner operations

Storing stations in memory

- During SSM search...
 - All previously stored stations are erased and stations are stored newly.
 - Received stations are preset in No. 1 (lowest frequency) to No. 6 (highest frequency).
 - When SSM is over, the station stored in No. 1 will be automatically tuned in.
- When storing a station manually, the previously preset station is erased when a new station is stored in the same preset number.

Continued on the next page

Disc operations

Caution for DualDisc playback

- The Non-DVD side of a “DualDisc” does not comply with the “Compact Disc Digital Audio” standard. Therefore, the use of Non-DVD side of a DualDisc on this product may not be recommended.

General

- This unit has been designed to reproduce CDs/CD Texts, and CD-Rs (Recordable)/CD-RWs (Rewritable) in audio CD (CD-DA), MP3 and WMA formats.
- When a disc is inserted upside down, “PLEASE” and “EJECT” appear alternately on the display. Press ▲ to eject the disc.
- MP3 and WMA “tracks” (words “file” and “track” are used interchangeably) are recorded in “folders.”
- While fast-forwarding or reversing on an MP3 or WMA disc, you can only hear intermittent sounds.

Playing a CD-R or CD-RW

- Use only “finalized” CD-Rs or CD-RWs.
- This unit can play back only files of the same type which are first detected if a disc includes both audio CD (CD-DA) files and MP3/WMA files.
- This unit can play back multi-session discs; however, unclosed sessions will be skipped while playing.
- Some CD-Rs or CD-RWs may not play back on this unit because of their disc characteristics, or for the following reasons:
 - Discs are dirty or scratched.
 - Moisture condensation occurs on the lens inside the unit.
 - The pickup lens inside the unit is dirty.
 - CD-R/CD-RW on which the files are written with “Packet Write” method.
 - There are improper recording conditions (missing data, etc.) or media conditions (stained, scratched, warped, etc.).
- CD-RWs may require a longer readout time since the reflectance of CD-RWs is lower than that of regular CDs.

- Do not use the following CD-Rs or CD-RWs:
 - Discs with stickers, labels, or a protective seal stuck to the surface.
 - Discs on which labels can be directly printed by an ink jet printer.
- Using these discs under high temperatures or high humidities may cause malfunctions or damage to the unit.

Playing an MP3/WMA disc

- This unit can play back MP3/WMA files with the extension code <.mp3> or <.wma> (regardless of the letter case—upper/lower).
- This unit can show the names of albums, artists (performer), and Tag (Version 1.0, 1.1, 2.2, 2.3, or 2.4) for MP3 files and for WMA files.
- This unit can display only one-byte characters. No other characters can be correctly displayed.
- This unit can play back MP3/WMA files meeting the conditions below:
 - Bit rate: 8 kbps — 320 kbps
 - Sampling frequency:
 - 48 kHz, 44.1 kHz, 32 kHz (for MPEG-1)
 - 24 kHz, 22.05 kHz, 16 kHz (for MPEG-2)
 - Disc format: ISO 9660 Level 1/Level 2, Romeo, Joliet, Windows long file name
- The maximum number of characters for file/folder names vary among the disc format used (includes 4 extension characters—<.mp3> or <.wma>).
 - ISO 9660 Level 1: up to 12 characters
 - ISO 9660 Level 2: up to 31 characters
 - Romeo: up to 128 characters
 - Joliet: up to 64 characters
 - Windows long file name: up to 128 characters
- This unit can recognize a total of 512 files, of 200 folders, and of 8 hierarchies.
- This unit can play back files recorded in VBR (variable bit rate).

Files recorded in VBR have a discrepancy in elapsed time display, and do not show the actual elapsed time. Especially, after performing the search function, this difference becomes noticeable.

- This unit cannot play back the following files:
 - MP3 files encoded with MP3i and MP3 PRO format.
 - MP3 files encoded in an inappropriate format.
 - MP3 files encoded with Layer 1/2.
 - WMA files encoded with lossless, professional, and voice format.
 - WMA files which are not based upon Windows Media® Audio.
 - WMA files copy-protected with DRM.
 - Files which have the data such as AIFF, ATRAC3, etc.
- The search function works but search speed is not constant.

Ejecting a disc

- If the ejected disc is not removed within 15 seconds, the disc is automatically inserted again into the loading slot to protect it from dust. Playback starts automatically.

iPod operations

Controllable iPod	Software version
iPod with dock connector (3rd Generation)	2.3 or later
iPod with Click Wheel (4th Generation)	3.1 or later
iPod mini	1.4 or later
iPod photo	1.2 or later
iPod nano	1.0 or later
iPod with Video (5th Generation)	1.0 or later

- If your iPod software version is older than those mentioned above, you may not be able to control the iPod properly. Update your iPod to the latest software version before using it with this unit.
 - You can check the software version of your iPod from “About” in the “Setting” menu of the iPod.
 - For details about updating your iPod, visit <<http://www.apple.com>>.

- When you turn on this unit, the iPod is charged through this unit.
- While the iPod is connected, all operations from the iPod are disabled. Perform all operations from this unit.
- While connecting an iPod with Video:
 - No video shows on the iPod's display or the external monitor (only the audio part is available).
 - It is not possible to browse video files on the “Video” menu. (If you connect the iPod during playback or pausing of a video file, resuming playback will not work.)
- iPod shuffle is not controllable.
- You can control the iPod from this unit when “JVC” or “√” appears on the iPod display.
- The songs order displayed on the selecting menu of this unit may differ from the iPod.
- If playback is stopped, select a track from the selecting menu or press ▼.
- The text information may not be displayed correctly.
 - Some characters such as accented letters cannot be shown correctly on the display.
 - Depends on the condition of communication between the iPod and the unit.
- If the text information includes more than 8 characters, it scrolls on the display. This unit can display up to 40 characters.

General settings—PSM

- If you change the “AMP GAIN” setting from “HIGH PWR” to “LOW PWR” while the volume level is set higher than “VOL 30,” the unit automatically changes the volume level to “VOL 30.”

Hierarchical structure of file searching when an iPod is connected

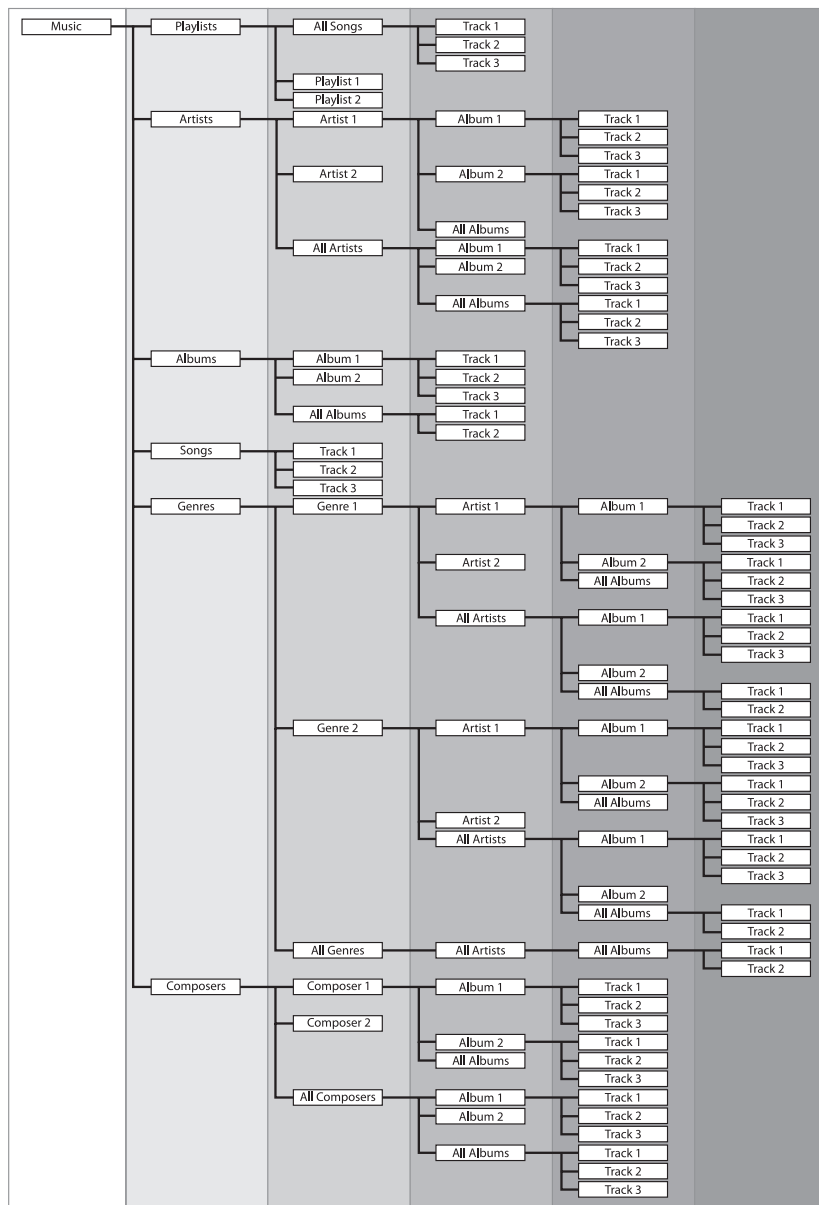

Troubleshooting

What appears to be trouble is not always serious. Check the following points before calling a service center.

	Symptoms	Remedies/Causes
General	• Sound cannot be heard from the speakers.	• Adjust the volume to the optimum level. • Check the cords and connections.
	• The unit does not work at all.	Reset the unit (see page 2).
FM/AM	• SSM automatic presetting does not work.	Store stations manually.
	• Static noise while listening to the radio.	Connect the antenna firmly.
Disc playback	• Disc cannot be played back.	Insert the disc correctly.
	• CD-R/CD-RW cannot be played back. • Tracks on the CD-R/CD-RW cannot be skipped.	• Insert a finalized CD-R/CD-RW. • Finalize the CD-R/CD-RW with the component which you used for recording.
	• Disc can neither be played back nor ejected.	• Unlock the disc (see page 9). • Eject the disc forcibly (see page 2).
	• Disc sound is sometimes interrupted.	• Stop playback while driving on rough roads. • Change the disc. • Check the cords and connections.
	• "NO DISC" appears on the display.	Insert a playable disc into the loading slot.
MP3/WMA playback	• Disc cannot be played back.	• Use a disc with MP3/WMA tracks recorded in the format compliant with ISO 9660 Level 1, Level 2, Romeo, or Joliet. • Add the extension code <.mp3> or <.wma> to the file names.
	• Noise is generated.	Skip to another track or change the disc. (Do not add the extension code <.mp3> or <.wma> to non-MP3 or WMA tracks.)
	• A longer readout time is required ("CHECK" keeps flashing on the display).	Do not use too many hierarchies and folders.

Continued on the next page

	Symptoms	Remedies/Causes
MP3/WMA playback	• Tracks do not play back in the order you have intended them to play.	Playback order is determined when the files are recorded.
	• Elapsed playing time is not correct.	This sometimes occurs during play. This is caused by how the tracks are recorded on the disc.
	• "PLEASE" and "EJECT" appear alternately on the display.	Insert a disc that contains MP3/WMA tracks.
	• Correct characters are not displayed (e.g. album name).	This unit can only display letters (upper case), numbers, and a limited number of symbols.
iPod playback	• The iPod does not turn on or does not work.	<ul style="list-style-type: none"> • Check the connecting cable and its connection. • Update the firmware version. • Charge the battery.
	• The sound is distorted.	Deactivate the equalizer either on the unit or the iPod.
	• "NO IPOD" appears on the display.	<ul style="list-style-type: none"> • Check the connecting cable and its connection. • Charge the battery
	• Playback stops.	The headphones are disconnected during playback. Turn off the unit's power and turn it on again.
	• No sound can be heard when connecting an iPod nano.	<ul style="list-style-type: none"> • Disconnect the headphones from the iPod nano. • Update the firmware version of the iPod nano.
	• "NO FILES" appears on the display.	No tracks are stored. Import tracks to the iPod.
	• "RESET 1" – "RESET 7" appears on the display.	Reconnect the iPod.
	• "RESET 8" appears on the display.	Check the connecting cable and its connection
	• The iPod's controls do not work after disconnecting from this unit.	Reset the iPod.

- Microsoft and Windows Media are either registered trademarks or trademarks of Microsoft Corporation in the United States and/or other countries.
- iPod is a trademark of Apple Computer, Inc., registered in the U.S. and other countries.

Specifications

AUDIO AMPLIFIER SECTION	
Maximum Power Output:	
Front/Rear:	50 W per channel
Continuous Power Output (RMS):	
Front/Rear:	19 W per channel into 4 Ω , 40 Hz to 20 000 Hz at no more than 0.8% total harmonic distortion.
Load Impedance:	4 Ω (4 Ω to 8 Ω allowance)
Tone Control Range:	
Bass:	± 12 dB at 60 Hz
Mid-range:	± 12 dB at 1 kHz
Treble:	± 12 dB at 7.5 kHz
Frequency Response:	40 Hz to 20 000 Hz
Signal-to-Noise Ratio:	70 dB
Line-Out Level/Impedance:	2.5 V/20 k Ω load (full scale)
Subwoofer-Out Level/Impedance:	2.5 V /20 k Ω load (full scale)
Output Impedance:	1 k Ω
Other Terminal:	AUX (auxiliary) input jack, iPod jack

TUNER SECTION	
Frequency Range:	
FM:	87.5 MHz to 108.0 MHz
AM:	531 kHz to 1 602 kHz
FM Tuner	
Usable Sensitivity:	11.3 dBf (1.0 μ V/75 Ω)
50 dB Quieting Sensitivity:	16.3 dBf (1.8 μ V/75 Ω)
Alternate Channel Selectivity (400 kHz):	65 dB
Frequency Response:	40 Hz to 15 000 Hz
Stereo Separation:	30 dB
AM Tuner	
Sensitivity:	20 μ V
Selectivity:	35 dB

CD PLAYER SECTION	
Type:	Compact disc player
Signal Detection System:	Non-contact optical pickup (semiconductor laser)
Number of Channels:	2 channels (stereo)
Frequency Response:	5 Hz to 20 000 Hz
Dynamic Range:	96 dB
Signal-to-Noise Ratio	98 dB
Wow and Flutter:	Less than measurable limit
MP3 Decoding Format: (MPEG1/2 Audio Layer 3)	
Max. Bit Rate:	320 kbps
WMA (Windows Media [®] Audio) Decoding Format:	
Max. Bit Rate:	192 kbps

GENERAL	
Power Requirement:	
Operating Voltage:	DC 14.4 V (11 V to 16 V allowance)
Grounding System:	Negative ground
Allowable Operating Temperature:	0°C to +40°C
Dimensions (W \times H \times D): (approx.)	
Installation Size:	182 mm \times 52 mm \times 150 mm
Panel Size:	187 mm \times 58 mm \times 13 mm
Mass:	1.3 kg (excluding accessories)

Design and specifications are subject to change without notice.

Having TROUBLE with operation?

Please reset your unit

Refer to page of How to reset your unit

หากมีปัญหในการใช้งาน
กรุณาดูปุ่มตั้งค่าเริ่มต้นใหม่
กรุณาดูหน้าวิธีตั้งค่าเครื่องใหม่

JVC



EN, TH

© 2006 Victor Company of Japan, Limited

1206DTSMDTJEIN

JVC KD-PDR35

Installation/Connection Manual

การติดตั้ง/คู่มือการติดตั้ง

GET0468-006A
[U/UH]

1206DTSMDTJEIN
EN, TH

© 2006 Victor Company of Japan, Limited

ENGLISH

This unit is designed to operate on **12 V DC, NEGATIVE ground electrical systems**. If your vehicle does not have this system, a voltage inverter is required, which can be purchased at JVC car audio dealers.

WARNINGS

To prevent short circuits, we recommend that you disconnect the battery's negative terminal and make all electrical connections before installing the unit.

• **Be sure to ground this unit to the car's chassis again after installation.**

Notes:

- Replace the fuse with one of the specified rating. If the fuse blows frequently, consult your JVC car audio dealer.
- It is recommended to connect to the speakers with maximum power of more than 50 W (both at the rear and at the front, with an impedance of **4 Ω to 8 Ω**). If the maximum power is less than 50 W, change "AMP GAIN" setting to prevent the speakers from being damaged (see page 15 of the INSTRUCTIONS).
- To prevent short-circuit, cover the terminals of the UNUSED leads with insulating tape.
- The heat sink becomes very hot after use. Be careful not to touch it when removing this unit.

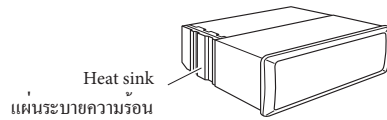

ไทย

ชุดประกอบนี้ได้รับการออกแบบมาเพื่อใช้งานกับระบบ กระแสไฟฟ้าสายดินขั้วลบกระแสตรง **12 โวลต์** หากรถยนต์ของคุณไม่
ได้ใช้ระบบนี้ ต้องใช้เครื่องแปลงกระแสไฟช่วย ซึ่งสามารถหาซื้อได้จากร้านขายเครื่องเสียงรถยนต์ JVC

คำเตือน

เพื่อป้องกันการเกิดไฟฟ้ลัดวงจรขอแนะนำให้ปลั๊กขั้วแบตเตอรี่ลบออกแล้วจึงต่อสายไฟก่อนติดตั้งเครื่อง

- ตรวจสอบให้แน่ใจว่าได้เดินสายดินต่อระหว่างเครื่องกับตัวถัง รถยนต์ใหม่แล้วหลังจากติดตั้ง

หมายเหตุ:

- ใช้ฟิวส์เฉพาะแทนฟิวส์ หากฟิวส์ขาดบ่อย ให้ปรึกษาร้าน ขายเครื่องเสียงรถยนต์ JVC
- ขอแนะนำให้ต่อลำโพง ที่มีกำลังขับสูงสุดเกินกว่า 50 W (ทั้งด้านหน้าและด้านหลัง มีค่าความต้านทาน **4 Ω ถึง 8 Ω**) ถ้ากำลังขับต่ำกว่า 50 W ให้เปลี่ยนค่า "AMP GAIN" เพื่อป้องกันไม่ให้ลำโพงชำรุด (ดูหน้า 15 คำแนะนำ)
- การป้องกันการลัดวงจร จะต้องพันขั้วสายตะกั่ว ที่ไม่ใช้แล้วด้วยเทป ปพันสายไฟ
- แผ่นระบายความร้อนจะร้อนมากหลังจากใช้ ระวังอย่าไป สัมผัสเมื่อถอดชุดประกอบนี้

PRECAUTIONS on power supply and speaker connections:

- **DO NOT connect the speaker leads of the power cord to the car battery; otherwise, the unit will be seriously damaged.**
- BEFORE connecting the speaker leads of the power cord to the speakers, check the speaker wiring in your car.

ข้อควรระวังสำหรับการต่อแหล่งจ่ายกำลังและลำโพง:

- อย่าต่อสายตะกั่วแบตเตอรี่กับลำโพงเข้ากับแบตเตอรี่รถยนต์ มิฉะนั้น ชุดประกอบจะได้รับความเสียหายมาก
- ก่อนที่จะต่อสายตะกั่วแบตเตอรี่ของลำโพงเข้ากับลำโพง ให้ตรวจสอบการเดินสายไฟลำโพงในรถของคุณให้เรียบร้อยเสียก่อน

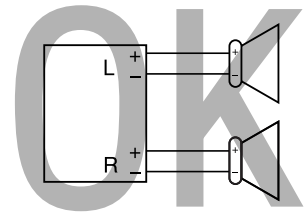
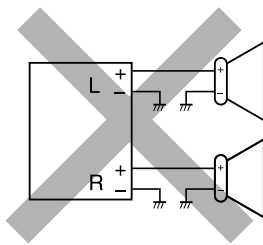
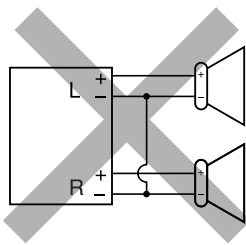

Parts list for installation and connection

The following parts are provided for this unit. If any item is missing, consult your JVC car audio dealer immediately.

รายการส่วนประกอบสำหรับติดตั้งและเชื่อมต่อกัน

ส่วนประกอบต่อไปนี้ให้มาพร้อมกับชุดประกอบนี้ หากมีสิ่งใดไม่ครบ กรุณาปรึกษาตัวแทนจำหน่ายเครื่องเสียงรถยนต์ JVC โดยทันที

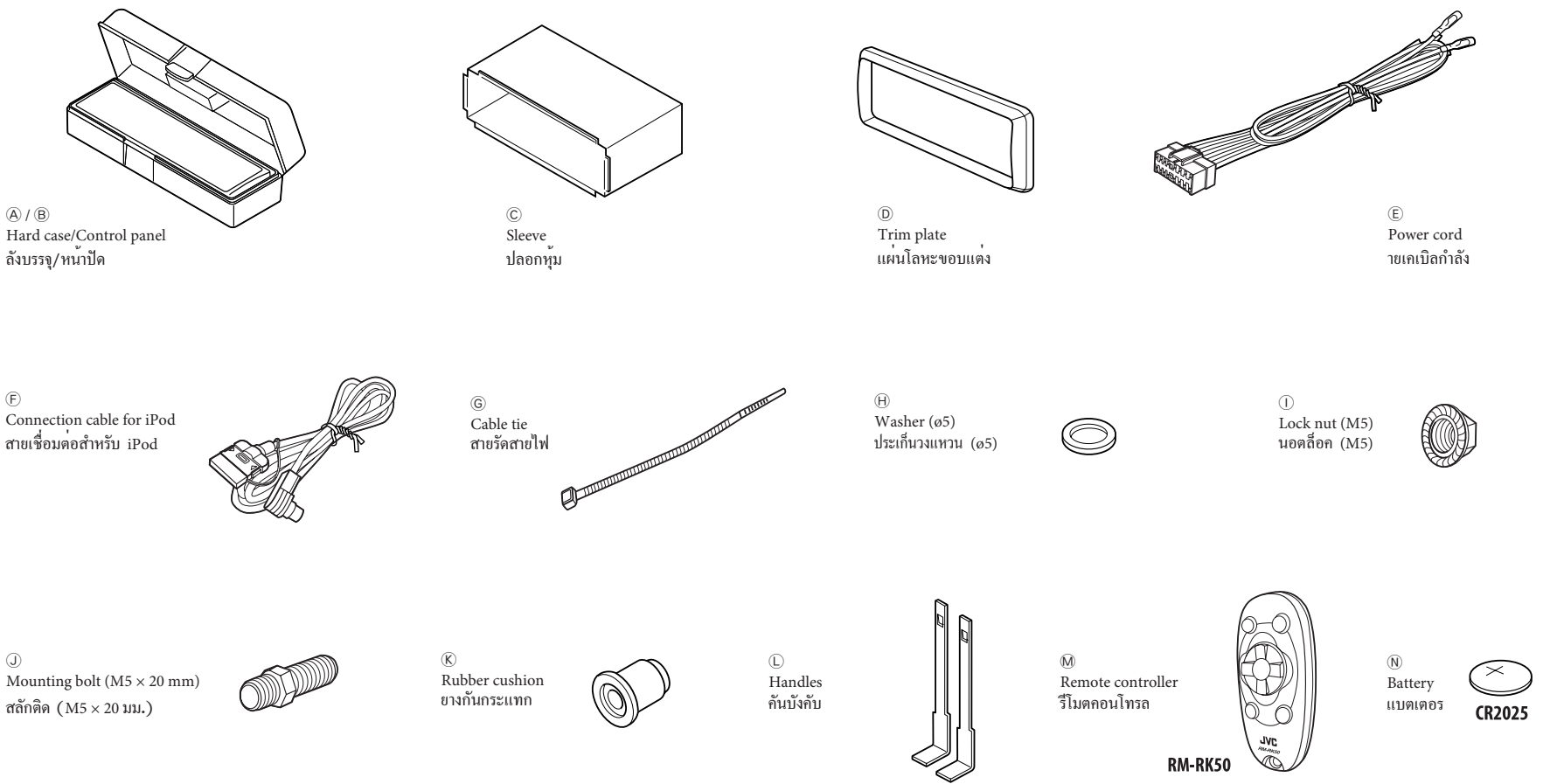

INSTALLATION (IN-DASH MOUNTING)

The following illustration shows a typical installation. If you have any questions or require information regarding installation kits, consult your JVC car audio dealer or a company supplying kits.

- If you are not sure how to install this unit correctly, have it installed by a qualified technician.

การติดตั้ง (การประกอบแผงหน้าปัด)

ภาพตัวอย่างต่อไปนี้แสดงถึงการติดตั้งแบบทั่วไป หากคุณมีข้อสงสัยหรือต้องการข้อมูลเพิ่มเติมเกี่ยวกับชุดติดตั้ง กรุณาปรึกษากับผู้ขายเครื่องเสียงรถยนต์ JVC ของท่านหรือบริษัท

- ชุดประกอบ ถ้าคุณไม่แน่ใจว่าติดตั้งชุดประกอบนี้ถูกต้องหรือไม่ ให้หาช่างผู้เชี่ยวชาญเป็นผู้ติดตั้ง

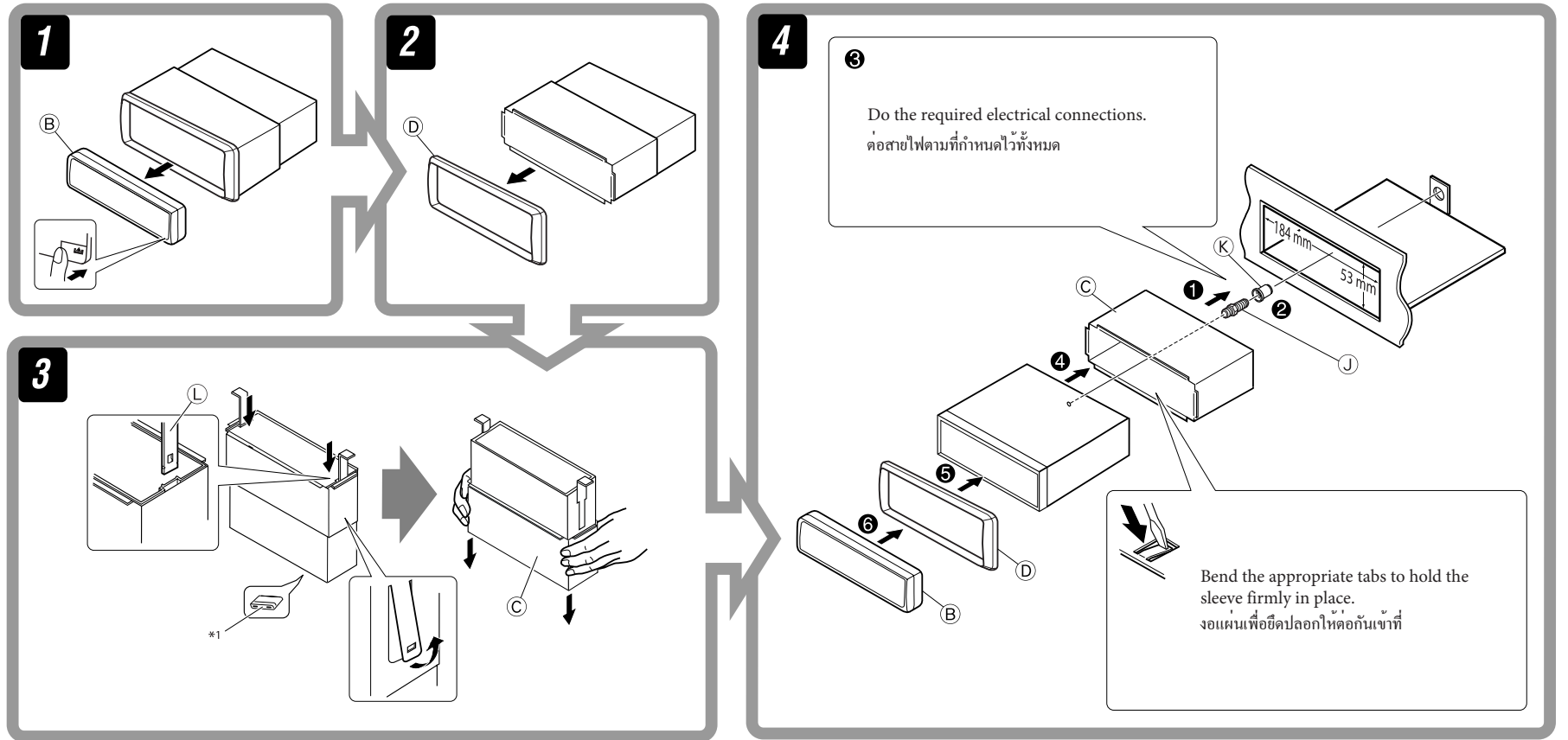

Removing the unit

Before removing the unit, release the rear section.

การถอดชุดประกอบ

ก่อนจะถอดชุดประกอบ ให้ปลดหน้าตัดส่วนท้ายก่อน

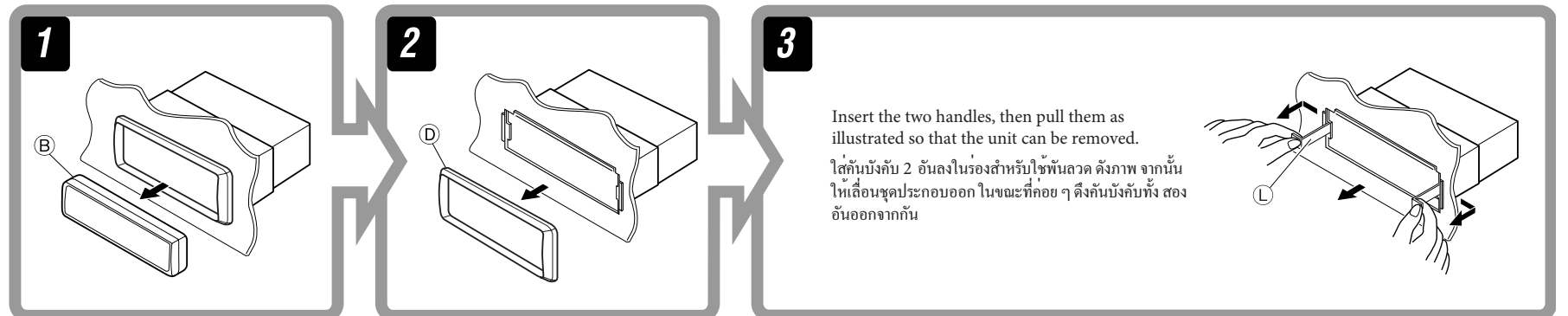

When using the optional stay / เมื่อใช้ตัวยึดแบบเลือกได้

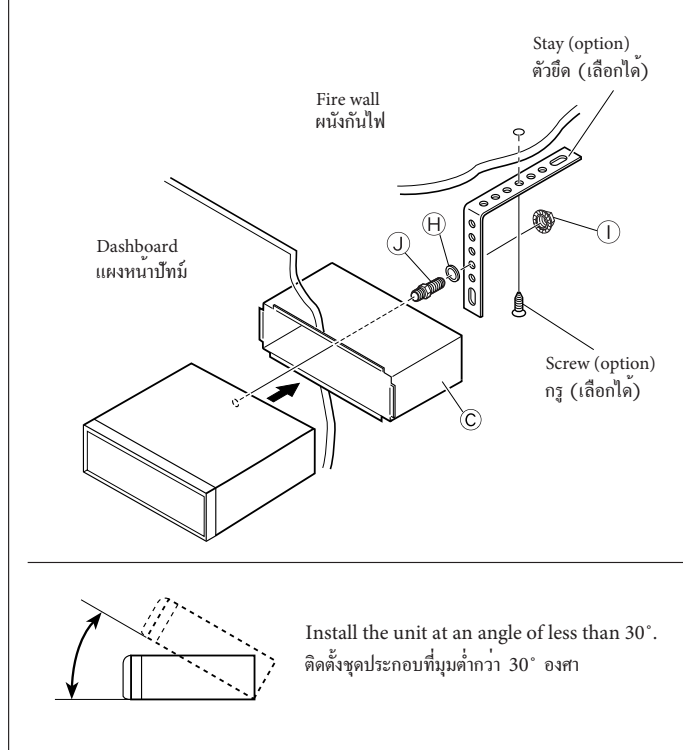

When installing the unit without using the sleeve / เมื่อติดตั้งชุดประกอบโดยไม่ใช้ปลอกหุ้ม

In a Toyota car for example, first remove the car radio and install the unit in its place.

ตัวอย่างเช่น ในรถยนต์โตโยต้า ให้ถอดวิทยุติดรถยนต์ออกก่อน แล้วจึงติดตั้งเครื่องนี้เข้าแทนที่

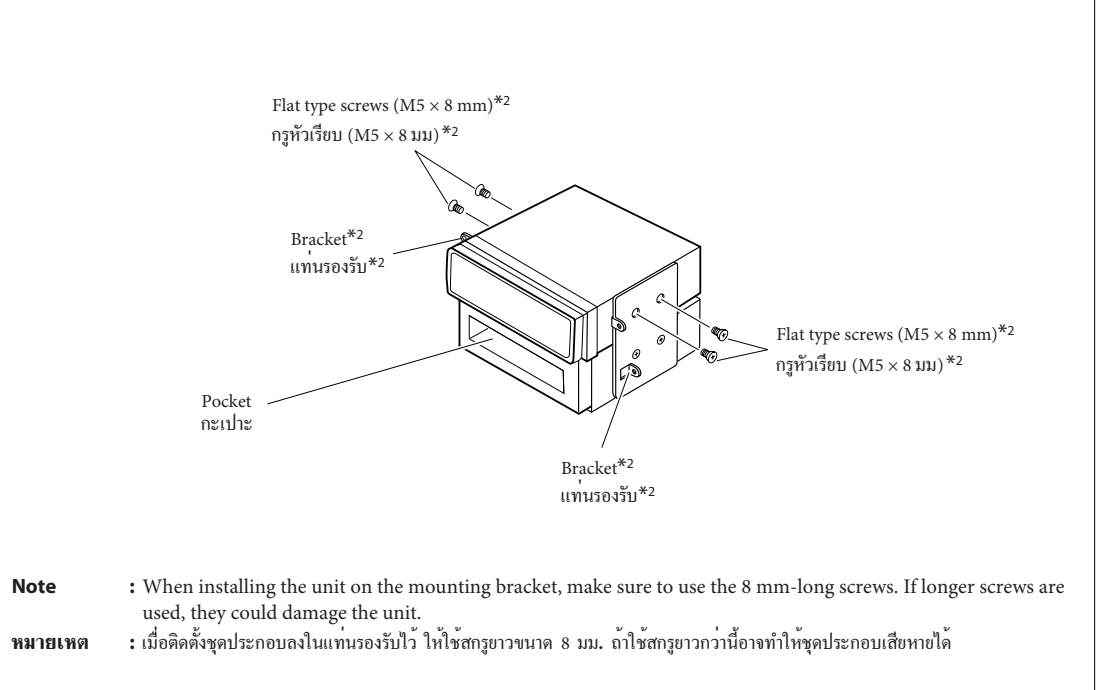

*1 When you stand the unit, be careful not to damage the fuse on the rear.
 *2 Not supplied for this unit.

*1 เมื่อคุณตั้งชุดประกอบขึ้น ระมัดระวังอย่าทำให้ฟิวส์บริเวณส่วนท้ายเสียหาย
 *2 ไม่ได้ให้มากับชุดประกอบนี้

ELECTRICAL CONNECTIONS

การเชื่อมต่อโดยใช้ไฟฟ้า

A Typical connections / การเชื่อมต่อแบบปกติ

Before connecting: Check the wiring in the vehicle carefully. Incorrect connection may cause serious damage to this unit.
The leads of the power cord and those of the connector from the car body may be different in color.

ก่อนทำการเชื่อมต่อ: ตรวจสอบการเดินสายไฟในรถอย่างระมัดระวังอย่างมิให้เกิดความเสียหายต่อชุดอุปกรณ์ที่อาจเชื่อมต่อผิดพลาดอาจทำให้เกิดความเสียหายแก่ชุดอุปกรณ์ที่ติดตั้งได้ตลอดเวลาของ วิทยุ และของอุปกรณ์เชื่อมต่อจากตัวรถ จดจำไว้ ที่ไม่เหมือนกัน

- 1 Connect the colored leads of the power cord in the order specified in the illustration below.
- 2 Connect the antenna cord.
- 3 Finally connect the wiring harness to the unit.

- 1 ต่อสายไฟสีตามลำดับที่ระบุในรูปด้านล่าง
- 2 เชื่อมต่อกับสายอากาศ
- 3 สุดท้าย ต่อส่วนควบคุมการเดินสายไฟเข้ากับชุดประกอบชุดนี้

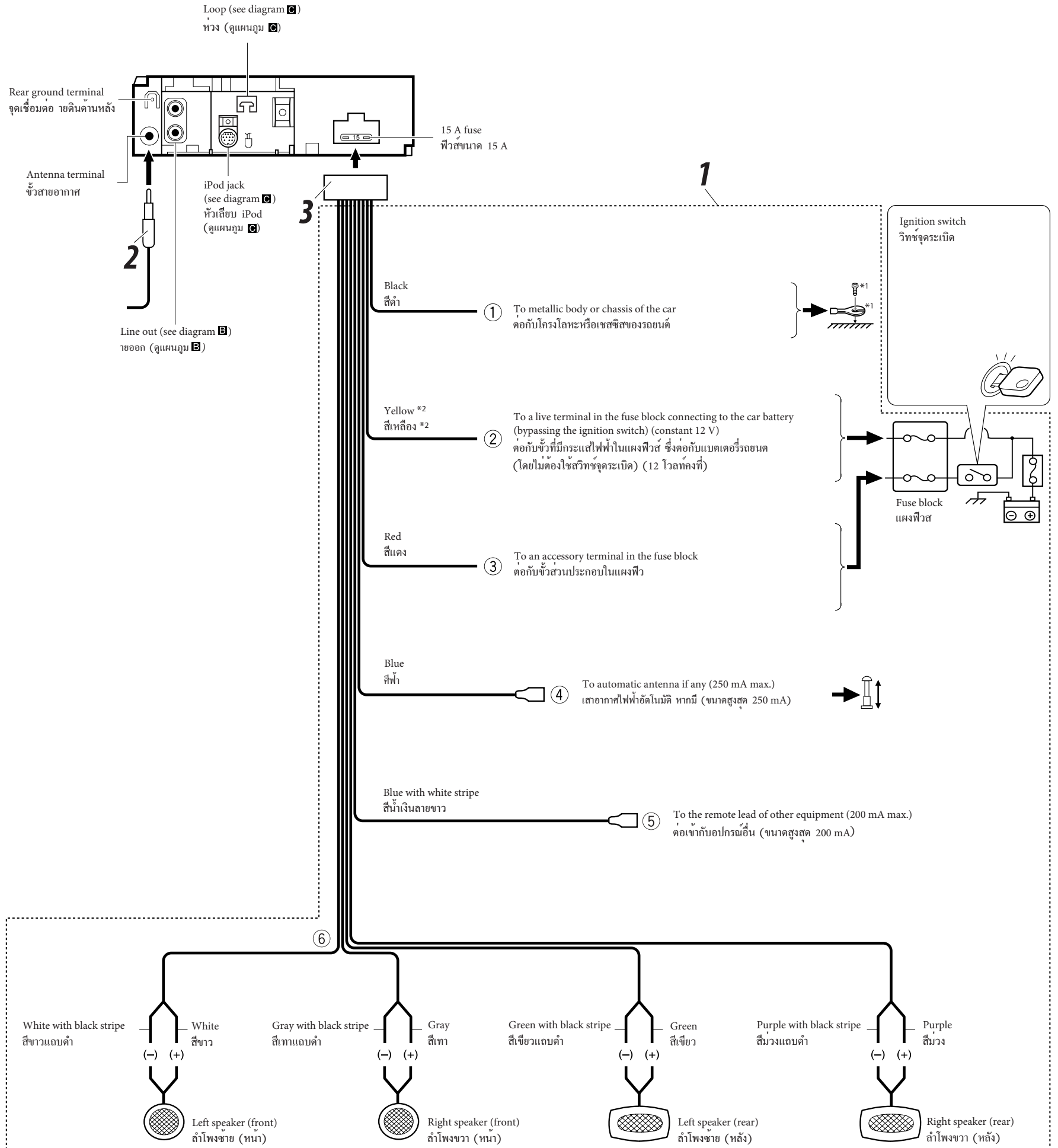

*1 Not supplied for this unit.
*2 Before checking the operation of this unit prior to installation, this lead must be connected, otherwise power cannot be turned on.

*1 ไม่ได้ให้มาพร้อมกับชุดประกอบนี้
*2 ก่อนการตรวจสอบการทำงานของหน่วยก่อนที่ติดตั้ง ต้องต่อสายตะกั่วนี้ก่อนมิฉะนั้นจะไม่สามารถเปิดเครื่องได้

B Connecting the external amplifier or subwoofer / ต่อแอมป์ไฟฟ้าเออร์หรือซับวูฟเฟอร์ค้านอ

You can connect amplifier to upgrade your car stereo system.

- Connect the remote lead (blue with white stripe) to the remote lead of the other equipment so that it can be controlled through this unit.
- **Disconnect the speakers from this unit, connect them to the amplifier. Leave the speaker leads of this unit unused.**

คุณสามารถค้อกับแอมป์ไฟฟ้าเออร์ เพื่อเพิ่มค้ณ ภาพเสียงให้กับระบบสเตอริโอของรถยนต์

- ค้อสายค้กัวระยะไกล (สีน้ำเงินลายขาว) เช้ากับสายค้กัวระยะไกลของอุปกรณ์อื่น ๆ เพื่อจะสามารถควบคุมโดยชุดประค้อบนี้ได้
- ถอดล้าไฟงออกจากรชุดประค้อบนี้ แล้วค้อกับเครื่องขยาย ทั้งสายค้กัวล้าไฟงของชุดประค้อบนี้ไว้

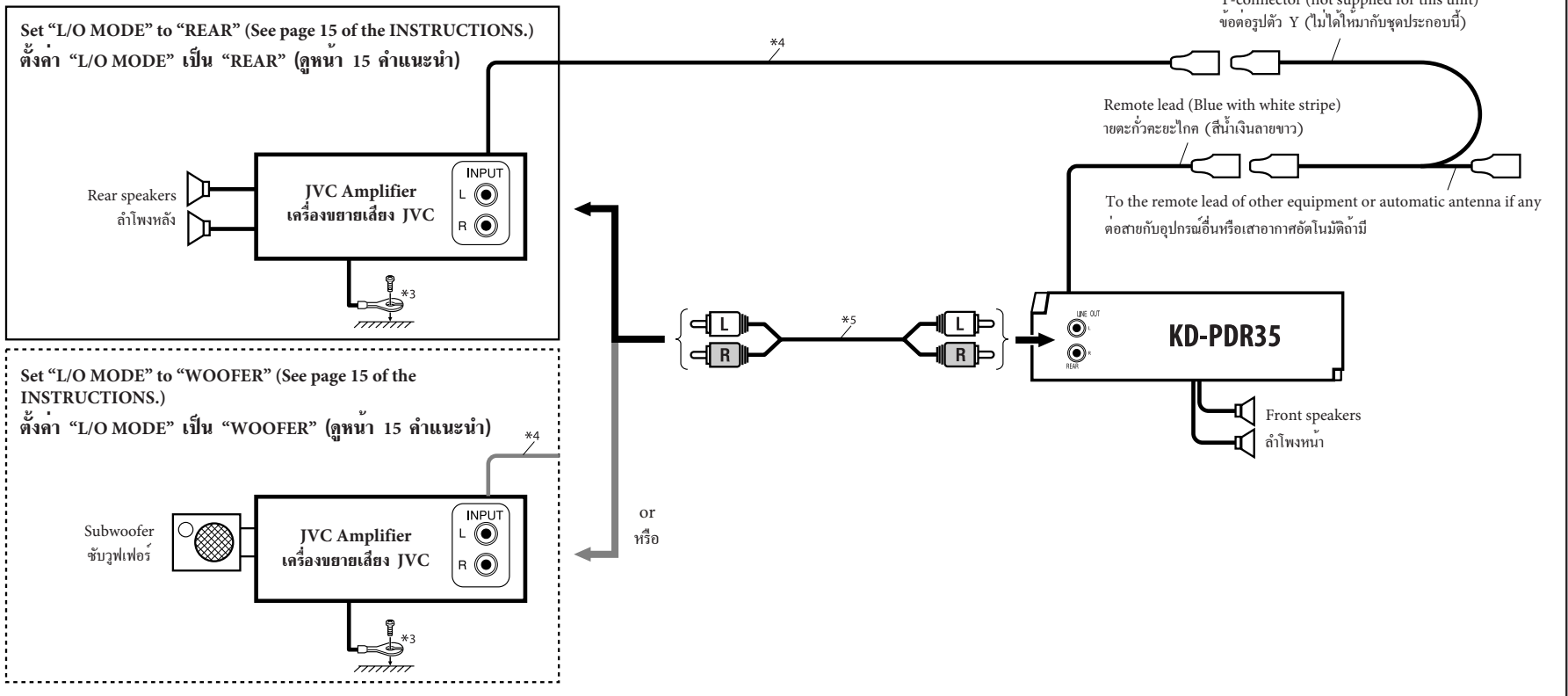

C Connecting an Apple iPod / การเชื่อมต้อกับ Apple iPod

You can connect an iPod to this unit using the supplied connection cable for iPod.

- 1 Insert the supplied cable tie across the loop.
- 2 Press in the head of the connection cable for iPod until you hear a clicking sound.
- 3 Fasten the connection cable using the cable tie to firmly hold the connection cable in place.

ท่านสามารถค้อกับเครื่องเล่น iPod กับเครื่องเล่นนี้ได้โดยใช้สายเคเบิลที่มากับเครื่อง iPod ชิดสายเคเบิลล้าสำหรับ

- 1 สอดสายรัดสายไฟที่ให้มาเข้าไปในห่วง
- 2 กดหัวเสียบสายค้ iPod ลงไปจนกระทั่งได้ยินเสียงค้กัคลิก
- 3 ใช้สายรัดสายไฟที่ค้กัล็อกอยู่กับห่วงยึดสายค้ iPod ไว้ให้อยู่กับที่

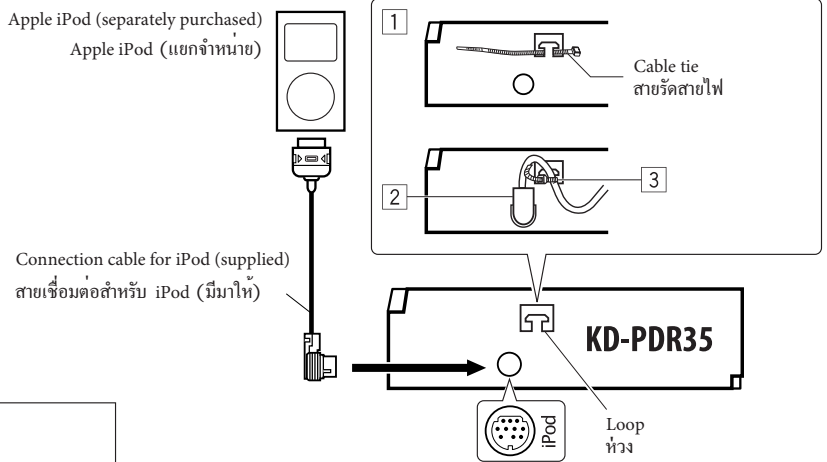

iPod is a trademark of Apple Computer, Inc., registered in the U.S. and other countries.
iPod เป็นเครื่องหมายการค้าของ Apple Computer, Inc. ซึ่งจดทะเบียนการค้าในประค้ทศสหรัฐอเมริกาและประค้ทศอื่น ๆ

*3 Firmly attach the ground wire to the metallic body or to the chassis of the car—to the place uncoated with paint (if coated with paint, remove the paint before attaching the wire). Failure to do so may cause damage to the unit.

*4 Remote lead.

*5 Signal cord (not supplied for this unit).

*3 ค้อกลวดสายดินให้แน่นเข้ากับตัวถังเหล็ก หรือตัวถังรถ—ตรงส่วน ที่ไม่มีสีเคลือบ (หากมีสีเคลือบอยู่ ให้ขูดสีออกก่อน ก่อนค้อกลวดสายดิน) หากไม่ปฏิบัติตามค้าแนะนำนี้ เครื่องอาจชำรุดหรือเสียหายได้

*4 ยค้กัวระยะไกล

*5 ยค้เคเบิลสัญญาณ (ไม่ได้ให้มากับชุดประค้อบนี้)

TROUBLESHOOTING

• The fuse blows.

* Are the red and black leads connected correctly?

• Power cannot be turned on.

* Is the yellow lead connected?

• No sound from the speakers.

* Is the speaker output lead short-circuited?

• Sound is distorted.

* Is the speaker output lead grounded?

* Are the "—" terminals of L and R speakers grounded in common?

• Noise interfere with sounds.

* Is the rear ground terminal connected to the car's chassis using shorter and thicker cords?

• This unit becomes hot.

* Is the speaker output lead grounded?

* Are the "—" terminals of L and R speakers grounded in common?

• This unit does not work at all.

* Have you reset your unit?

การตรวจสอบปัญหาข้ดของ

• ฟิวส์ขาด

* มีการเชื่อม ยค้กัวสีด้าและสีแดงอย่างถูกต้องหรือไม่

• ไม่สามารถเปิดเครื่องได้

* มีการเชื่อมสายค้กัวสีเหลืองหรือไม่

• ไม่มีเสียงออกจากรล้าไฟง

* สายค้กัวส่วนที่ออกทางล้าไฟงเกิดไฟฟ้าล้ค้ดวงจรหรือไม่

• เสียงเพี้ยน

* สายค้กัวส่วนที่ออกทางล้าไฟงค้กัลงดินหรือไม่

* สายขั้วลบ "—" ของล้าไฟงค้านซ้ายและขวาค้กัลงดินตามปกติหรือไม่

• เสียงรบกวน

* มีการใช้สายสั้น ๆ หรือหนา ๆ ค้อกจากรูข้ดส่วนที่ค้ดค้กัไว้บนพื้นด้านหลังกับตัวถังรถยนต์หรือไม่

• ชุดประค้อบร้อนขึ้น

* สายค้กัวส่วนที่ออกทางล้าไฟงค้กัลงดินหรือไม่

* สายขั้วลบ "—" ของล้าไฟงค้านซ้ายและขวาค้กัลงดินตามปกติหรือไม่

• เครื่องรับนี้ทำงานไม่

* ท่านได้ค้กัเครื่องใหม่แล้วหรือข้ก

JVC

CD RECEIVER

KD-PDR35

ENGLISH

INDONESIA

ALAT PENERIMA CD

KD-PDR35

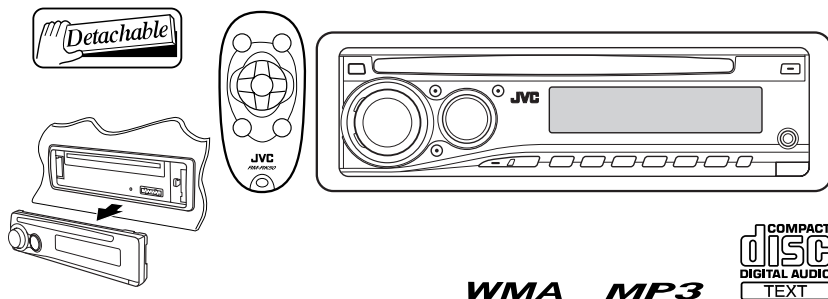

For canceling the display demonstration, see page 6.
Untuk membatalkan tampilan demonstrasi, lihat halaman 6.

For installation and connections, refer to the separate manual.
Untuk instalasi dan penyambungan, lihat buku pedoman terpisah.

INSTRUCTIONS BUKU PETUNJUK

GET0468-004A
[UN]

Thank you for purchasing a JVC product.

Please read all instructions carefully before operation, to ensure your complete understanding and to obtain the best possible performance from the unit.

IMPORTANT FOR LASER PRODUCTS

1. CLASS 1 LASER PRODUCT
2. **CAUTION:** Do not open the top cover. There are no user serviceable parts inside the unit; leave all servicing to qualified service personnel.
3. **CAUTION:** Visible and/or invisible class 1M laser radiation when open. Do not view directly with optical instruments.
4. REPRODUCTION OF LABEL: CAUTION LABEL, PLACED OUTSIDE THE UNIT.

CAUTION VISIBLE AND/OR INVISIBLE CLASS 1M LASER RADIATION WHEN OPEN. DO NOT VIEW DIRECTLY WITH OPTICAL INSTRUMENTS. IEC30065-1:2001 (ENG)	ATTENTION RAYONNEMENT LASER VISIBLE ET/OU INVISIBLE DE CLASSE 1M UNE FOIS OUVERT. NE PAS REGARDER DIRECTEMENT AVEC DES INSTRUMENTS OPTIQUES. (FRA)	AVISO RADIACION LASER DE CLASE 1M VISIBLE Y/O INVISIBLE CUANDO ESTA ABIERTO. NO MIRAR DIRECTAMENTE CON INSTRUMENTAL OPTICO. (ESP)	VARNING SYNLIG OCH/ELLER OSYNLIG LASERSTRÅLNING, KLASS 1M, NÄR DENNA DEL ÄR ÖPPNAD. BETRÄKTA EJ STRÅLEN MED OPTISKA INSTRUMENT. (SWE)	注意 ここを開くと有害 及び/または不可視 のクラス1M レーザー放射が 出ます。 光学機器で直接 見ないでください。 (JPN)	CAUTION VISIBLE AND/OR INVISIBLE CLASS 1 LASER RADIATION WHEN OPEN. DO NOT STARE INTO BEAM. FDA 21 CFR (ENG)
--	--	---	---	--	---



[European Union only]

Warning:

If you need to operate the unit while driving, be sure to look ahead carefully or you may be involved in a traffic accident.

Caution on volume setting:

Discs produce very little noise compared with other sources. Lower the volume before playing a disc to avoid damaging the speakers by the sudden increase of the output level.

How to reset your unit

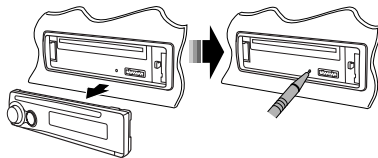

- Your preset adjustments will also be erased.

How to forcibly eject a disc



- Be careful not to drop the disc when it ejects.
- If this does not work, reset your unit.

How to use the M MODE button

If you press M MODE, the unit goes into functions mode, then the number buttons and ▲/▼ buttons work as different function buttons.

Ex.: When number button 2 works as MO (monaural) button.



To use these buttons for their original functions again after pressing M MODE, wait for 5 seconds without pressing any of these buttons until the functions mode is cleared or press M MODE again.

Detaching the control panel

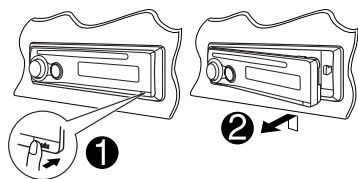

Attaching the control panel

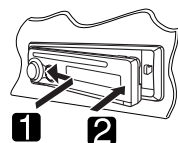

CONTENTS

Control panel	4
Remote controller — RM-RK50.....	5
Getting started.....	6
Basic operations	6
Radio operations	7
Disc operations	8
Playing a disc in the unit	8
iPod operations	11
Sound adjustments.....	13
General settings — PSM	14
External component operations	16
Maintenance	16
More about this unit	17
Troubleshooting	21
Specifications	23

For safety...

- Do not raise the volume level too much, as this will block outside sounds, making driving dangerous.
- Stop the car before performing any complicated operations.

Temperature inside the car...

If you have parked the car for a long time in hot or cold weather, wait until the temperature in the car becomes normal before operating the unit.

Control panel

Parts identification

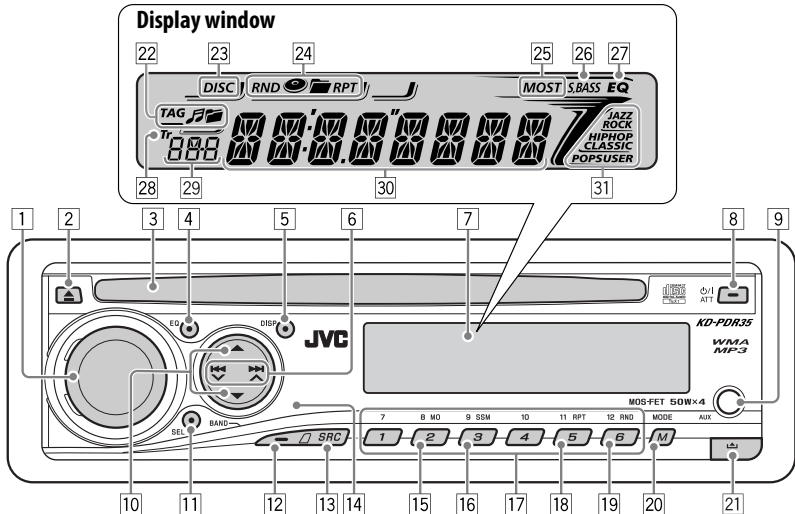

- | | | | |
|----|---|----|---|
| 1 | Control dial | 19 | RND (random) button |
| 2 | ▲ (eject) button | 20 | M MODE button |
| 3 | Loading slot | 21 | ▲ (control panel release) button |
| 4 | EQ (equalizer) button | 22 | Disc information indicators—
TAG (Tag information), 📁 (track/file), 📁 (folder) |
| 5 | DISP (display) button | 23 | DISC indicator |
| 6 | ◀◀ ▶▶ buttons | 24 | Playback mode / item indicators—RND (random),
📁 (disc), 📁 (folder), RPT (repeat) |
| 7 | Display window | 25 | Tuner reception indicators—MO (monaural),
ST (stereo) |
| 8 | ⏻ / ATT (standby/on attenuator) button | 26 | S.BASS (super bass) indicator |
| 9 | AUX (auxiliary) input jack | 27 | EQ (equalizer) indicator |
| 10 | ▲ (up) / ▼ (down) buttons | 28 | Tr (track) indicator |
| 11 | SEL (select) button | 29 | Source display / Time countdown indicator |
| 12 | BAND button | 30 | Main display |
| 13 | SRC (source) button | 31 | Sound mode (iEQ: intelligent equalizer)
indicators—JAZZ, ROCK, HIP HOP, CLASSIC, POPS,
USER |
| 14 | Remote sensor
<i>DO NOT expose the remote sensor to strong light
(direct sunlight or artificial lighting).</i> | | |
| 15 | MO (monaural) button | | |
| 16 | SSM (Strong-station Sequential Memory) button | | |
| 17 | Number buttons | | |
| 18 | RPT (repeat) button | | |

Installing the lithium coin battery (CR2025)

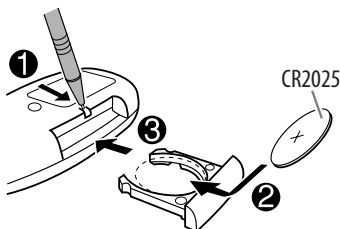

Aim the remote controller directly at the remote sensor on the unit. Make sure there is no obstacle in between.

Warning:

- Do not install any battery other than CR2025 or its equivalent; otherwise, it may explode.
- Do not leave the remote controller in a place (such as dashboards) exposed to direct sunlight for a long time; otherwise, it may explode.
- Store the battery in a place where children cannot reach to avoid risk of accident.
- To prevent the battery from over-heating, cracking, or starting a fire:
 - Do not recharge, short, disassemble, heat the battery, or dispose of it in a fire.
 - Do not leave the battery with other metallic materials.
 - Do not poke the battery with tweezers or similar tools.
 - Wrap the battery with tape and insulate when throwing away or saving it.

Main elements and features

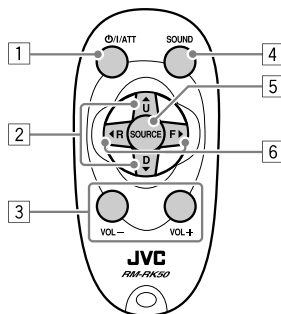

- 1 **⏻ / I/ATT** (standby/on/attenuator) button
 - Turns the power on if pressed briefly or attenuates the sound when the power is on.
 - Turns the power off if pressed and held.
- 2 **▲ U** (up) / **D** (down) **▼** buttons
 - Changes the FM/AM bands with **▲ U**.
 - Changes the preset stations with **D ▼**.
 - Changes the folder of the MP3/WMA discs.
 - While listening to an Apple iPod.
 - Pauses or resumes playback with **D ▼**.
 - Enters the main menu with **▲ U**.
 (Now **▲ U/D ▼/◀ R/F ▶** work as the menu selecting buttons.)*
- 3 **VOL - / VOL +** buttons
 - Adjusts the volume level.
- 4 **SOUND** button
 - Selects the sound mode (iEQ: intelligent equalizer).
- 5 **SOURCE** button
 - Selects the source.

* **▲ U** : Returns to the previous menu.

D ▼ : Confirms the selection.

- 6 ◀ R (reverse) / F (forward) ▶ buttons
- Searches for stations if pressed briefly.
 - Fast-forwards or reverses the track if pressed and held.
 - Changes the tracks if pressed briefly.
 - While listening to an iPod (in menu selecting mode):
 - Selects an item if pressed briefly. (Then, press D ▼ to confirm the selection.)
 - Skips 10 items at a time if pressed and held.

Getting started

Basic operations

1 Turn on the power.



2

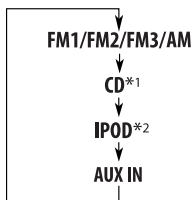

*1 You cannot select "CD" as the playback source if there is no disc in the unit.

*2 "NO IPOD" appears if iPod is not connected.

3 For FM/AM tuner



4 Adjust the volume.

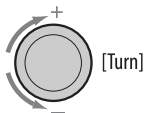

VOL 20

Volume level appears.

5 Adjust the sound as you want. (See page 13.)

To drop the volume in a moment (ATT)

To restore the sound, press the button again.



To turn off the power



Basic settings

- See also "General settings — PSM" on pages 14 and 15.

1



2

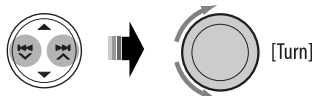

1 Canceling the display demonstrations

Select "DEMO," then "DEMO OFF."

2 Setting the clock

Select "CLOCK H" (hour), then adjust the hour. Select "CLOCK M" (minute), then adjust the minute.

3 Finish the procedure.



To check the current clock time while the power is turned off



Clock time is shown on the display for about 5 seconds. See also page 14.

Radio operations



Lights up when receiving an FM stereo broadcast with sufficient signal strength.



3 Start searching for a station.



When a station is received, searching stops.
To stop searching, press the same button again.

To tune in to a station manually

In step 3 above...



2 Select a desired station frequency.



When an FM stereo broadcast is hard to receive



Lights up when monaural mode is activated.



Reception improves, but stereo effect will be lost.

To restore the stereo effect, repeat the same procedure. "MONO OFF" appears and the MO indicator goes off.

Storing stations in memory

You can preset six stations for each band.

FM station automatic presetting—SSM (Strong-station Sequential Memory)

1 Select the FM band (FM1 – FM3) you want to store into.

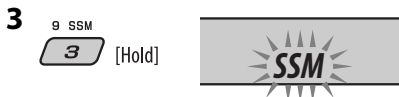





"SSM" flashes, then disappears when automatic presetting is over.

Local FM stations with the strongest signals are searched and stored automatically in the FM band.

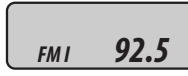

Manual presetting

Ex.: Storing FM station of 92.5 MHz into preset number 4 of the FM1 band.

- 

- 

-  [Hold]
 

Preset number flashes for a while.

Listening to a preset station

- 

- Select the preset station (1 – 6) you want.

7	8 MO	9 SSM	10	11 RPT	12 RND
1	2	3	4	5	6

or



To check other information while listening to the radio



Clock ↔ Frequency

Disc operations

Playing a disc in the unit

All tracks will be played repeatedly until you change the source or eject the disc.

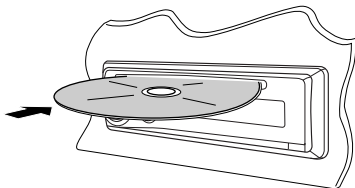

To stop play and eject the disc



- Press SRC to listen to another playback source.

To fast-forward or reverse the track



To go to the next or previous tracks



To go to the next or previous folders (only for MP3 or WMA discs)



To locate a particular track (for CD) or folder (for MP3 or WMA discs) directly

To select a number from 01 – 06:



To select a number from 07 – 12:



[Hold]

- To use direct folder access on MP3/WMA discs, it is required that folders are assigned with 2-digit numbers at the beginning of their folder names—01, 02, 03, and so on.

To select a particular track in a folder (for MP3 or WMA discs):



Other main functions

■ Skipping tracks quickly during play

- For MP3 or WMA discs, you can skip tracks within the same folder.

Ex.: To select track 32 while playing a track whose number is a single digit (1 to 9)

1 MODE
M

2 → Track 1 to 9 → Track 10
..... 30 ← 20 ←

Each time you press the button, you can skip 10 tracks.

- After the last track, the first track will be selected and vice versa.

3 → Track 31 → 32 →

■ Prohibiting disc ejection

You can lock a disc in the loading slot.

SRC + [Hold]



To cancel the prohibition, repeat the same procedure.

Changing the display information



While playing an audio CD or a CD Text

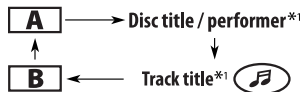

While playing an MP3 or a WMA track

- When "TAG DISP" is set to "TAG ON"
(see page 15)

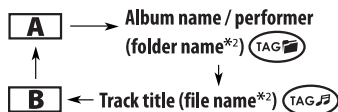

- When "TAG DISP" is set to "TAG OFF"

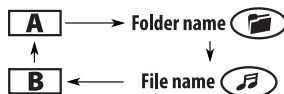

- : Clock with the current track number
 : Elapsed playing time with the current track number
 : Corresponding indicator lights up on the display

*¹ If the current disc is an audio CD, "NO NAME" appears.

*² If an MP3/WMA file does not have Tag information, folder name and file name appear. In this case, the TAG indicator will not light up.

Selecting the playback modes

You can use only one of the following playback modes at a time.

1

2 Select your desired playback mode.

Repeat play 11 RPT

Mode	Plays repeatedly
TRK RPT	: The current track.
FLDR RPT*	: All tracks of the current folder.
RPT OFF	: Cancels.

Random play 12 RND

Mode	Plays at random
FLDR RND*	: All tracks of the current folder, then tracks of the next folder and so on.
DISC RND	: All tracks of the current disc.
RND OFF	: Cancels.

* Only while playing an MP3 or a WMA disc.

: Corresponding indicator lights up on the display

iPod operations

You can play songs from an Apple iPod through this unit by connecting it with the supplied connection cable for iPod.

- Disconnecting the iPod will stop playback. Press SRC to listen to another playback source.
- For connection, see Installation/Connection Manual (separate volume).
- For details, refer also to the manual supplied with your iPod.

1 Connect an iPod.

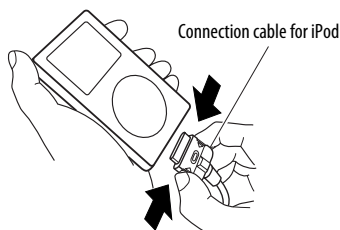

If an iPod has been connected...



Playback starts automatically from where it has been paused previously.

2 Adjust the volume.

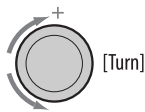

3 Adjust the sound as you want. (See page 13.)

Caution:

- Avoid using the iPod if it might hinder your safety driving.
- Make sure all important data has been backed up to avoid losing the data.

To pause playback



To resume playback, press the button again.

To fast-forward or reverse the track



To go to the next or previous tracks



Selecting a track from the menu

1 Enter the main menu.



Now the ▲/▼/◀/▶/◀◀/▶▶/◀◀◀/▶▶▶ buttons work as the menu selecting buttons*.

2 Select the desired menu.



PLAYLIST ↔ ARTISTS ↔ ALBUMS ↔
SONGS ↔ GENRES ↔ COMPOSER ↔
(back to the beginning)

3 Confirm the selection.



To move back to the previous menu, press ▲.

- If a track is selected, playback starts automatically.
- If the selected item has another layer, you will enter the layer. Repeat steps **2** and **3** until the desired track is played (see page 20).
- Holding ◀◀◀/▶▶▶ can skip 10 items at a time.

- * The menu selecting mode will be canceled:
- If no operations are done for about 5 seconds.
 - When you confirm the selection of a track.

Selecting the playback modes

1



2 Select your desired playback mode.

■ Repeat play

11 RPT

Mode Playback functions (as on iPod)

ONE RPT : Same as "Repeat One."

ALL RPT : Same as "Repeat All."

RPT OFF : Cancels.

■ Random play

12 RND

Mode Playback functions (as on iPod)

ALBM RND* : Same as "Shuffle Albums."

SONG RND : Same as "Shuffle Songs."

RND OFF : Cancels.

* Functions only if you select "ALL" in "ALBUMS" of the main "MENU."

: Corresponding indicator lights up on the display

To check other information while listening to an iPod



Sound adjustments

You can select a preset sound mode suitable to the music genre (iEQ: intelligent equalizer).



Preset values	Indication (For)			
	BAS* ¹	MID* ²	TRE* ³	S.BS* ⁴
USER (Flat sound)	00	00	00	OFF
ROCK (Rock or disco music)	+03	00	+02	ON
CLASSIC (Classical music)	+01	00	+03	OFF
POPS (Light music)	+02	+01	+02	OFF
HIP HOP (Funk or rap music)	+04	-02	+01	ON
JAZZ (Jazz music)	+03	00	+03	OFF

*1 : Bass; *2 : Mid-range; *3 : Treble; *4 : Super bass

Adjusting the sound

You can adjust the sound characteristics to your preference.

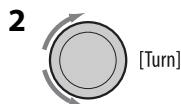
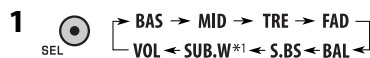

Indication, [Range]

BAS*² (bass), [-06 to +06]

Adjust the bass.

MID*² (mid-range), [-06 to +06]

Adjust the mid-range frequencies sound level.

TRE*² (treble), [-06 to +06]

Adjust the treble.

FAD*³ (fader), [R06 to F06]

Adjust the front and rear speaker balance.

BAL*⁴ (balance), [L06 to R06]

Adjust the left and right speaker balance.

S.BS*² (super bass), [S.BS ON or S.BS OFF], [01 to 05, initial: 03]*⁵

Maintain the richness and fullness of the bass sound regardless of how low you set the volume.

SUB.W*¹ (subwoofer), [00 to 08, initial: 04]

Adjust the subwoofer output level.

VOL (volume), [00 to 30 or 50]*⁶

Adjust the volume.

*1 Displayed only when "L/O MODE" is set to "WOOFER" (see page 15).

*2 When you adjust the bass, mid-range, treble, or super bass, the adjustment you have made is stored for the currently selected sound mode (iEQ) including "USER."

*3 If you are using a two-speaker system, set the fader level to "00."

*4 This adjustment will not affect the subwoofer output.

*5 Range adjustment for super bass is adjustable only when it is set to "S.BS ON."

*6 Depending on the amplifier gain control setting. (See page 15 for details.)

General settings — PSM

You can change PSM (Preferred Setting Mode) items listed in the table that follows.

1  [Hold]

2 Select a PSM item.



3 Adjust the PSM item selected.



4 Repeat steps 2 and 3 to adjust other PSM items if necessary.

5 Finish the procedure.



Indications	Item (__: Initial)	Setting, [reference page]
DEMO Display demonstration	<ul style="list-style-type: none"> • DEMO ON • DEMO OFF 	<ul style="list-style-type: none"> : Display demonstration will be activated automatically if no operation is done for about 20 seconds, [6]. : Cancels.
CLK DISP *1 Clock display	<ul style="list-style-type: none"> • ON • OFF 	<ul style="list-style-type: none"> : Clock time is shown on the display at all times when the power is turned off. : Cancels; pressing DISP will show the clock time for about 5 seconds when the power is turned off, [6].
CLOCK H Hour adjustment	1 – 12	[Initial: 1 (1:00)], [6].
CLOCK M Minute adjustment	00 – 59	[Initial: 00 (1:00)], [6].
DIMMER Dimmer	<ul style="list-style-type: none"> • ON • OFF 	<ul style="list-style-type: none"> : Dims the display illumination. : Cancels.

*1 If the power supply is not interrupted by turning off the ignition key of your car, it is recommended to select "OFF" to save the car's battery.

Indications	Item (__: Initial)	Setting, [reference page]
SCROLL * ² Scroll	<ul style="list-style-type: none"> • ONCE • AUTO • OFF 	<ul style="list-style-type: none"> : Scrolls the track information once. : Repeats scrolling (at 5-second intervals). : Cancels. • Pressing DISP for more than one second can scroll the display regardless of the setting.
L/O MODE Line output mode	<ul style="list-style-type: none"> • REAR • WOOFER 	<ul style="list-style-type: none"> : Select if the REAR LINE OUT terminals are used for connecting the speakers (through an external amplifier). : Select if the REAR LINE OUT terminals are used for connecting a subwoofer (through an external amplifier).
WOOFER * ³ Subwoofer cutoff frequency	<ul style="list-style-type: none"> • LOW • MID • HIGH 	<ul style="list-style-type: none"> : Frequencies lower than 90 Hz are sent to the subwoofer. : Frequencies lower than 135 Hz are sent to the subwoofer. : Frequencies lower than 180 Hz are sent to the subwoofer.
AUX ADJ Auxiliary input level adjustment	A.ADJ 00 — A.ADJ 05	: Adjust the auxiliary input level to avoid the sudden increase of the output level when changing the source from external component connected to the AUX input jack on the control panel.
TAG DISP Tag display	<ul style="list-style-type: none"> • TAG ON • TAG OFF 	<ul style="list-style-type: none"> : Shows the Tag information while playing MP3/WMA tracks, [10]. : Cancels.
AMP GAIN Amplifier gain control	<ul style="list-style-type: none"> • LOW PWR • HIGH PWR 	<ul style="list-style-type: none"> : VOL 00 – VOL 30. (Select this if the maximum power of the speaker is less than 50 W to prevent damaging the speaker.) : VOL 00 – VOL 50.
IF BAND Intermediate frequency band	<ul style="list-style-type: none"> • AUTO • WIDE 	<ul style="list-style-type: none"> : Increases the tuner selectivity to reduce interference noises between close stations. (Stereo effect may be lost.) : Subject to interference noises from adjacent stations, but sound quality will not be degraded and the stereo effect will remain.

*² Some characters or symbols will not be shown correctly (or will be blanked) on the display.

*³ Displayed only when "L/O MODE" is set to "WOOFER."

External component operations

You can connect an external component to the AUX (auxiliary) input jack on the control panel.

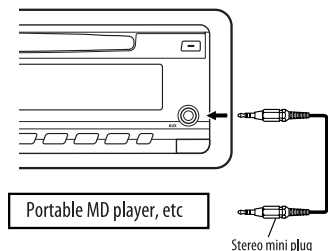

2 Turn on the connected component and start playing the source.

3 Adjust the volume.

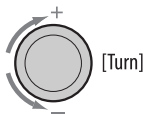

4 Adjust the sound as you want. (See page 13.)

To check other information while listening to an external component



DISP ↔ AUX IN

Maintenance

How to clean the connectors

Frequent detachment will deteriorate the connectors. To minimize this possibility, periodically wipe the connectors with a cotton swab or cloth moistened with alcohol, being careful not to damage the connectors.

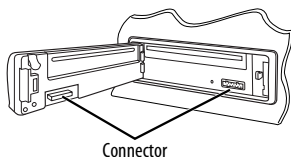

Moisture condensation

Moisture may condense on the lens inside the unit in the following cases:

- After starting the heater in the car.
 - If it becomes very humid inside the car.
- Should this occur, the unit may malfunction. In this case, eject the disc and leave the unit turned on for a few hours until the moisture evaporates.

How to handle discs

When removing a disc from its case, press down the center holder of the case and lift the disc out, holding it by the edges.



- Always hold the disc by the edges. Do not touch its recording surface.

When storing a disc into its case, gently insert the disc around the center holder (with the printed surface facing up).

- Make sure to store discs into the cases after use.

To keep discs clean

A dirty disc may not play correctly. If a disc does become dirty, wipe it with a soft cloth in a straight line from center to edge.



- Do not use any solvent (for example, conventional record cleaner, spray, thinner, benzene, etc.) to clean discs.

To play new discs

New discs may have some rough spots around the inner and outer edges. If such a disc is used, this unit may reject the disc.

To remove these rough spots, rub the edges with a pencil or ball-point pen, etc.



Do not use the following discs:

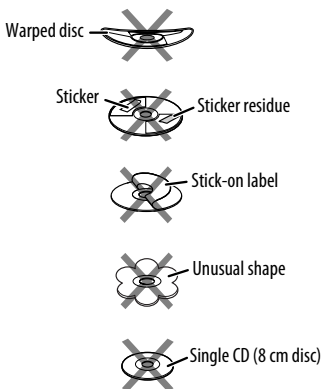

More about this unit

Basic operations

Turning on the power

- By pressing SRC on the unit, you can also turn on the power. If the source is ready, playback also starts.

Turning off the power

- If you turn off the power while listening to a track, playback starts from where playback it has been stopped previously, next time you turn on the power.

General

- If you change the source while listening to a disc or an iPod, playback stops. Next time you select "CD" or "IPOD" as the playback source, playback starts from where it has been stopped/paused previously.
- After ejecting a disc or disconnecting an iPod, "NO DISC" or "NO IPOD" appears and you cannot operate some of the buttons. Insert another disc, reconnect an iPod, or press SRC to select another playback source.

Tuner operations

Storing stations in memory

- During SSM search...
 - All previously stored stations are erased and stations are stored newly.
 - Received stations are preset in No. 1 (lowest frequency) to No. 6 (highest frequency).
 - When SSM is over, the station stored in No. 1 will be automatically tuned in.
- When storing a station manually, the previously preset station is erased when a new station is stored in the same preset number.

Continued on the next page

Disc operations

Caution for DualDisc playback

- The Non-DVD side of a “DualDisc” does not comply with the “Compact Disc Digital Audio” standard. Therefore, the use of Non-DVD side of a DualDisc on this product may not be recommended.

General

- This unit has been designed to reproduce CDs/CD Texts, and CD-Rs (Recordable)/CD-RWs (Rewritable) in audio CD (CD-DA), MP3 and WMA formats.
- When a disc is inserted upside down, “PLEASE” and “EJECT” appear alternately on the display. Press ▲ to eject the disc.
- MP3 and WMA “tracks” (words “file” and “track” are used interchangeably) are recorded in “folders.”
- While fast-forwarding or reversing on an MP3 or WMA disc, you can only hear intermittent sounds.

Playing a CD-R or CD-RW

- Use only “finalized” CD-Rs or CD-RWs.
- This unit can play back only files of the same type which are first detected if a disc includes both audio CD (CD-DA) files and MP3/WMA files.
- This unit can play back multi-session discs; however, unclosed sessions will be skipped while playing.
- Some CD-Rs or CD-RWs may not play back on this unit because of their disc characteristics, or for the following reasons:
 - Discs are dirty or scratched.
 - Moisture condensation occurs on the lens inside the unit.
 - The pickup lens inside the unit is dirty.
 - CD-R/CD-RW on which the files are written with “Packet Write” method.
 - There are improper recording conditions (missing data, etc.) or media conditions (stained, scratched, warped, etc.).
- CD-RWs may require a longer readout time since the reflectance of CD-RWs is lower than that of regular CDs.

- Do not use the following CD-Rs or CD-RWs:
 - Discs with stickers, labels, or a protective seal stuck to the surface.
 - Discs on which labels can be directly printed by an ink jet printer.
- Using these discs under high temperatures or high humidities may cause malfunctions or damage to the unit.

Playing an MP3/WMA disc

- This unit can play back MP3/WMA files with the extension code <.mp3> or <.wma> (regardless of the letter case—upper/lower).
- This unit can show the names of albums, artists (performer), and Tag (Version 1.0, 1.1, 2.2, 2.3, or 2.4) for MP3 files and for WMA files.
- This unit can display only one-byte characters. No other characters can be correctly displayed.
- This unit can play back MP3/WMA files meeting the conditions below:
 - Bit rate: 8 kbps — 320 kbps
 - Sampling frequency:
 - 48 kHz, 44.1 kHz, 32 kHz (for MPEG-1)
 - 24 kHz, 22.05 kHz, 16 kHz (for MPEG-2)
 - Disc format: ISO 9660 Level 1/Level 2, Romeo, Joliet, Windows long file name
- The maximum number of characters for file/folder names vary among the disc format used (includes 4 extension characters—<.mp3> or <.wma>).
 - ISO 9660 Level 1: up to 12 characters
 - ISO 9660 Level 2: up to 31 characters
 - Romeo: up to 128 characters
 - Joliet: up to 64 characters
 - Windows long file name: up to 128 characters
- This unit can recognize a total of 512 files, of 200 folders, and of 8 hierarchies.
- This unit can play back files recorded in VBR (variable bit rate).

Files recorded in VBR have a discrepancy in elapsed time display, and do not show the actual elapsed time. Especially, after performing the search function, this difference becomes noticeable.

- This unit cannot play back the following files:
 - MP3 files encoded with MP3i and MP3 PRO format.
 - MP3 files encoded in an inappropriate format.
 - MP3 files encoded with Layer 1/2.
 - WMA files encoded with lossless, professional, and voice format.
 - WMA files which are not based upon Windows Media® Audio.
 - WMA files copy-protected with DRM.
 - Files which have the data such as AIFF, ATRAC3, etc.
- The search function works but search speed is not constant.

Ejecting a disc

- If the ejected disc is not removed within 15 seconds, the disc is automatically inserted again into the loading slot to protect it from dust. Playback starts automatically.

iPod operations

Controllable iPod	Software version
iPod with dock connector (3rd Generation)	2.3 or later
iPod with Click Wheel (4th Generation)	3.1 or later
iPod mini	1.4 or later
iPod photo	1.2 or later
iPod nano	1.0 or later
iPod with Video (5th Generation)	1.0 or later

- If your iPod software version is older than those mentioned above, you may not be able to control the iPod properly. Update your iPod to the latest software version before using it with this unit.
 - You can check the software version of your iPod from “About” in the “Setting” menu of the iPod.
 - For details about updating your iPod, visit <<http://www.apple.com>>.

- When you turn on this unit, the iPod is charged through this unit.
- While the iPod is connected, all operations from the iPod are disabled. Perform all operations from this unit.
- While connecting an iPod with Video:
 - No video shows on the iPod’s display or the external monitor (only the audio part is available).
 - It is not possible to browse video files on the “Video” menu. (If you connect the iPod during playback or pausing of a video file, resuming playback will not work.)
- iPod shuffle is not controllable.
- You can control the iPod from this unit when “JVC” or “✓” appears on the iPod display.
- The songs order displayed on the selecting menu of this unit may differ from the iPod.
- If playback is stopped, select a track from the selecting menu or press ▼.
- The text information may not be displayed correctly.
 - Some characters such as accented letters cannot be shown correctly on the display.
 - Depends on the condition of communication between the iPod and the unit.
- If the text information includes more than 8 characters, it scrolls on the display. This unit can display up to 40 characters.

General settings—PSM

- If you change the “AMP GAIN” setting from “HIGH PWR” to “LOW PWR” while the volume level is set higher than “VOL 30,” the unit automatically changes the volume level to “VOL 30.”

Hierarchical structure of file searching when an iPod is connected

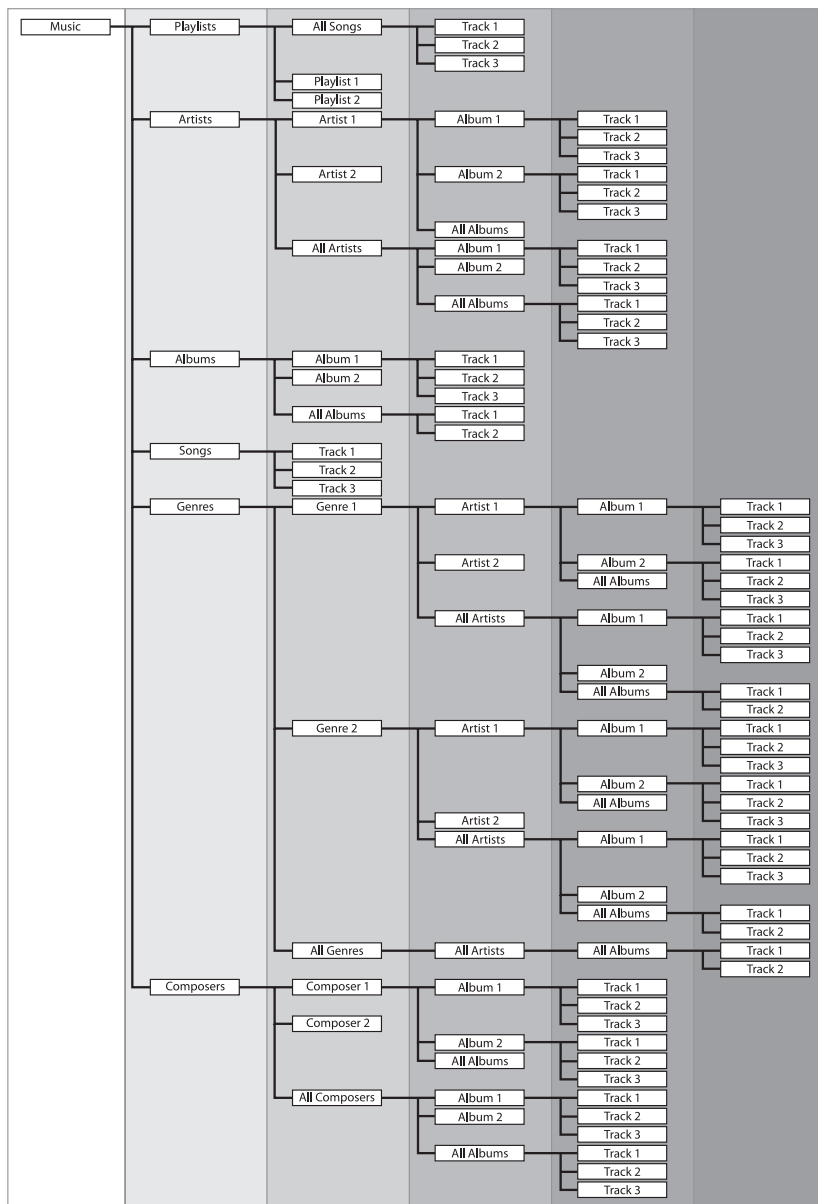

Troubleshooting

What appears to be trouble is not always serious. Check the following points before calling a service center.

	Symptoms	Remedies/Causes
General	<ul style="list-style-type: none"> • Sound cannot be heard from the speakers. 	<ul style="list-style-type: none"> • Adjust the volume to the optimum level. • Check the cords and connections.
	<ul style="list-style-type: none"> • The unit does not work at all. 	Reset the unit (see page 2).
FM/AM	<ul style="list-style-type: none"> • SSM automatic presetting does not work. 	Store stations manually.
	<ul style="list-style-type: none"> • Static noise while listening to the radio. 	Connect the antenna firmly.
Disc playback	<ul style="list-style-type: none"> • Disc cannot be played back. 	Insert the disc correctly.
	<ul style="list-style-type: none"> • CD-R/CD-RW cannot be played back. • Tracks on the CD-R/CD-RW cannot be skipped. 	<ul style="list-style-type: none"> • Insert a finalized CD-R/CD-RW. • Finalize the CD-R/CD-RW with the component which you used for recording.
	<ul style="list-style-type: none"> • Disc can neither be played back nor ejected. 	<ul style="list-style-type: none"> • Unlock the disc (see page 9). • Eject the disc forcibly (see page 2).
	<ul style="list-style-type: none"> • Disc sound is sometimes interrupted. 	<ul style="list-style-type: none"> • Stop playback while driving on rough roads. • Change the disc. • Check the cords and connections.
	<ul style="list-style-type: none"> • "NO DISC" appears on the display. 	Insert a playable disc into the loading slot.
MP3/WMA playback	<ul style="list-style-type: none"> • Disc cannot be played back. 	<ul style="list-style-type: none"> • Use a disc with MP3/WMA tracks recorded in the format compliant with ISO 9660 Level 1, Level 2, Romeo, or Joliet. • Add the extension code <.mp3> or <.wma> to the file names.
	<ul style="list-style-type: none"> • Noise is generated. 	Skip to another track or change the disc. (Do not add the extension code <.mp3> or <.wma> to non-MP3 or WMA tracks.)
	<ul style="list-style-type: none"> • A longer readout time is required ("CHECK" keeps flashing on the display). 	Do not use too many hierarchies and folders.

Continued on the next page

	Symptoms	Remedies/Causes
MP3/WMA playback	• Tracks do not play back in the order you have intended them to play.	Playback order is determined when the files are recorded.
	• Elapsed playing time is not correct.	This sometimes occurs during play. This is caused by how the tracks are recorded on the disc.
	• "PLEASE" and "EJECT" appear alternately on the display.	Insert a disc that contains MP3/WMA tracks.
	• Correct characters are not displayed (e.g. album name).	This unit can only display letters (upper case), numbers, and a limited number of symbols.
iPod playback	• The iPod does not turn on or does not work.	<ul style="list-style-type: none"> • Check the connecting cable and its connection. • Update the firmware version. • Charge the battery.
	• The sound is distorted.	Deactivate the equalizer either on the unit or the iPod.
	• "NO IPOD" appears on the display.	<ul style="list-style-type: none"> • Check the connecting cable and its connection. • Charge the battery
	• Playback stops.	The headphones are disconnected during playback. Turn off the unit's power and turn it on again.
	• No sound can be heard when connecting an iPod nano.	<ul style="list-style-type: none"> • Disconnect the headphones from the iPod nano. • Update the firmware version of the iPod nano.
	• "NO FILES" appears on the display.	No tracks are stored. Import tracks to the iPod.
	• "RESET 1" – "RESET 7" appears on the display.	Reconnect the iPod.
	• "RESET 8" appears on the display.	Check the connecting cable and its connection
	• The iPod's controls do not work after disconnecting from this unit.	Reset the iPod.

- Microsoft and Windows Media are either registered trademarks or trademarks of Microsoft Corporation in the United States and/or other countries.
- iPod is a trademark of Apple Computer, Inc., registered in the U.S. and other countries.

Specifications

AUDIO AMPLIFIER SECTION	
Maximum Power Output:	
Front/Rear:	50 W per channel
Continuous Power Output (RMS):	
Front/Rear:	19 W per channel into 4 Ω , 40 Hz to 20 000 Hz at no more than 0.8% total harmonic distortion.
Load Impedance:	4 Ω (4 Ω to 8 Ω allowance)
Tone Control Range:	
Bass:	± 12 dB at 60 Hz
Mid-range:	± 12 dB at 1 kHz
Treble:	± 12 dB at 7.5 kHz
Frequency Response:	40 Hz to 20 000 Hz
Signal-to-Noise Ratio:	70 dB
Line-Out Level/Impedance:	2.5 V/20 k Ω load (full scale)
Subwoofer-Out Level/Impedance:	2.5 V/20 k Ω load (full scale)
Output Impedance:	1 k Ω
Other Terminal:	AUX (auxiliary) input jack, iPod jack

TUNER SECTION	
Frequency Range:	
FM:	87.5 MHz to 108.0 MHz
AM:	531 kHz to 1 602 kHz
FM Tuner	
Usable Sensitivity:	11.3 dBf (1.0 μ V/75 Ω)
50 dB Quietening Sensitivity:	16.3 dBf (1.8 μ V/75 Ω)
Alternate Channel Selectivity (400 kHz):	65 dB
Frequency Response:	40 Hz to 15 000 Hz
Stereo Separation:	30 dB
AM Tuner	
Sensitivity:	20 μ V
Selectivity:	35 dB

CD PLAYER SECTION	
Type:	Compact disc player
Signal Detection System:	Non-contact optical pickup (semiconductor laser)
Number of Channels:	2 channels (stereo)
Frequency Response:	5 Hz to 20 000 Hz
Dynamic Range:	96 dB
Signal-to-Noise Ratio	98 dB
Wow and Flutter:	Less than measurable limit
MP3 Decoding Format: (MPEG1/2 Audio Layer 3)	
Max. Bit Rate:	320 kbps
WMA (Windows Media [®] Audio) Decoding Format:	
Max. Bit Rate:	192 kbps

GENERAL	
Power Requirement:	
Operating Voltage:	DC 14.4 V (11 V to 16 V allowance)
Grounding System:	Negative ground
Allowable Operating Temperature:	0°C to +40°C
Dimensions (W \times H \times D): (approx.)	
Installation Size:	182 mm \times 52 mm \times 150 mm
Panel Size:	187 mm \times 58 mm \times 13 mm
Mass:	1.3 kg (excluding accessories)

Design and specifications are subject to change without notice.

Having TROUBLE with operation?

Please reset your unit

Refer to page of How to reset your unit

**Ada MASALAH dengan cara
pengoperasian?**

Setel kembali unit Anda

Lihat halaman mengenai Bagaimana mereset unit anda

JVC



EN, IN

© 2006 Victor Company of Japan, Limited

1206DTSMdTJEIN

JVC KD-PDR35

Installation/Connection Manual

Manual Pemasangan/Penyambungan

GET0468-009A
[UN]

1206DTSMDTJEIN
EN, IN

© 2006 Victor Company of Japan, Limited

ENGLISH

This unit is designed to operate on **12 V DC, NEGATIVE ground electrical systems**. If your vehicle does not have this system, a voltage inverter is required, which can be purchased at JVC car audio dealers.

WARNINGS

To prevent short circuits, we recommend that you disconnect the battery's negative terminal and make all electrical connections before installing the unit.

- **Be sure to ground this unit to the car's chassis again after installation.**

Notes:

- Replace the fuse with one of the specified rating. If the fuse blows frequently, consult your JVC car audio dealer.
- It is recommended to connect to the speakers with maximum power of more than 50 W (both at the rear and at the front, with an impedance of **4 Ω to 8 Ω**). If the maximum power is less than 50 W, change "AMP GAIN" setting to prevent the speakers from being damaged (see page 15 of the INSTRUCTIONS).
- To prevent short-circuit, cover the terminals of the UNUSED leads with insulating tape.
- The heat sink becomes very hot after use. Be careful not to touch it when removing this unit.

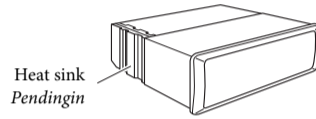

INDONESIA

Alat penerima ini didisain untuk beroperasi hanya pada **12 V DC, sistem listrik tanah NEGATIVE**. Jika kendaraan anda tidak memiliki sistem ini, sebuah pembalik tegangan diperlukan, yang mana dapat dibeli di penyalur-penyalur audio mobil JVC.

PERINGATAN

Untuk mencegah hubungan pendek, kami menyarankan anda memutuskan sambungan terminal negatif baterai dan membuat semua sambungan-sambungan listrik sebelum memasang alat penerima.

- **Pastikan untuk mentanahkan alat penerima ini ke casis mobil kembali setelah pemasangan.**

Catatan:

- Ganti sekering dengan voltase yang sudah ditetapkan. Jika sekering sering meledak, konsultasikan pada penyalur audio mobil JVC anda.
- Disarankan untuk menghubungkan speaker-speaker dengan maksimum power lebih dari 50 W (keduanya di belakang dan di depan, dengan sebuah impedansi **4 Ω sampai 8 Ω**). Jika maksimum power kurang dari 50 W, ganti pengaturan "AMP GAIN" ("PENAMBAH PENGUAT") untuk mencegah speaker-speaker dari kerusakan (lihat halaman 15 dari BUKU PETUNJUK).
- Untuk mencegah hubungan pendek, tutup ujung-ujung terminal-terminal TIDAK DIGUNAKAN dengan pita isolasi.
- Pendingin menjadi sangat panas setelah digunakan. Hati-hati untuk tidak menyentuhnya ketika memindahkan alat penerima ini.

PRECAUTIONS on power supply and speaker connections:

- **DO NOT connect the speaker leads of the power cord to the car battery; otherwise, the unit will be seriously damaged.**
- BEFORE connecting the speaker leads of the power cord to the speakers, check the speaker wiring in your car.

TINDAKAN-TINDAKAN PENCEGAHAN pada suplai power dan sambungan-sambungan speaker:

- **JANGAN sambungkan ujung-ujung speaker dari kabel power ke baterai mobil; sebaliknya, alat penerima tersebut akan secara serius rusak.**
- **SEBELUM menyambung ujung-ujung speaker dari kabel power ke speaker-speaker, cek perkabelan speaker dalam mobil anda.**

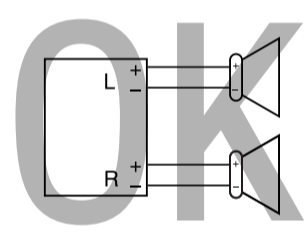
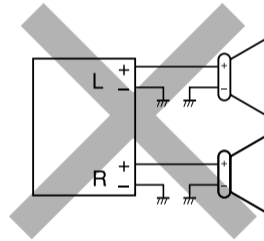
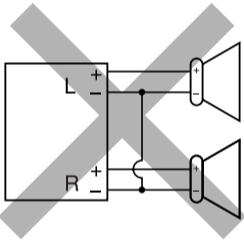

Parts list for installation and connection

The following parts are provided for this unit. If any item is missing, consult your JVC car audio dealer immediately.

Daftar bagian-bagian untuk pemasangan dan penyambungan

Bagian-bagian berikut disediakan untuk alat penerima ini. Jika ada bagian yang hilang, segera hubungi dealer audio mobil JVC anda.

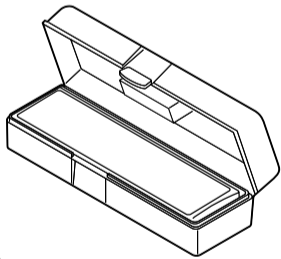

(A / B)
Hard case/Control panel
Kotak keras/Panel kontrol

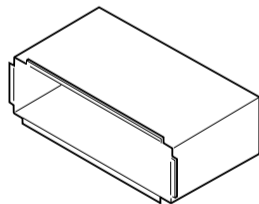

(C)
Sleeve
Selongsong

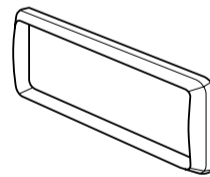

(D)
Trim plate
Plat rapi

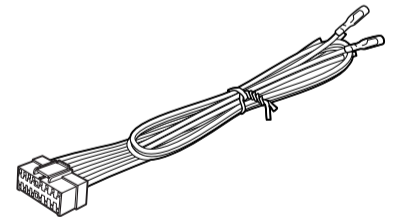

(E)
Power cord
Kabel power

(F)
Connection cable for iPod
Kabel koneksi untuk iPod

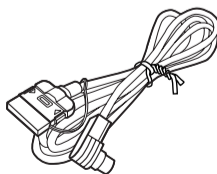

(G)
Cable tie
Ikat kable

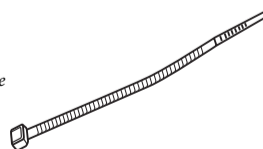

(H)
Washer (ø5)
Perapat sambungan (ø5)



(I)
Lock nut (M5)
Mur kunci (M5)



(J)
Mounting bolt (M5 × 20 mm)
Baut bingkai (M5 × 20 mm)



(K)
Rubber cushion
Bantalan karet



(L)
Handles
Pegangan-pegangan



(M)
Remote controller
Pengontrol jauh

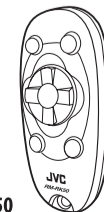

(N)
Battery
Baterai



RM-RK50

CR2025

INSTALLATION (IN-DASH MOUNTING)

The following illustration shows a typical installation. If you have any questions or require information regarding installation kits, consult your JVC car audio dealer or a company supplying kits.

- If you are not sure how to install this unit correctly, have it installed by a qualified technician.

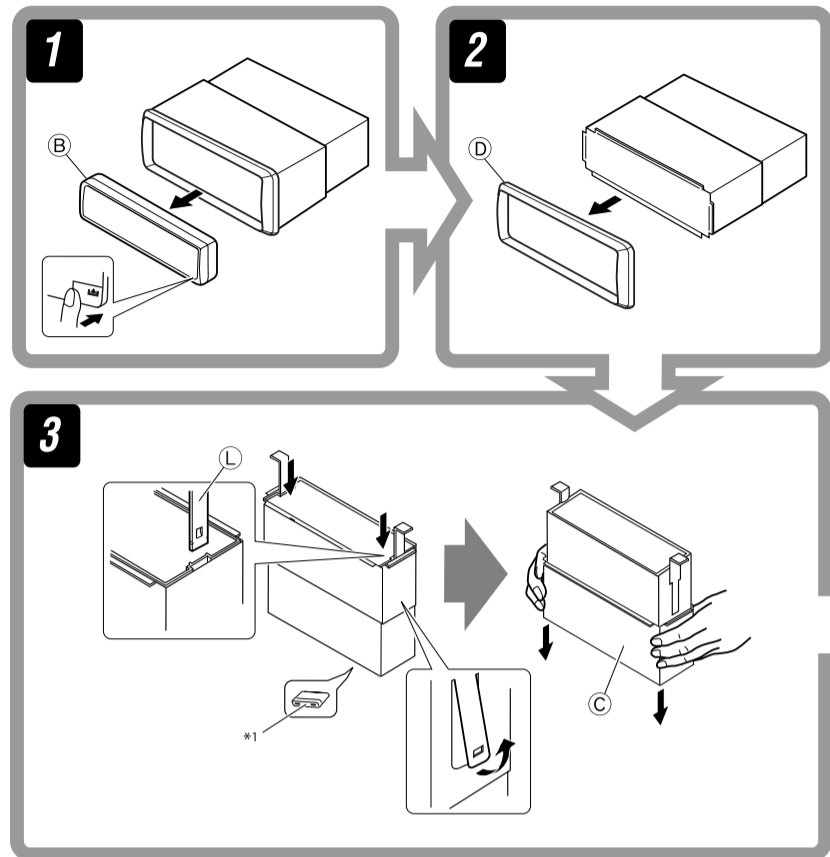

PEMASANGAN (BINGKAI-DALAM DASH)

Ilustrasi berikut menunjukkan sebuah tipe pemasangan. Jika anda mempunyai suatu pertanyaan atau informasi yang diperlukan mengenai alat-alat pemasangan, konsultasikan pada penyalur audio mobil JVC atau sebuah perusahaan yang mensuplai alat-alat.

- Jika anda tidak yakin bagaimana memasang alat penerima ini dengan benar, biarkan dipasang dengan teknisi yang berkualitas.

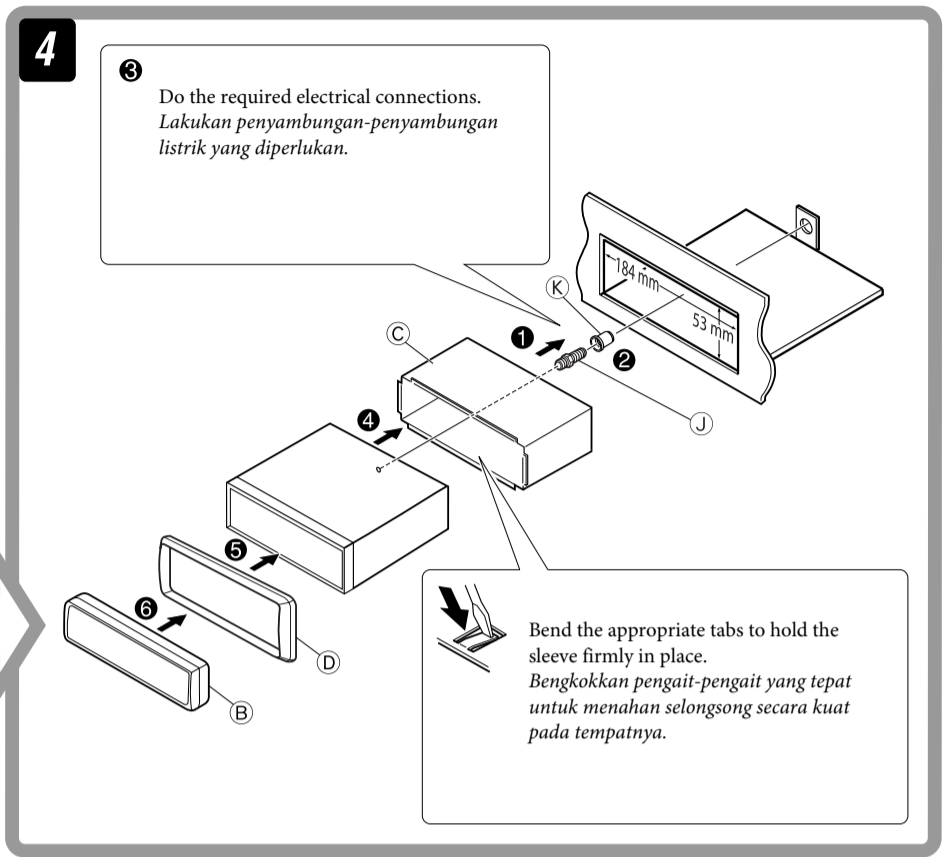

Removing the unit

Before removing the unit, release the rear section.

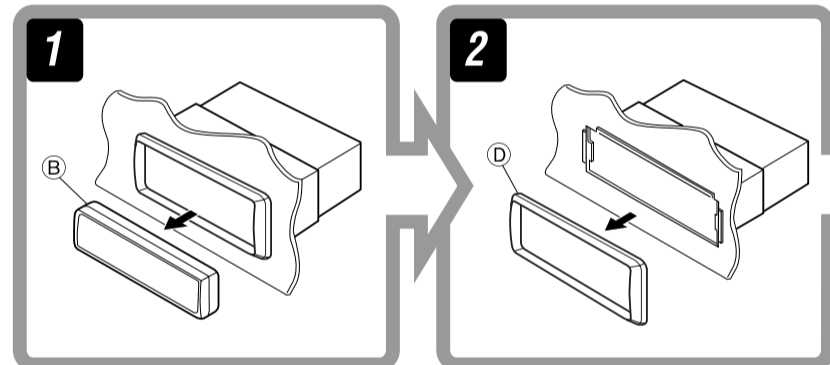

Memindahkan alat penerima

Sebelum memindahkan alat penerima, lepaskan seksi belakang.

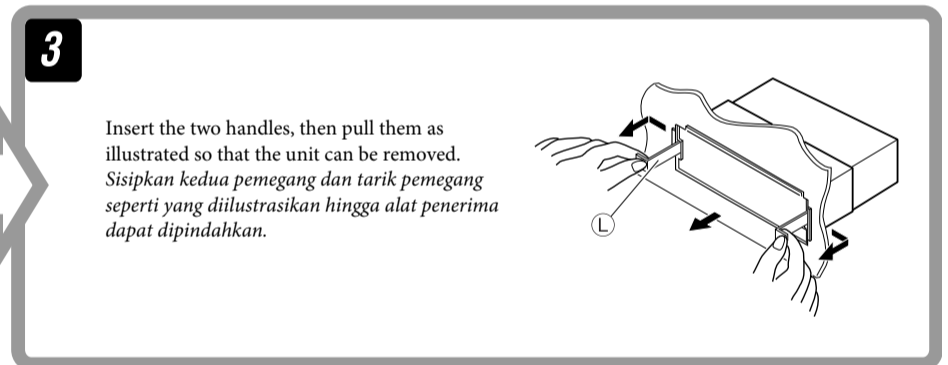

When using the optional stay / Ketika menggunakan penguat tambahan

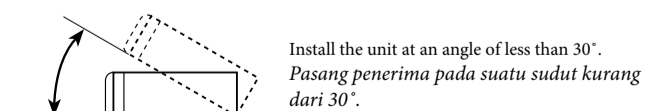
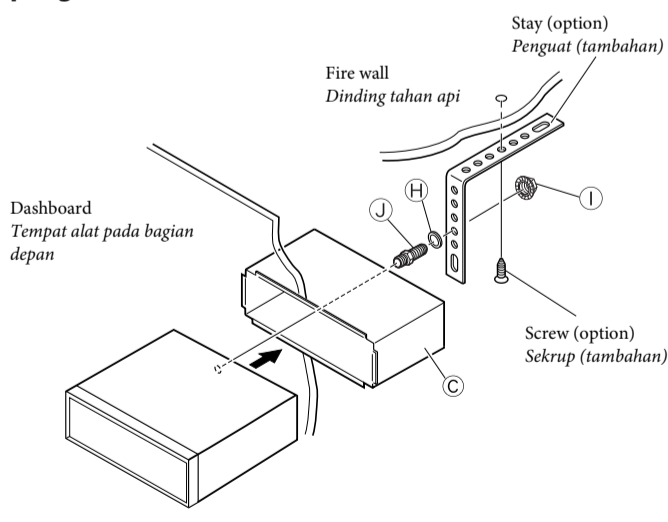

When installing the unit without using the sleeve / Ketika memasang alat penerima tanpa menggunakan selongsong

In a Toyota car for example, first remove the car radio and install the unit in its place.
Dalam sebuah kereta Toyota misalnya, pertama pindahkan radio mobil dan pasang alat penerima tersebut ke dalam tempatnya.

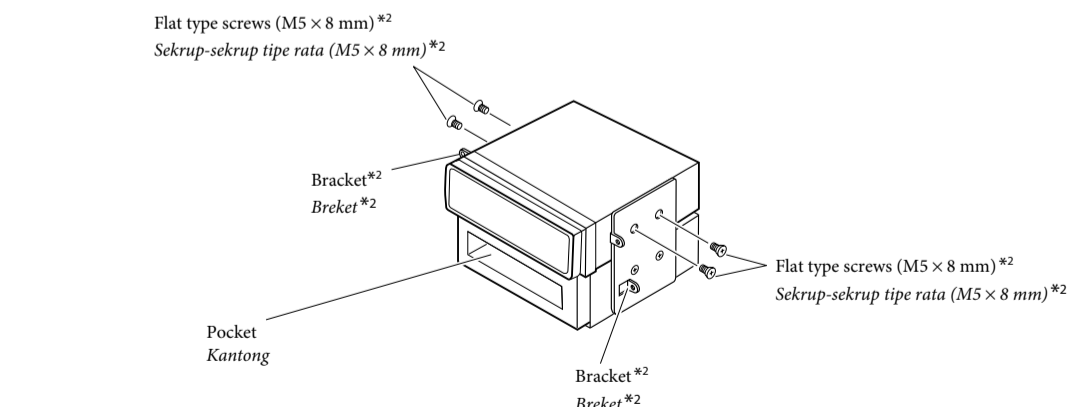

- Note** : When installing the unit on the mounting bracket, make sure to use the 8 mm -long screws. If longer screws are used, they could damage the unit.
- Catatan** : Ketika memasang alat penerima pada breket bingkai, pastikan untuk menggunakan sekrup-sekrup panjang-8 mm. Jika sekrup yang lebih panjang digunakan, maka dapat merusak alat penerima.

*1 When you stand the unit, be careful not to damage the fuse on the rear.
*2 Not supplied for this unit.

*1 Ketika anda memberdirikan alat penerima, hati-hati untuk tidak merusak sekring di belakang.
*2 Tidak disediakan untuk alat penerima ini.

ELECTRICAL CONNECTIONS

SAMBUNGAN-SAMBUNGAN LISTRIK

A Typical connections / Ciri khas sambungan-sambungan

Before connecting: Check the wiring in the vehicle carefully. Incorrect connection may cause serious damage to this unit.
The leads of the power cord and those of the connector from the car body may be different in color.

- 1 Connect the colored leads of the power cord in the order specified in the illustration below.
- 2 Connect the antenna cord.
- 3 Finally connect the wiring harness to the unit.

Sebelum penyambungan: Cek perkabelan dalam mobil dengan hati-hati. Penyambungan yang tidak benar mungkin menyebabkan kerusakan serius pada alat penerima.
Ujung dari kabel power dan beberapa konektor dari bodi mobil mungkin berbeda dalam warna.

- 1 Sambungkan ujung berwarna dari kabel power dalam urutan spesifikasi pada ilustrasi di bawah.
- 2 Sambungkan kabel antenna.
- 3 Akhirnya sambungkan kedudukan kabel ke alat penerima.

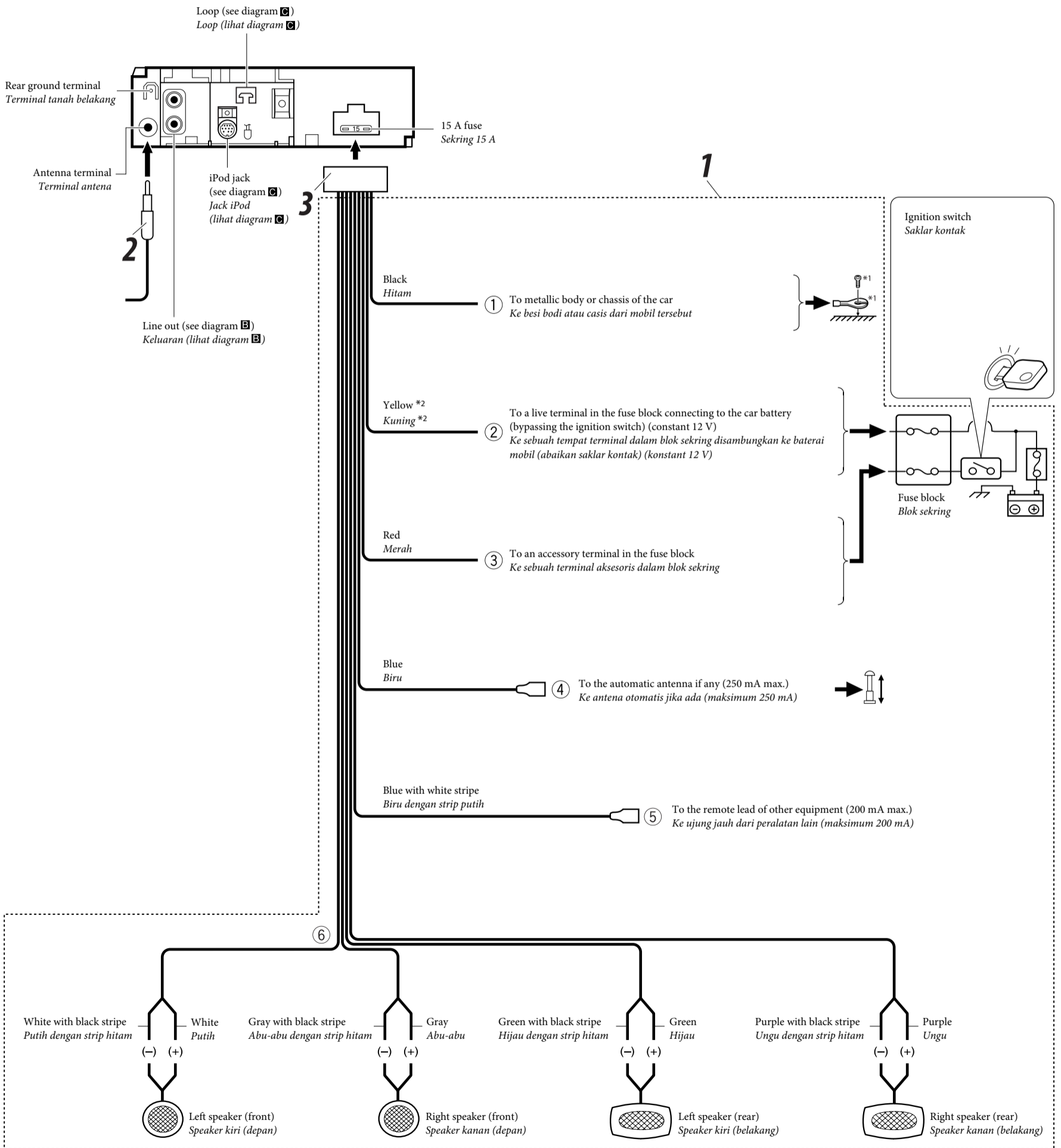

*1 Not supplied for this unit.
*2 Before checking the operation of this unit prior to installation, this lead must be connected, otherwise power cannot be turned on.

*1 Tidak disediakan untuk alat penerima ini.
*2 Sebelum pengecekan pengoperasian dari alat penerima ini sebelum pemasangan, ujung ini harus sudah dihubungkan, selain itu power tidak dapat dihidupkan.

B Connecting the external amplifier or subwoofer / Penyambungan penguat eksternal atau subwoofer

You can connect an amplifier to upgrade your car stereo system.

- Connect the remote lead (blue with white stripe) to the remote lead of the other equipment so that it can be controlled through this unit.
- **Disconnect the speakers from this unit, connect them to the amplifier. Leave the speaker leads of this unit unused.**

Anda dapat menyambungkan penguat untuk meningkatkan sistem stereo mobil anda.

- Sambungkan ujung jauh (biru dengan strip putih) ke ujung jauh dari peralatan lain sehingga dapat dikontrol melalui alat penerima ini.
- **Putuskan sambungan speaker-speaker dari alat penerima ini, sambungkan ini ke penguat. Biarkan ujung speaker dari alat penerima ini tidak digunakan.**

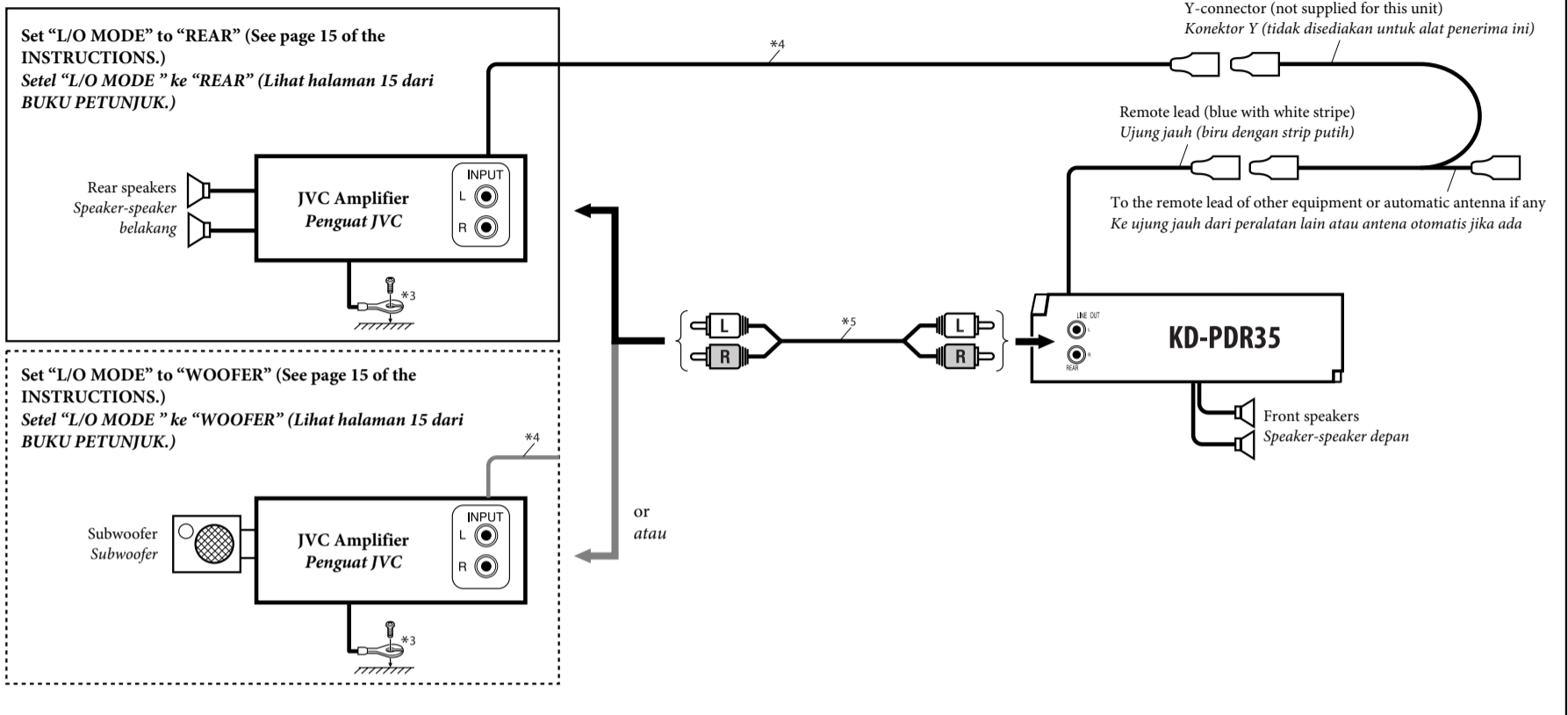

C Connecting an Apple iPod / Menghubungkan Apple iPod

You can connect an iPod to this unit using the supplied connection cable for iPod.

- 1 Insert the supplied cable tie across the loop.
 - 2 Press in the head of the connection cable for iPod until you hear a clicking sound.
 - 3 Fasten the connection cable using the cable tie to firmly hold the connection cable in place.
- Anda dapat menghubungkan iPod dengan menggunakan kabel koneksi iPod yang disediakan.

- 1 Masukkan kabel yang disediakan, ikat melintasi lingkaran.
- 2 Tekan pada bagian kepala kabel sambungan untuk iPod sampai Anda mendengar bunyi klik.
- 3 Kencangkan kabel sambungan dengan menggunakan ikat kabel agar kabel sambungan terpasang di tempatnya.

Apple iPod (separately purchased)
Apple iPod (dibeli terpisah)

Connection cable for iPod (supplied)
Kabel koneksi untuk iPod (disediakan)

iPod is a trademark of Apple Computer, Inc., registered in the U.S. and other countries.
iPod adalah merek dagang dari Apple Computer, Inc., terdaftar di Amerika Serikat dan di negara-negara lain.

- 1
 - 2
 - 3
- Cable tie
Ikat kabel
- KD-PDR35
- Loop
Loop
- *3 Pasangkan dengan kuat kabel tanah ke bodi besi atau ke casing dari mobil—pada tempat yang tidak dilapisi cat (jika dilapisi cat, hilangkan cat sebelum memasang kabel). Kegagalan melakukan ini mungkin menyebabkan kerusakan pada alat penerima tersebut.
- *4 Ujung jauh
- *5 Kabel sinyal (tidak disediakan untuk alat penerima ini)

*3 Firmly attach the ground wire to the metallic body or to the chassis of the car—to the place uncoated with paint (if coated with paint, remove the paint before attaching the wire). Failure to do so may cause damage to the unit.

- *4 Remote lead
*5 Signal cord (not supplied for this unit).

TROUBLESHOOTING

• The fuse blows.

- * Are the red and black leads connected correctly?

• Power cannot be turned on.

- * Is the yellow lead connected?

• No sound from the speakers.

- * Is the speaker output lead short-circuited?

• Sound is distorted.

- * Is the speaker output lead grounded?
- * Are the "-" terminals of L and R speakers grounded in common?

• Noise interfere with sounds.

- * Is the rear ground terminal connected to the car's chassis using shorter and thicker cords?

• This unit becomes hot.

- * Is the speaker output lead grounded?
- * Are the "-" terminals of L and R speakers grounded in common?

• This unit does not work at all.

- * Have you reset your unit?

PEMECAHAN MASALAH

• Sekring meledak.

- * Apakah ujung-ujung merah dan hitam tersambung dengan benar?

• Power tidak dapat dihidupkan.

- * Apakah ujung kuning sudah tersambung?

• Tidak ada suara dari speaker.

- * Apakah ujung keluaran speaker terhubung pendek?

• Suara terdistorsi.

- * Apakah ujung keluaran speaker sudah ditanahkan?
- * Apakah terminal-terminal "-" dari speaker-speaker L dan R sudah ditanahkan secara umum?

• Berisik yang mengganggu suara-suara.

- * Apakah terminal tanah belakang tersambung ke casing mobil menggunakan kabel-kabel terpendek dan tebal?

• Alat penerima menjadi panas.

- * Apakah ujung keluaran speaker sudah ditanahkan?
- * Apakah terminal-terminal "-" dari speaker-speaker L dan R sudah ditanahkan secara umum?

• Alat penerima ini tidak bekerja secara keseluruhan.

- * Apakah anda sudah reset (memasang kembali) alat penerima anda?

JVC



CD RECEIVER

KD-PDR35

ENGLISH

CD 收音組合機

KD-PDR35

中文

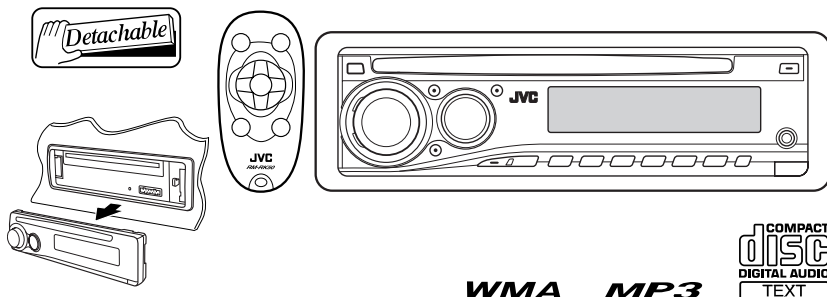

For canceling the display demonstration, see page 6.

取消屏幕演示功能，參閱第 6 頁。

For installation and connections, refer to the separate manual.

有關安裝和連接方法，分別參閱操作手冊。

INSTRUCTIONS 使用說明書

GET0468-005A
[UT]

Thank you for purchasing a JVC product.

Please read all instructions carefully before operation, to ensure your complete understanding and to obtain the best possible performance from the unit.

IMPORTANT FOR LASER PRODUCTS

1. CLASS 1 LASER PRODUCT
2. **CAUTION:** Do not open the top cover. There are no user serviceable parts inside the unit; leave all servicing to qualified service personnel.
3. **CAUTION:** Visible and/or invisible class 1M laser radiation when open. Do not view directly with optical instruments.
4. REPRODUCTION OF LABEL: CAUTION LABEL, PLACED OUTSIDE THE UNIT.

CAUTION VISIBLE AND/OR INVISIBLE CLASS 1M LASER RADIATION WHEN OPEN. DO NOT VIEW DIRECTLY WITH OPTICAL INSTRUMENTS. IEC60825-1:2001 (ENG)	ATTENTION RAYONNEMENT LASER VISIBLE ET/OU INVISIBLE DE CLASSE 1M NE PAS REGARDER DIRECTEMENT AVEC DES INSTRUMENTS OPTIQUES. (FRA)	AVISO RADIACION LASER DE CLASE 1M VISIBLE Y/O INVISIBLE CUANDO ESTA ABIERTO. NO MIRAR DIRECTAMENTE CON INSTRUMENTAL OPTICO. (ESP)	WARNING SYNLIG OCH/ELLER OSYNLIG LASERSTRÅLNING, KLASS 1M, NÅR DENNA DEL ÄR ÖPPNAD. BETRÄKTA EJ STRÅLEN MED OPTISKA INSTRUMENT. (SWE)	注意 ここを覗くと有害 及びまたは不可視 のクラス1M レーザー放射が 出ます。 光学機器で直接 見ないでください。 (JPN)	CAUTION VISIBLE AND/OR INVISIBLE CLASS 1 LASER RADIATION WHEN OPEN. DO NOT STARE INTO BEAM FOR 21 CFR (ENG)
--	---	---	---	---	--



[European Union only]

Warning:

If you need to operate the unit while driving, be sure to look ahead carefully or you may be involved in a traffic accident.

Caution on volume setting:

Discs produce very little noise compared with other sources. Lower the volume before playing a disc to avoid damaging the speakers by the sudden increase of the output level.

How to reset your unit

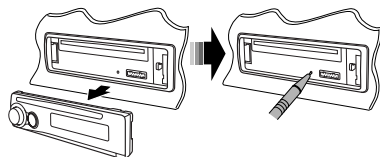

- Your preset adjustments will also be erased.

How to forcibly eject a disc

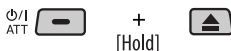

- Be careful not to drop the disc when it ejects.
- If this does not work, reset your unit.

How to use the M MODE button

If you press M MODE, the unit goes into functions mode, then the number buttons and ▲/▼ buttons work as different function buttons.

Ex.: When number button 2 works as MO (monaural) button.



To use these buttons for their original functions again after pressing M MODE, wait for 5 seconds without pressing any of these buttons until the functions mode is cleared or press M MODE again.

Detaching the control panel

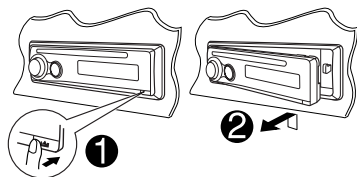

Attaching the control panel

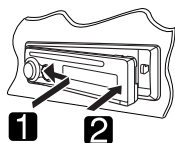

CONTENTS

Control panel	4
Remote controller — RM-RK50.....	5
Getting started.....	6
Basic operations.....	6
Radio operations	7
Disc operations	8
Playing a disc in the unit	8
iPod operations	11
Sound adjustments.....	13
General settings — PSM	14
External component operations	16
Maintenance	16
More about this unit	17
Troubleshooting	21
Specifications	23

For safety...

- Do not raise the volume level too much, as this will block outside sounds, making driving dangerous.
- Stop the car before performing any complicated operations.

Temperature inside the car...

If you have parked the car for a long time in hot or cold weather, wait until the temperature in the car becomes normal before operating the unit.

Control panel

Parts identification

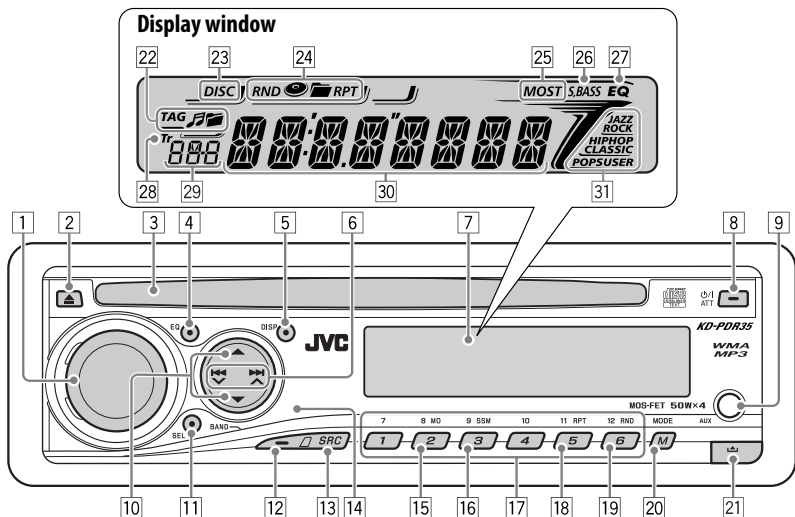

- | | |
|--|--|
| 1 Control dial | 19 RND (random) button |
| 2 ▲ (eject) button | 20 M MODE button |
| 3 Loading slot | 21 ▲ (control panel release) button |
| 4 EQ (equalizer) button | 22 Disc information indicators—
TAG (Tag information), 🎵 (track/file), 📁 (folder) |
| 5 DISP (display) button | 23 DISC indicator |
| 6 ⏮ ⏪ ⏩ ⏭ buttons | 24 Playback mode / item indicators— RND (random),
👁️ (disc), 📁 (folder), RPT (repeat) |
| 7 Display window | 25 Tuner reception indicators—MO (monaural),
ST (stereo) |
| 8 ⏻ / ATT (standby/on attenuator) button | 26 S.BASS (super bass) indicator |
| 9 AUX (auxiliary) input jack | 27 EQ (equalizer) indicator |
| 10 ▲ (up) / ▼ (down) buttons | 28 Tr (track) indicator |
| 11 SEL (select) button | 29 Source display / Time countdown indicator |
| 12 BAND button | 30 Main display |
| 13 SRC (source) button | 31 Sound mode (iEQ: intelligent equalizer)
indicators—JAZZ, ROCK, HIP HOP, CLASSIC, POPS,
USER |
| 14 Remote sensor
<i>DO NOT expose the remote sensor to strong light
(direct sunlight or artificial lighting).</i> | |
| 15 MO (monaural) button | |
| 16 SSM (Strong-station Sequential Memory) button | |
| 17 Number buttons | |
| 18 RPT (repeat) button | |

Installing the lithium coin battery (CR2025)

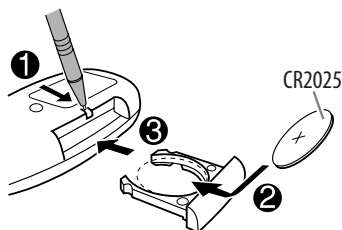

Aim the remote controller directly at the remote sensor on the unit. Make sure there is no obstacle in between.

Warning:

- Do not install any battery other than CR2025 or its equivalent; otherwise, it may explode.
- Do not leave the remote controller in a place (such as dashboards) exposed to direct sunlight for a long time; otherwise, it may explode.
- Store the battery in a place where children cannot reach to avoid risk of accident.
- To prevent the battery from over-heating, cracking, or starting a fire:
 - Do not recharge, short, disassemble, heat the battery, or dispose of it in a fire.
 - Do not leave the battery with other metallic materials.
 - Do not poke the battery with tweezers or similar tools.
 - Wrap the battery with tape and insulate when throwing away or saving it.

Main elements and features

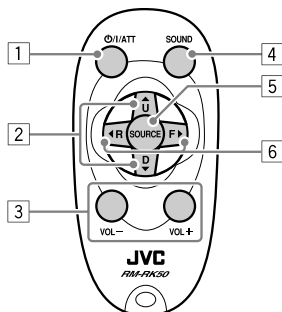

- 1 ϕ /I/ATT (standby/on/attenuator) button
 - Turns the power on if pressed briefly or attenuates the sound when the power is on.
 - Turns the power off if pressed and held.
- 2 \blacktriangle U (up) / D (down) \blacktriangledown buttons
 - Changes the FM/AM bands with \blacktriangle U.
 - Changes the preset stations with D \blacktriangledown .
 - Changes the folder of the MP3/WMA discs.
 - While listening to an Apple iPod.
 - Pauses or resumes playback with D \blacktriangledown .
 - Enters the main menu with \blacktriangle U.
 (Now \blacktriangle U/D \blacktriangledown / \blacktriangleleft R/F \blacktriangleright work as the menu selecting buttons.)*
- 3 VOL – / VOL + buttons
 - Adjusts the volume level.
- 4 SOUND button
 - Selects the sound mode (iEQ: intelligent equalizer).
- 5 SOURCE button
 - Selects the source.

* \blacktriangle U : Returns to the previous menu.
 D \blacktriangledown : Confirms the selection.

- 6 ◀ R (reverse) / F (forward) ▶ buttons
- Searches for stations if pressed briefly.
 - Fast-forwards or reverses the track if pressed and held.
 - Changes the tracks if pressed briefly.
 - While listening to an iPod (in menu selecting mode):
 - Selects an item if pressed briefly. (Then, press D ▼ to confirm the selection.)
 - Skips 10 items at a time if pressed and held.

Getting started

Basic operations

1 Turn on the power.



2

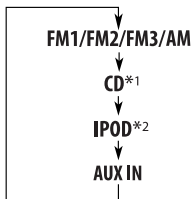

*1 You cannot select "CD" as the playback source if there is no disc in the unit.

*2 "NO IPOD" appears if iPod is not connected.

3 For FM/AM tuner



4 Adjust the volume.

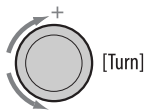

Volume level appears.

5 Adjust the sound as you want. (See page 13.)

To drop the volume in a moment (ATT) To restore the sound, press the button again.	
To turn off the power	[Hold]

Basic settings

- See also "General settings — PSM" on pages 14 and 15.

1



2

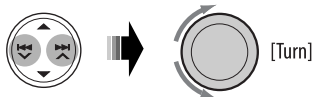

1 Canceling the display demonstrations

Select "DEMO," then "DEMO OFF."

2 Setting the clock

Select "CLOCK H" (hour), then adjust the hour.
 Select "CLOCK M" (minute), then adjust the minute.

3 Finish the procedure.



To check the current clock time while the power is turned off



Clock time is shown on the display for about 5 seconds. See also page 14.

Radio operations



Lights up when receiving an FM stereo broadcast with sufficient signal strength.



3 Start searching for a station.



When a station is received, searching stops.
To stop searching, press the same button again.

To tune in to a station manually

In step 3 above...



2 Select a desired station frequency.



When an FM stereo broadcast is hard to receive



Lights up when monaural mode is activated.



Reception improves, but stereo effect will be lost.

To restore the stereo effect, repeat the same procedure. "MONO OFF" appears and the MO indicator goes off.

Storing stations in memory

You can preset six stations for each band.

■ FM station automatic presetting—SSM (Strong-station Sequential Memory)

1 Select the FM band (FM1 – FM3) you want to store into.

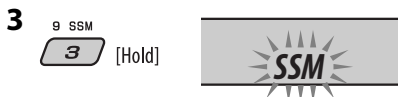



"SSM" flashes, then disappears when automatic presetting is over.

Local FM stations with the strongest signals are searched and stored automatically in the FM band.

Manual presetting

Ex.: Storing FM station of 92.5 MHz into preset number 4 of the FM1 band.

- 
- 
- 

Preset number flashes for a while.

Listening to a preset station

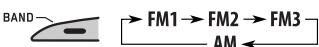
- 
- Select the preset station (1 – 6) you want.



or



To check other information while listening to the radio



Clock ↔ Frequency

Disc operations

Playing a disc in the unit

All tracks will be played repeatedly until you change the source or eject the disc.

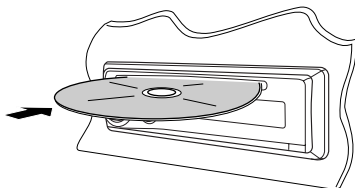

To stop play and eject the disc



- Press SRC to listen to another playback source.

To fast-forward or reverse the track



To go to the next or previous tracks



To go to the next or previous folders (only for MP3 or WMA discs)



To locate a particular track (for CD) or folder (for MP3 or WMA discs) directly

To select a number from 01 – 06:



To select a number from 07 – 12:



[Hold]

- To use direct folder access on MP3/WMA discs, it is required that folders are assigned with 2-digit numbers at the beginning of their folder names—01, 02, 03, and so on.

To select a particular track in a folder (for MP3 or WMA discs):



Other main functions

■ Skipping tracks quickly during play

- For MP3 or WMA discs, you can skip tracks within the same folder.

Ex.: To select track 32 while playing a track whose number is a single digit (1 to 9)

1 MODE

2 Track 1 to 9 → Track 10
..... 30 ← 20 ←

Each time you press the button, you can skip 10 tracks.

- After the last track, the first track will be selected and vice versa.

3 Track 31 → 32 →

■ Prohibiting disc ejection

You can lock a disc in the loading slot.

+ [Hold]



To cancel the prohibition, repeat the same procedure.

Changing the display information



While playing an audio CD or a CD Text

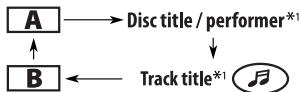

While playing an MP3 or a WMA track

- When "TAG DISP" is set to "TAG ON" (see page 15)

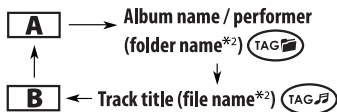

- When "TAG DISP" is set to "TAG OFF"

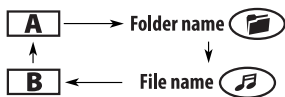

- : Clock with the current track number
 : Elapsed playing time with the current track number
 : Corresponding indicator lights up on the display

*¹ If the current disc is an audio CD, "NO NAME" appears.

*² If an MP3/WMA file does not have Tag information, folder name and file name appear. In this case, the TAG indicator will not light up.

Selecting the playback modes

You can use only one of the following playback modes at a time.

1 MODE



2 Select your desired playback mode.

Repeat play

11 RPT



Mode	Plays repeatedly
TRK RPT	: The current track.
FLDR RPT*	: All tracks of the current folder.
RPT OFF	: Cancels.



Random play

12 RND



Mode	Plays at random
FLDR RND*	: All tracks of the current folder, then tracks of the next folder and so on.
DISC RND	: All tracks of the current disc.
RND OFF	: Cancels.



* Only while playing an MP3 or a WMA disc.

: Corresponding indicator lights up on the display

iPod operations

You can play songs from an Apple iPod through this unit by connecting it with the supplied connection cable for iPod.

- Disconnecting the iPod will stop playback. Press SRC to listen to another playback source.
- For connection, see Installation/Connection Manual (separate volume).
- For details, refer also to the manual supplied with your iPod.

1 Connect an iPod.

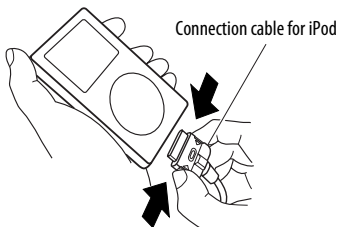

If an iPod has been connected...



Playback starts automatically from where it has been paused previously.

2 Adjust the volume.

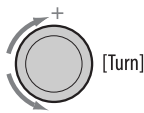

3 Adjust the sound as you want. (See page 13.)

Caution:

- Avoid using the iPod if it might hinder your safety driving.
- Make sure all important data has been backed up to avoid losing the data.

To pause playback



To resume playback, press the button again.

To fast-forward or reverse the track



To go to the next or previous tracks



Selecting a track from the menu

1 Enter the main menu.



Now the ▲/▼/◀◀/▶▶/▶▶|▲ buttons work as the menu selecting buttons*.

2 Select the desired menu.



PLAYLIST ↔ ARTISTS ↔ ALBUMS ↔
SONGS ↔ GENRES ↔ COMPOSER ↔
(back to the beginning)

3 Confirm the selection.



To move back to the previous menu, press ▲.

- If a track is selected, playback starts automatically.
- If the selected item has another layer, you will enter the layer. Repeat steps **2** and **3** until the desired track is played (see page 20).
- Holding ◀◀/▶▶/▶▶|▲ can skip 10 items at a time.

- * The menu selecting mode will be canceled:
- If no operations are done for about 5 seconds.
 - When you confirm the selection of a track.

Selecting the playback modes

1 MODE



2 Select your desired playback mode.



■ Repeat play

11 RPT



Mode Playback functions (as on iPod)

ONE RPT : Same as "Repeat One." 

ALL RPT : Same as "Repeat All."  

RPT OFF : Cancels.

■ Random play

12 RND



Mode Playback functions (as on iPod)

ALBM RND*: Same as "Shuffle Albums."



SONG RND : Same as "Shuffle Songs." 

RND OFF : Cancels.

* Functions only if you select "ALL" in "ALBUMS" of the main "MENU."

 : Corresponding indicator lights up on the display

To check other information while listening to an iPod



Sound adjustments

You can select a preset sound mode suitable to the music genre (iEQ: intelligent equalizer).



Preset values	Indication (For)			
	BAS* ¹	MID* ²	TRE* ³	S.BS* ⁴
USER (Flat sound)	00	00	00	OFF
ROCK (Rock or disco music)	+03	00	+02	ON
CLASSIC (Classical music)	+01	00	+03	OFF
POPS (Light music)	+02	+01	+02	OFF
HIP HOP (Funk or rap music)	+04	-02	+01	ON
JAZZ (Jazz music)	+03	00	+03	OFF

*1 : Bass; *2 : Mid-range; *3 : Treble; *4 : Super bass

Adjusting the sound

You can adjust the sound characteristics to your preference.

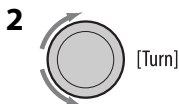
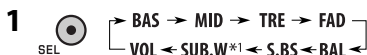

Indication, [Range]

BAS*² (bass), [-06 to +06]

Adjust the bass.

MID*² (mid-range), [-06 to +06]

Adjust the mid-range frequencies sound level.

TRE*² (treble), [-06 to +06]

Adjust the treble.

FAD*³ (fader), [R06 to F06]

Adjust the front and rear speaker balance.

BAL*⁴ (balance), [L06 to R06]

Adjust the left and right speaker balance.

S.BS*² (super bass), [S.BS ON or S.BS OFF], [01 to 05, initial: 03]*⁵

Maintain the richness and fullness of the bass sound regardless of how low you set the volume.

SUB.W*¹ (subwoofer), [00 to 08, initial: 04]

Adjust the subwoofer output level.

VOL (volume), [00 to 30 or 50*⁶]

Adjust the volume.

*1 Displayed only when "L/O MODE" is set to "WOOFER" (see page 15).

*2 When you adjust the bass, mid-range, treble, or super bass, the adjustment you have made is stored for the currently selected sound mode (iEQ) including "USER."

*3 If you are using a two-speaker system, set the fader level to "00."

*4 This adjustment will not affect the subwoofer output.

*5 Range adjustment for super bass is adjustable only when it is set to "S.BS ON."

*6 Depending on the amplifier gain control setting. (See page 15 for details.)

General settings — PSM

You can change PSM (Preferred Setting Mode) items listed in the table that follows.

1  [Hold]

2 Select a PSM item.



3 Adjust the PSM item selected.

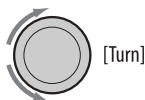

4 Repeat steps 2 and 3 to adjust other PSM items if necessary.

5 Finish the procedure.



Indications	Item (__: Initial)	Setting, [reference page]
DEMO Display demonstration	<ul style="list-style-type: none"> • DEMO ON • DEMO OFF 	<ul style="list-style-type: none"> : Display demonstration will be activated automatically if no operation is done for about 20 seconds, [6]. : Cancels.
CLK DISP *1 Clock display	<ul style="list-style-type: none"> • ON • OFF 	<ul style="list-style-type: none"> : Clock time is shown on the display at all times when the power is turned off. : Cancels; pressing DISP will show the clock time for about 5 seconds when the power is turned off, [6].
CLOCK H Hour adjustment	1 – 12	[Initial: 1 (1:00)], [6].
CLOCK M Minute adjustment	00 – 59	[Initial: 00 (1:00)], [6].
DIMMER Dimmer	<ul style="list-style-type: none"> • ON • OFF 	<ul style="list-style-type: none"> : Dims the display illumination. : Cancels.

*1 If the power supply is not interrupted by turning off the ignition key of your car, it is recommended to select "OFF" to save the car's battery.

Indications	Item (__: Initial)	Setting, [reference page]
SCROLL * ₂ Scroll	<ul style="list-style-type: none"> • ONCE • AUTO • OFF 	<ul style="list-style-type: none"> : Scrolls the track information once. : Repeats scrolling (at 5-second intervals). : Cancels. • Pressing DISP for more than one second can scroll the display regardless of the setting.
L/O MODE Line output mode	<ul style="list-style-type: none"> • REAR • WOOFER 	<ul style="list-style-type: none"> : Select if the REAR LINE OUT terminals are used for connecting the speakers (through an external amplifier). : Select if the REAR LINE OUT terminals are used for connecting a subwoofer (through an external amplifier).
WOOFER * ₃ Subwoofer cutoff frequency	<ul style="list-style-type: none"> • LOW • MID • HIGH 	<ul style="list-style-type: none"> : Frequencies lower than 90 Hz are sent to the subwoofer. : Frequencies lower than 135 Hz are sent to the subwoofer. : Frequencies lower than 180 Hz are sent to the subwoofer.
AUX ADJ Auxiliary input level adjustment	A.ADJ 00 — A.ADJ 05	: Adjust the auxiliary input level to avoid the sudden increase of the output level when changing the source from external component connected to the AUX input jack on the control panel.
TAG DISP Tag display	<ul style="list-style-type: none"> • TAG ON • TAG OFF 	<ul style="list-style-type: none"> : Shows the Tag information while playing MP3/WMA tracks, [10]. : Cancels.
AMP GAIN Amplifier gain control	<ul style="list-style-type: none"> • LOW PWR • HIGH PWR 	<ul style="list-style-type: none"> : VOL 00 – VOL 30. (Select this if the maximum power of the speaker is less than 50 W to prevent damaging the speaker.) : VOL 00 – VOL 50.
IF BAND Intermediate frequency band	<ul style="list-style-type: none"> • AUTO • WIDE 	<ul style="list-style-type: none"> : Increases the tuner selectivity to reduce interference noises between close stations. (Stereo effect may be lost.) : Subject to interference noises from adjacent stations, but sound quality will not be degraded and the stereo effect will remain.

*₂ Some characters or symbols will not be shown correctly (or will be blanked) on the display.

*₃ Displayed only when "L/O MODE" is set to "WOOFER."

External component operations

You can connect an external component to the AUX (auxiliary) input jack on the control panel.

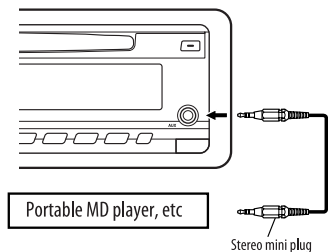

- 1  → AUX IN →
- 2 Turn on the connected component and start playing the source.
- 3 Adjust the volume.

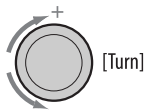

- 4 Adjust the sound as you want. (See page 13.)

To check other information while listening to an external component



Clock ↔ AUX IN

Maintenance

How to clean the connectors

Frequent detachment will deteriorate the connectors. To minimize this possibility, periodically wipe the connectors with a cotton swab or cloth moistened with alcohol, being careful not to damage the connectors.

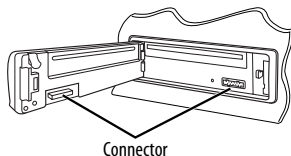

Moisture condensation

Moisture may condense on the lens inside the unit in the following cases:

- After starting the heater in the car.
- If it becomes very humid inside the car.

Should this occur, the unit may malfunction. In this case, eject the disc and leave the unit turned on for a few hours until the moisture evaporates.

How to handle discs

When removing a disc from its case, press down the center holder of the case and lift the disc out, holding it by the edges.



- Always hold the disc by the edges. Do not touch its recording surface.

When storing a disc into its case, gently insert the disc around the center holder (with the printed surface facing up).

- Make sure to store discs into the cases after use.

To keep discs clean

A dirty disc may not play correctly. If a disc does become dirty, wipe it with a soft cloth in a straight line from center to edge.



- Do not use any solvent (for example, conventional record cleaner, spray, thinner, benzene, etc.) to clean discs.

To play new discs

New discs may have some rough spots around the inner and outer edges. If such a disc is used, this unit may reject the disc.



To remove these rough spots, rub the edges with a pencil or ball-point pen, etc.

Do not use the following discs:

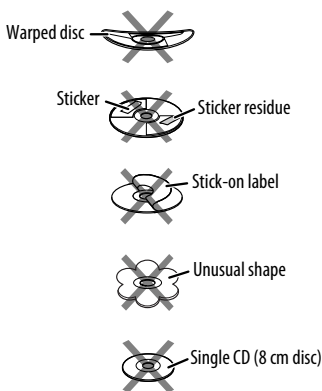

More about this unit

Basic operations

Turning on the power

- By pressing SRC on the unit, you can also turn on the power. If the source is ready, playback also starts.

Turning off the power

- If you turn off the power while listening to a track, playback starts from where playback it has been stopped previously, next time you turn on the power.

General

- If you change the source while listening to a disc or an iPod, playback stops. Next time you select "CD" or "IPOD" as the playback source, playback starts from where it has been stopped/paused previously.
- After ejecting a disc or disconnecting an iPod, "NO DISC" or "NO IPOD" appears and you cannot operate some of the buttons. Insert another disc, reconnect an iPod, or press SRC to select another playback source.

Tuner operations

Storing stations in memory

- During SSM search...
 - All previously stored stations are erased and stations are stored newly.
 - Received stations are preset in No. 1 (lowest frequency) to No. 6 (highest frequency).
 - When SSM is over, the station stored in No. 1 will be automatically tuned in.
- When storing a station manually, the previously preset station is erased when a new station is stored in the same preset number.

Continued on the next page

Disc operations

Caution for DualDisc playback

- The Non-DVD side of a “DualDisc” does not comply with the “Compact Disc Digital Audio” standard. Therefore, the use of Non-DVD side of a DualDisc on this product may not be recommended.

General

- This unit has been designed to reproduce CDs/CD Texts, and CD-Rs (Recordable)/CD-RWs (Rewritable) in audio CD (CD-DA), MP3 and WMA formats.
- When a disc is inserted upside down, “PLEASE” and “EJECT” appear alternately on the display. Press ▲ to eject the disc.
- MP3 and WMA “tracks” (words “file” and “track” are used interchangeably) are recorded in “folders.”
- While fast-forwarding or reversing on an MP3 or WMA disc, you can only hear intermittent sounds.

Playing a CD-R or CD-RW

- Use only “finalized” CD-Rs or CD-RWs.
- This unit can play back only files of the same type which are first detected if a disc includes both audio CD (CD-DA) files and MP3/WMA files.
- This unit can play back multi-session discs; however, unclosed sessions will be skipped while playing.
- Some CD-Rs or CD-RWs may not play back on this unit because of their disc characteristics, or for the following reasons:
 - Discs are dirty or scratched.
 - Moisture condensation occurs on the lens inside the unit.
 - The pickup lens inside the unit is dirty.
 - CD-R/CD-RW on which the files are written with “Packet Write” method.
 - There are improper recording conditions (missing data, etc.) or media conditions (stained, scratched, warped, etc.).
- CD-RWs may require a longer readout time since the reflectance of CD-RWs is lower than that of regular CDs.

- Do not use the following CD-Rs or CD-RWs:
 - Discs with stickers, labels, or a protective seal stuck to the surface.
 - Discs on which labels can be directly printed by an ink jet printer.
 Using these discs under high temperatures or high humidities may cause malfunctions or damage to the unit.

Playing an MP3/WMA disc

- This unit can play back MP3/WMA files with the extension code <.mp3> or <.wma> (regardless of the letter case—upper/lower).
- This unit can show the names of albums, artists (performer), and Tag (Version 1.0, 1.1, 2.2, 2.3, or 2.4) for MP3 files and for WMA files.
- This unit can display only one-byte characters. No other characters can be correctly displayed.
- This unit can play back MP3/WMA files meeting the conditions below:
 - Bit rate: 8 kbps — 320 kbps
 - Sampling frequency:
 - 48 kHz, 44.1 kHz, 32 kHz (for MPEG-1)
 - 24 kHz, 22.05 kHz, 16 kHz (for MPEG-2)
 - Disc format: ISO 9660 Level 1/Level 2, Romeo, Joliet, Windows long file name
- The maximum number of characters for file/folder names vary among the disc format used (includes 4 extension characters—<.mp3> or <.wma>).
 - ISO 9660 Level 1: up to 12 characters
 - ISO 9660 Level 2: up to 31 characters
 - Romeo: up to 128 characters
 - Joliet: up to 64 characters
 - Windows long file name: up to 128 characters
- This unit can recognize a total of 512 files, of 200 folders, and of 8 hierarchies.
- This unit can play back files recorded in VBR (variable bit rate).
Files recorded in VBR have a discrepancy in elapsed time display, and do not show the actual elapsed time. Especially, after performing the search function, this difference becomes noticeable.

- This unit cannot play back the following files:
 - MP3 files encoded with MP3i and MP3 PRO format.
 - MP3 files encoded in an inappropriate format.
 - MP3 files encoded with Layer 1/2.
 - WMA files encoded with lossless, professional, and voice format.
 - WMA files which are not based upon Windows Media® Audio.
 - WMA files copy-protected with DRM.
 - Files which have the data such as AIFF, ATRAC3, etc.
- The search function works but search speed is not constant.
- When you turn on this unit, the iPod is charged through this unit.
- While the iPod is connected, all operations from the iPod are disabled. Perform all operations from this unit.
- While connecting an iPod with Video:
 - No video shows on the iPod's display or the external monitor (only the audio part is available).
 - It is not possible to browse video files on the "Video" menu. (If you connect the iPod during playback or pausing of a video file, resuming playback will not work.)

Ejecting a disc

- If the ejected disc is not removed within 15 seconds, the disc is automatically inserted again into the loading slot to protect it from dust. Playback starts automatically.

iPod operations

Controllable iPod	Software version
iPod with dock connector (3rd Generation)	2.3 or later
iPod with Click Wheel (4th Generation)	3.1 or later
iPod mini	1.4 or later
iPod photo	1.2 or later
iPod nano	1.0 or later
iPod with Video (5th Generation)	1.0 or later

- If your iPod software version is older than those mentioned above, you may not be able to control the iPod properly. Update your iPod to the latest software version before using it with this unit.
 - You can check the software version of your iPod from "About" in the "Setting" menu of the iPod.
 - For details about updating your iPod, visit <<http://www.apple.com>>.

- When you turn on this unit, the iPod is charged through this unit.
- While the iPod is connected, all operations from the iPod are disabled. Perform all operations from this unit.
- While connecting an iPod with Video:
 - No video shows on the iPod's display or the external monitor (only the audio part is available).
 - It is not possible to browse video files on the "Video" menu. (If you connect the iPod during playback or pausing of a video file, resuming playback will not work.)
- iPod shuffle is not controllable.
- You can control the iPod from this unit when "JVC" or "✓" appears on the iPod display.
- The songs order displayed on the selecting menu of this unit may differ from the iPod.
- If playback is stopped, select a track from the selecting menu or press ▼.
- The text information may not be displayed correctly.
 - Some characters such as accented letters cannot be shown correctly on the display.
 - Depends on the condition of communication between the iPod and the unit.
- If the text information includes more than 8 characters, it scrolls on the display. This unit can display up to 40 characters.

General settings—PSM

- If you change the "AMP GAIN" setting from "HIGH PWR" to "LOW PWR" while the volume level is set higher than "VOL 30," the unit automatically changes the volume level to "VOL 30."

Hierarchical structure of file searching when an iPod is connected

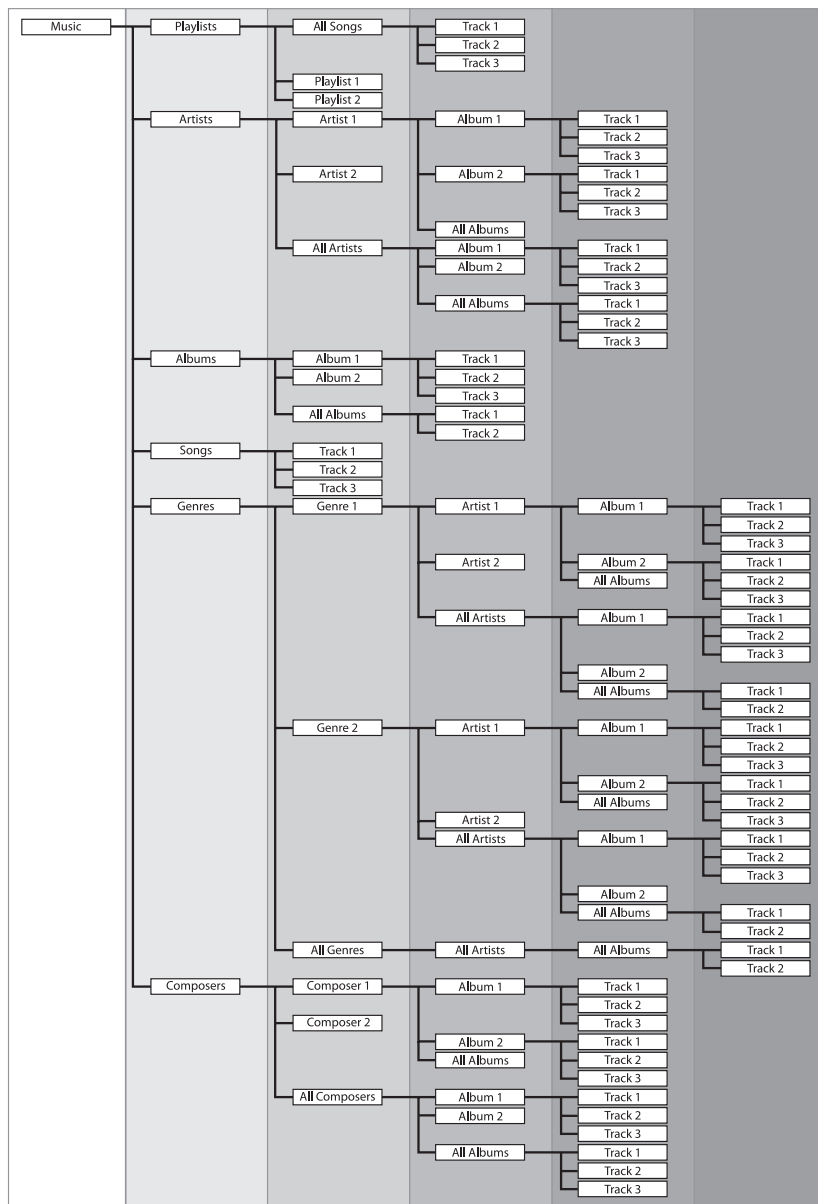

Troubleshooting

What appears to be trouble is not always serious. Check the following points before calling a service center.

	Symptoms	Remedies/Causes
General	<ul style="list-style-type: none"> Sound cannot be heard from the speakers. 	<ul style="list-style-type: none"> Adjust the volume to the optimum level. Check the cords and connections.
	<ul style="list-style-type: none"> The unit does not work at all. 	Reset the unit (see page 2).
FM/AM	<ul style="list-style-type: none"> SSM automatic presetting does not work. 	Store stations manually.
	<ul style="list-style-type: none"> Static noise while listening to the radio. 	Connect the antenna firmly.
Disc playback	<ul style="list-style-type: none"> Disc cannot be played back. 	Insert the disc correctly.
	<ul style="list-style-type: none"> CD-R/CD-RW cannot be played back. Tracks on the CD-R/CD-RW cannot be skipped. 	<ul style="list-style-type: none"> Insert a finalized CD-R/CD-RW. Finalize the CD-R/CD-RW with the component which you used for recording.
	<ul style="list-style-type: none"> Disc can neither be played back nor ejected. 	<ul style="list-style-type: none"> Unlock the disc (see page 9). Eject the disc forcibly (see page 2).
	<ul style="list-style-type: none"> Disc sound is sometimes interrupted. 	<ul style="list-style-type: none"> Stop playback while driving on rough roads. Change the disc. Check the cords and connections.
	<ul style="list-style-type: none"> "NO DISC" appears on the display. 	Insert a playable disc into the loading slot.
MP3/WMA playback	<ul style="list-style-type: none"> Disc cannot be played back. 	<ul style="list-style-type: none"> Use a disc with MP3/WMA tracks recorded in the format compliant with ISO 9660 Level 1, Level 2, Romeo, or Joliet. Add the extension code <.mp3> or <.wma> to the file names.
	<ul style="list-style-type: none"> Noise is generated. 	Skip to another track or change the disc. (Do not add the extension code <.mp3> or <.wma> to non-MP3 or WMA tracks.)
	<ul style="list-style-type: none"> A longer readout time is required ("CHECK" keeps flashing on the display). 	Do not use too many hierarchies and folders.

Continued on the next page

	Symptoms	Remedies/Causes
MP3/WMA playback	• Tracks do not play back in the order you have intended them to play.	Playback order is determined when the files are recorded.
	• Elapsed playing time is not correct.	This sometimes occurs during play. This is caused by how the tracks are recorded on the disc.
	• "PLEASE" and "EJECT" appear alternately on the display.	Insert a disc that contains MP3/WMA tracks.
	• Correct characters are not displayed (e.g. album name).	This unit can only display letters (upper case), numbers, and a limited number of symbols.
iPod playback	• The iPod does not turn on or does not work.	<ul style="list-style-type: none"> • Check the connecting cable and its connection. • Update the firmware version. • Charge the battery.
	• The sound is distorted.	Deactivate the equalizer either on the unit or the iPod.
	• "NO IPOD" appears on the display.	<ul style="list-style-type: none"> • Check the connecting cable and its connection. • Charge the battery
	• Playback stops.	The headphones are disconnected during playback. Turn off the unit's power and turn it on again.
	• No sound can be heard when connecting an iPod nano.	<ul style="list-style-type: none"> • Disconnect the headphones from the iPod nano. • Update the firmware version of the iPod nano.
	• "NO FILES" appears on the display.	No tracks are stored. Import tracks to the iPod.
	• "RESET 1" – "RESET 7" appears on the display.	Reconnect the iPod.
	• "RESET 8" appears on the display.	Check the connecting cable and its connection
• The iPod's controls do not work after disconnecting from this unit.	Reset the iPod.	

- Microsoft and Windows Media are either registered trademarks or trademarks of Microsoft Corporation in the United States and/or other countries.
- iPod is a trademark of Apple Computer, Inc., registered in the U.S. and other countries.

Specifications

AUDIO AMPLIFIER SECTION

Maximum Power Output:	
Front/Rear:	50 W per channel
Continuous Power Output (RMS):	
Front/Rear:	19 W per channel into 4 Ω , 40 Hz to 20 000 Hz at no more than 0.8% total harmonic distortion.
Load Impedance:	4 Ω (4 Ω to 8 Ω allowance)
Tone Control Range:	
Bass:	± 12 dB at 60 Hz
Mid-range:	± 12 dB at 1 kHz
Treble:	± 12 dB at 7.5 kHz
Frequency Response:	40 Hz to 20 000 Hz
Signal-to-Noise Ratio:	70 dB
Line-Out Level/Impedance:	2.5 V/20 k Ω load (full scale)
Subwoofer-Out Level/Impedance:	2.5 V /20 k Ω load (full scale)
Output Impedance:	1 k Ω
Other Terminal:	AUX (auxiliary) input jack, iPod jack

TUNER SECTION

Frequency Range:	
FM:	87.5 MHz to 108.0 MHz
AM:	531 kHz to 1 602 kHz
FM Tuner	
Usable Sensitivity:	11.3 dBf (1.0 μ V/75 Ω)
50 dB Quieting Sensitivity:	16.3 dBf (1.8 μ V/75 Ω)
Alternate Channel Selectivity (400 kHz):	65 dB
Frequency Response:	40 Hz to 15 000 Hz
Stereo Separation:	30 dB
AM Tuner	
Sensitivity:	20 μ V
Selectivity:	35 dB

CD PLAYER SECTION

Type:	Compact disc player
Signal Detection System:	Non-contact optical pickup (semiconductor laser)
Number of Channels:	2 channels (stereo)
Frequency Response:	5 Hz to 20 000 Hz
Dynamic Range:	96 dB
Signal-to-Noise Ratio	98 dB
Wow and Flutter:	Less than measurable limit
MP3 Decoding Format: (MPEG1/2 Audio Layer 3)	
Max. Bit Rate:	320 kbps
WMA (Windows Media [®] Audio) Decoding Format:	
Max. Bit Rate:	192 kbps

GENERAL

Power Requirement:	
Operating Voltage:	DC 14.4 V (11 V to 16 V allowance)
Grounding System:	Negative ground
Allowable Operating Temperature:	0°C to +40°C
Dimensions (W \times H \times D): (approx.)	
Installation Size:	182 mm \times 52 mm \times 150 mm
Panel Size:	187 mm \times 58 mm \times 13 mm
Mass:	1.3 kg (excluding accessories)

Design and specifications are subject to change without notice.

Having TROUBLE with operation?

Please reset your unit

Refer to page of How to reset your unit

在操作時遇到麻煩了？

請重設本機

參閱如何重設本機之頁

JVC



EN, CT

© 2006 Victor Company of Japan, Limited

1206DTSMDTJEIN

JVC KD-PDR35

Installation/Connection Manual

安裝/連接手冊

GET0468-010A
[UT]

1206DTSMDTJEIN
EN, CT

© 2006 Victor Company of Japan, Limited

ENGLISH

This unit is designed to operate on **12 V DC, NEGATIVE ground electrical systems**. If your vehicle does not have this system, a voltage inverter is required, which can be purchased at JVC car audio dealers.

WARNINGS

To prevent short circuits, we recommend that you disconnect the battery's negative terminal and make all electrical connections before installing the unit.

- **Be sure to ground this unit to the car's chassis again after installation.**

Notes:

- Replace the fuse with one of the specified rating. If the fuse blows frequently, consult your JVC car audio dealer.
- It is recommended to connect to the speakers with maximum power of more than 50 W (both at the rear and at the front, with an impedance of **4 Ω to 8 Ω**). If the maximum power is less than 50 W, change "AMP GAIN" setting to prevent the speakers from being damaged (see page 15 of the INSTRUCTIONS).
- To prevent short-circuit, cover the terminals of the UNUSED leads with insulating tape.
- The heat sink becomes very hot after use. Be careful not to touch it when removing this unit.

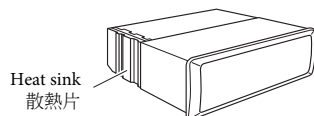

中文

本機僅可使用直流 **12 V**、負極接地的電源系統。如果您的車輛沒有這一電源系統，則需要一個電壓變換器，可以在 JVC 汽車音響分銷商處買到。

警告

為防止短路，建議在安裝本機之前，斷開電池的負極，並把所有電路都連接好。

- 安裝完畢後務必將本機的地線重新接至車身。

注意：

- 把保險絲更換為額定負荷值的保險絲。如果保險絲經常燒壞，請向 JVC 汽車音響分銷商詢問。
- 後置和前置揚聲器的最大輸入功率應大於 50 W，其阻抗為 **4 Ω - 8 Ω**。如果最大功率小於 50 W，請調校 "AMP GAIN" 設定值，以防止揚聲器損壞。（參閱使用說明書的第 15 頁。）
- 為防止電源短路，請用絕緣帶包住未使用電線的端子。
- 本機使用後，散熱片會很熱。因此，在移出本機時，小心不要觸摸散熱片。

PRECAUTIONS on power supply and speaker connections:

- **DO NOT connect the speaker leads of the power cord to the car battery; otherwise, the unit will be seriously damaged.**
- BEFORE connecting the speaker leads of the power cord to the speakers, check the speaker wiring in your car.

電源和揚聲器接線注意事項：

- 切勿把揚聲器導線接頭接至電池，否則本機將會嚴重損壞。
- 在把揚聲器導線接頭接至揚聲器之前，檢查您汽車上的揚聲器線路。

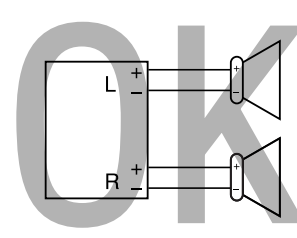
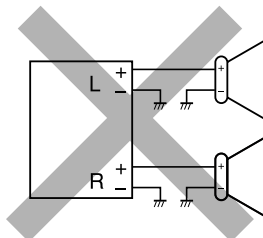
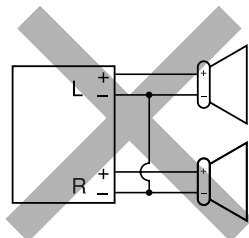

Parts list for installation and connection

The following parts are provided for this unit. If any item is missing, consult your JVC car audio dealer immediately.

用於安裝和連接的零件清單

下列零件隨本機提供。若有任何遺漏，立刻咨詢您的 JVC 汽車音響經銷商。

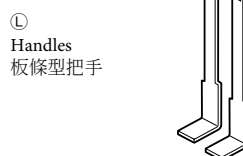
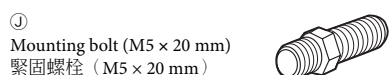
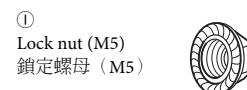
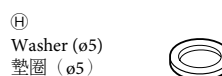
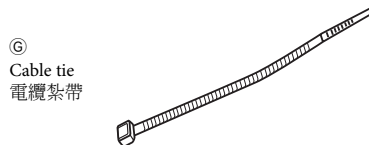
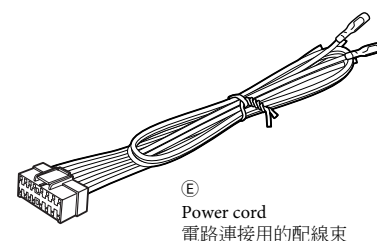
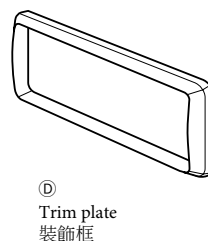
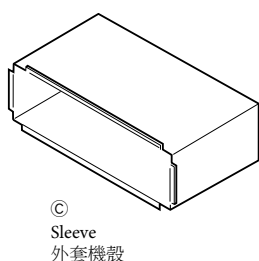
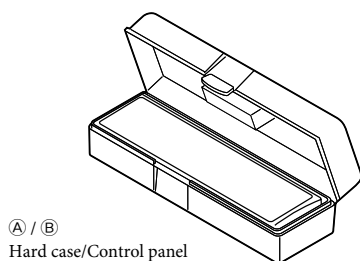

INSTALLATION (IN-DASH MOUNTING)

The following illustration shows a typical installation. If you have any questions or require information regarding installation kits, consult your JVC car audio dealer or a company supplying kits.

- If you are not sure how to install this unit correctly, have it installed by a qualified technician.

安裝（裝設、固定在儀表板內）

下面的圖解表示了典型的安裝程序。如果您有問題，或需要有關配套元件的資料，請向 JVC 汽車音響分銷商或配套元件供應公司詢問。

- 如果您不能確定如何正確地安裝本機，應請合格的技術人員來安裝。

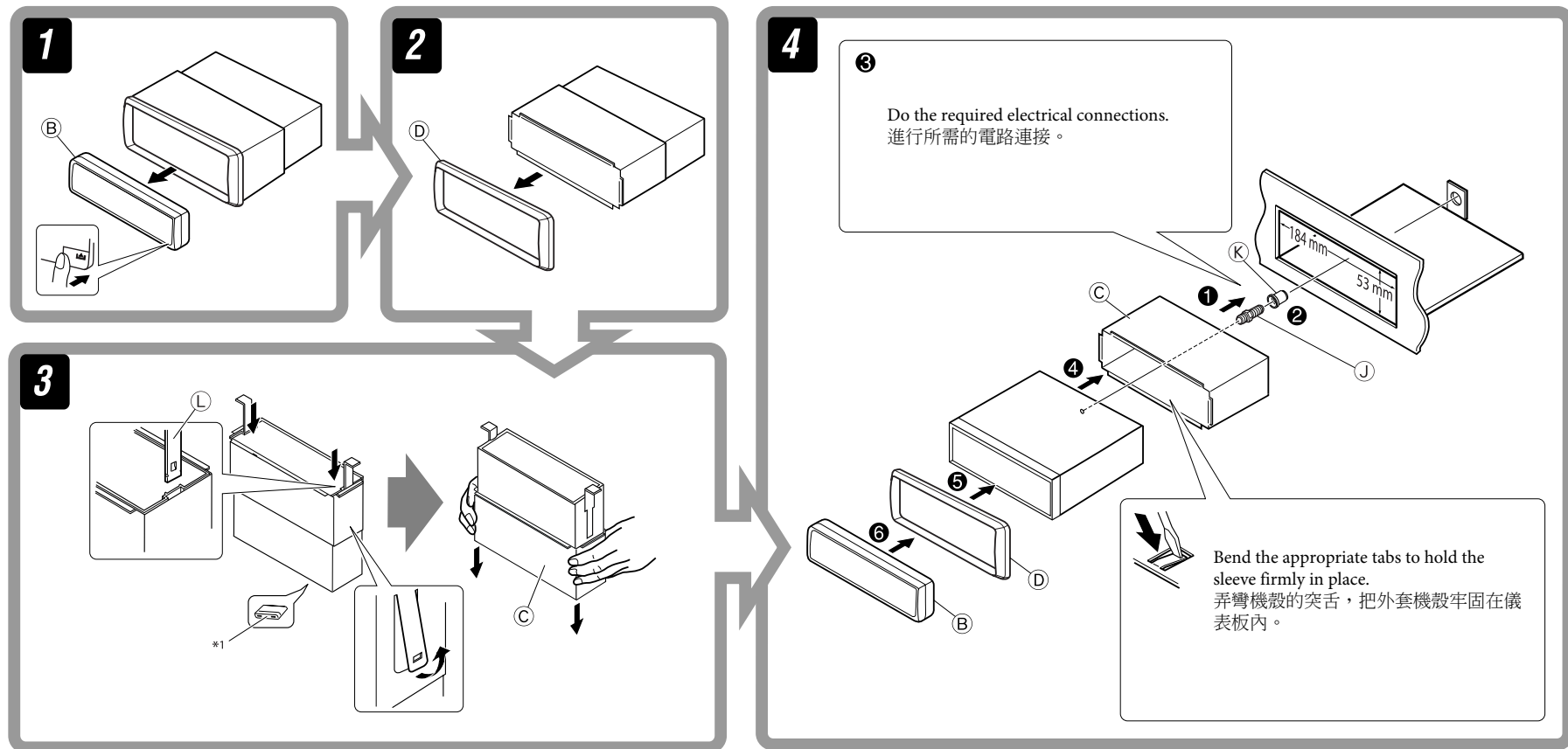

Removing the unit

Before removing the unit, release the rear section.

拆卸本機

在拆卸本機前，應將本機後部的固定和連接部分鬆開。

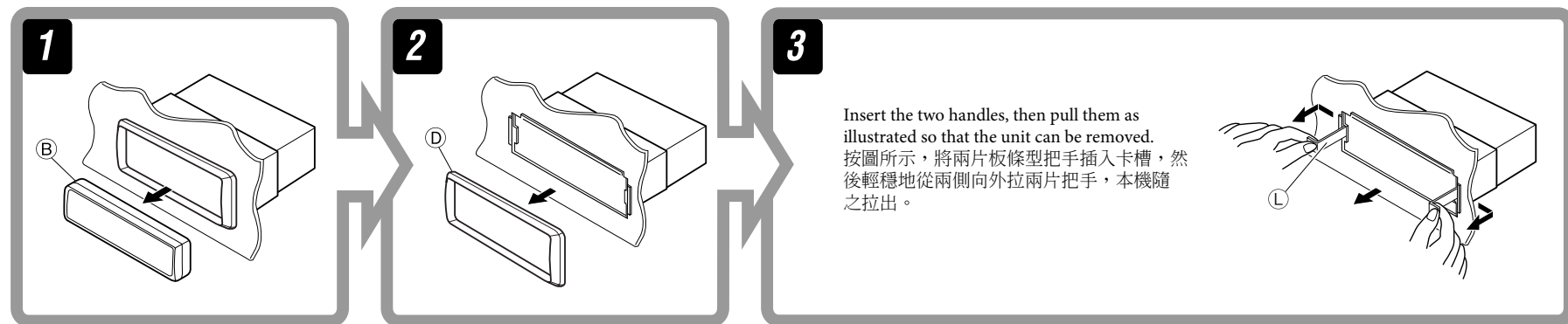

When using the optional stay / 若選用支撐架

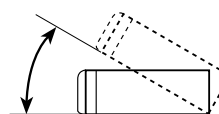
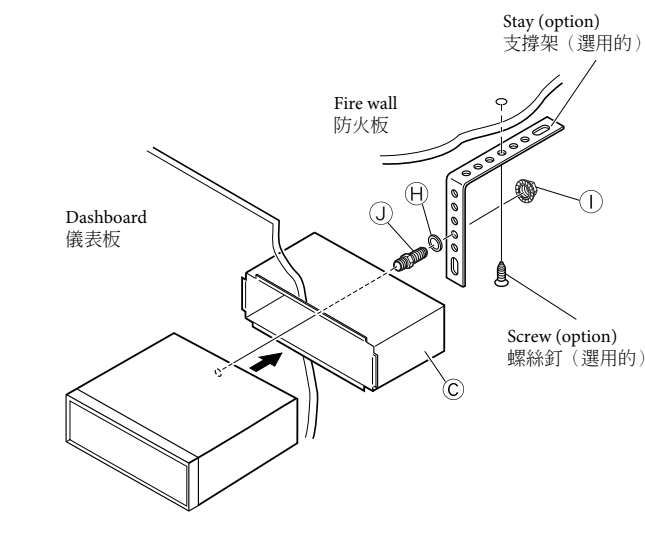

Install the unit at an angle of less than 30°. 將本機安裝在少於 30° 的角度。

When installing the unit without using the sleeve / 若不使用外套機殼安裝本機

In a Toyota car for example, first remove the car radio and install the unit in its place. 以豐田牌 (TOYOTA) 汽車為例：首先取出汽車收音機，然後將本機裝入其空出的位置。

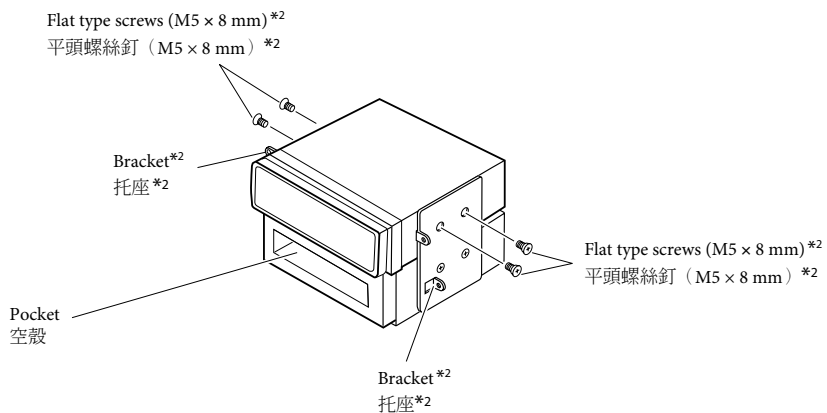

Note
注意

: When installing the unit on the mounting bracket, make sure to use the 8 mm -long screws. If longer screws are used, they could damage the unit.
: 把本機安裝在托座上時，務必使用 8 mm 長的螺絲釘。如使用過長的螺絲釘，會損壞本機。

*1 When you stand the unit, be careful not to damage the fuse on the rear.
*2 Not supplied for this unit.

*1 您豎起本機時，小心不要損壞底部的保險絲。
*2 不隨本機提供。

ELECTRICAL CONNECTIONS

電路連接

A Typical connections / 典型的接線方法

Before connecting: Check the wiring in the vehicle carefully. Incorrect connection may cause serious damage to this unit.
The leads of the power cord and those of the connector from the car body may be different in color.

接線前：仔細檢查汽車內的線路。不正確的接線會導致本機嚴重損壞。
電源線的引線和車身的連接器引線在顏色上可能有所不同。

- 1 Connect the colored leads of the power cord in the order specified in the illustration below.
- 2 Connect the antenna cord.
- 3 Finally connect the wiring harness to the unit.

- 1 依照下圖所示之次序連接電源線的顏色導線。
- 2 將天線的電線連接起來。
- 3 最後，把配線束的插頭插在本機上。

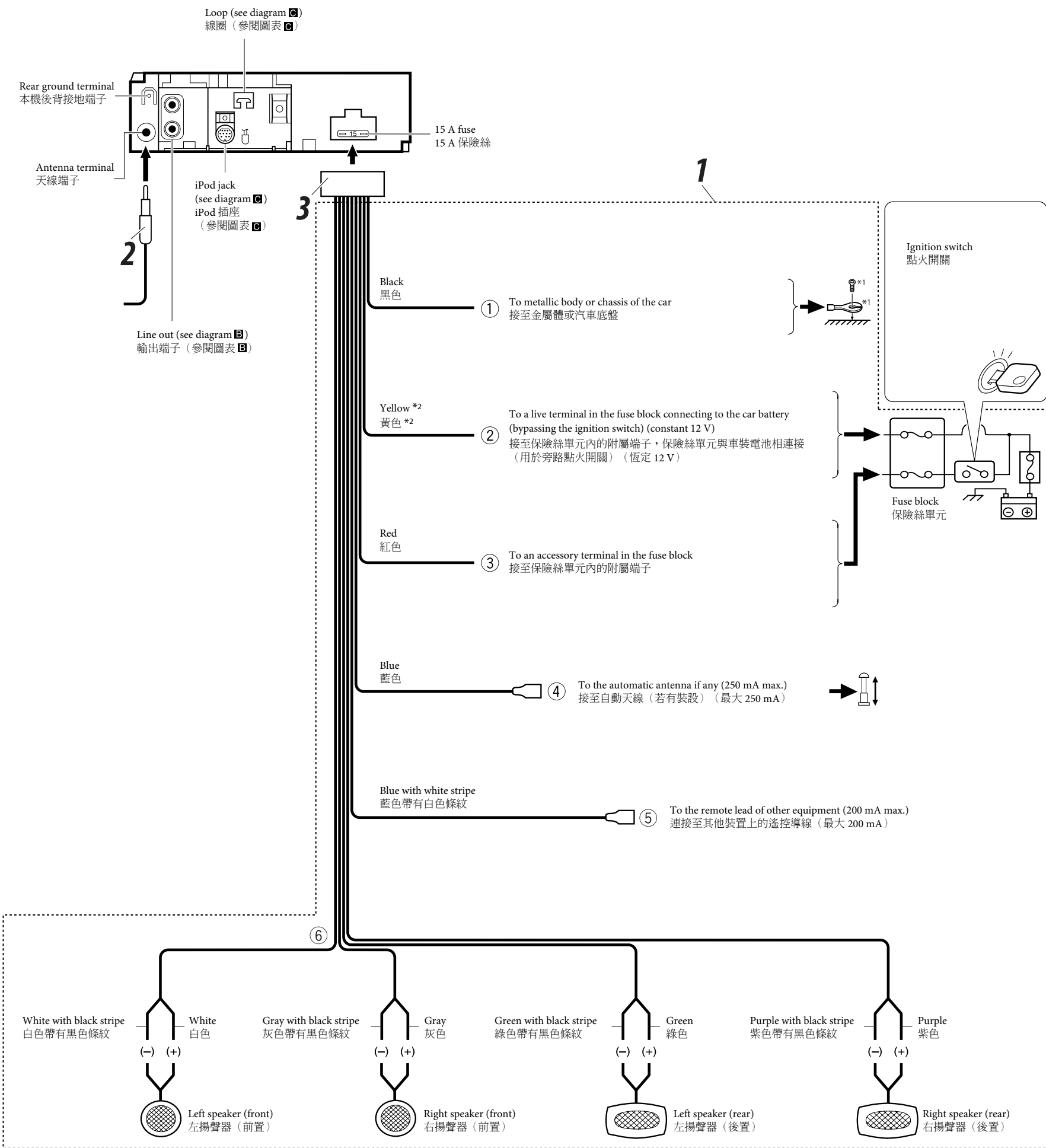

*1 Not supplied for this unit.

*2 Before checking the operation of this unit prior to installation, this lead must be connected, otherwise power cannot be turned on.

*1 不隨本機提供。

*2 本機未安裝時，進行工作狀況檢查之前，必須把這導線接上，否則不能開啟電源。

B Connecting the external amplifier or subwoofer / 連接至外部功率放大器或超重低音揚聲器

You can connect amplifier to upgrade your car stereo system.

- Connect the remote lead (blue with white stripe) to the remote lead of the other equipment so that it can be controlled through this unit.
- **Disconnect the speakers from this unit, connect them to the amplifier. Leave the speaker leads of this unit unused.**

您可以連接功率放大器以提昇專車的音響系統。

- 將遙控導線（藍色帶有白色條紋）和其他裝置上的遙控導線連接起來，以便可以通過本機進行遙控。
- 將揚聲器和本機斷開，再接上功率放大器。將本機的揚聲器接線放置不用。

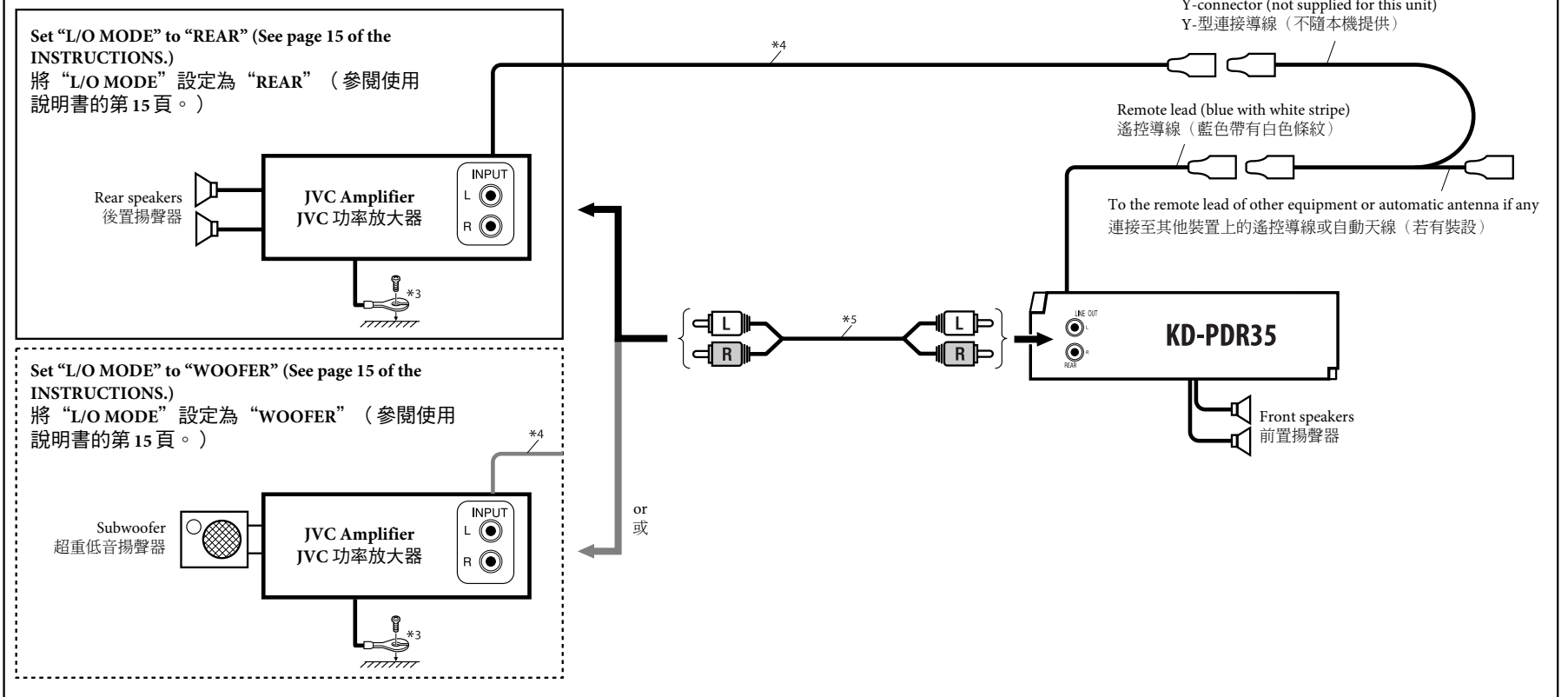

C Connecting an Apple iPod / 連接 Apple iPod

You can connect an iPod to this unit using the supplied connection cable for iPod.

- 1 Insert the supplied cable tie across the loop.
- 2 Press in the head of the connection cable for iPod until you hear a clicking sound.
- 3 Fasten the connection cable using the cable tie to firmly hold the connection cable in place.

您可以使用附帶的 iPod 連接電纜將 iPod 和本機連接起來。

- 1 將附帶的電纜紮帶系在線圈上。
- 2 按住 iPod 連接電纜的頭部直至您聽到一聲卡嗒聲。
- 3 使用電纜紮帶來固定 iPod 連接電纜的位置。

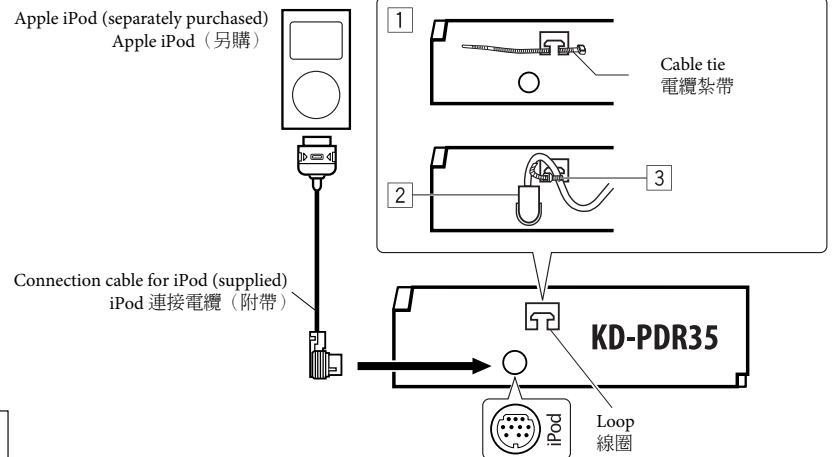

iPod is a trademark of Apple Computer, Inc., registered in the U.S. and other countries.
iPod 是 Apple Computer, Inc. (蘋果電腦公司) 在美國及其他國家註冊的商標。

*3 Firmly attach the ground wire to the metallic body or to the chassis of the car—to the place uncoated with paint (if coated with paint, remove the paint before attaching the wire). Failure to do so may cause damage to the unit.

*4 Remote lead

*5 Signal cord (not supplied for this unit).

*3 將地線與金屬車體或者汽車底盤緊密連接，連接處應該沒有被油漆覆蓋（如果已塗上油漆，在連接電線前，將油漆刮去）。如果不這樣做，可能會損壞本機。

*4 遙控導線

*5 信號電纜（不隨本機提供）。

TROUBLESHOOTING

• The fuse blows.

* Are the red and black leads connected correctly?

• Power cannot be turned on.

* Is the yellow lead connected?

• No sound from the speakers.

* Is the speaker output lead short-circuited?

• Sound is distorted.

* Is the speaker output lead grounded?

* Are the "-" terminals of L and R speakers grounded in common?

• Noise interfere with sounds.

* Is the rear ground terminal connected to the car's chassis using shorter and thicker cords?

• This unit becomes hot.

* Is the speaker output lead grounded?

* Are the "-" terminals of L and R speakers grounded in common?

• This unit does not work at all.

* Have you reset your unit?

故障排除

• 保險絲燒斷。

* 檢查紅色導線接頭和黑色導線接頭是否接觸正確？

• 電源不能接通。

* 檢查黃色導線接頭是否接上？

• 揚聲器沒有聲音。

* 檢查揚聲器輸出導線接頭是否短路？

• 聲音失真。

* 檢查揚聲器輸出端子是否接地？

* 檢查揚聲器的左 (L)、右 (R) 端子的負極 (-) 是否共同接地？

• 噪音干擾音響。

* 後接地端子與車身是否使用較短和較厚的電線連接？

• 本機發熱。

* 檢查揚聲器輸出端子是否接地？

* 檢查揚聲器的左 (L)、右 (R) 端子的負極 (-) 是否共同接地？

• 本機完全不能操作。

* 您是否已經重設您的機組？